



INDUSTRIAL SHIELDS

PLC ARDUINO LoRa ARDBOX 20 I/Os FAMILY HF PLUS MODBUS

PLC ARDUINO LoRa ARDBOX 20 I/Os

FAMILY HF

PLUS



PLC Arduino LoRa ARDBOX 20 I/Os Family HF PLUS User Guide

Revised July 2024

This user guide is for version PLC Arduino LoRa ARDBOX 20 I/Os Family HF PLUS with Reference name 015001001200 or 015001001300.

Preface

This User Guide has been implemented by Boot & Work, S.L. working under the name Industrial Shields.

Purpose of the manual

The information contained in this manual can be used as a reference to operating, to functions, and to the technical data of the signal modules, power supply modules and interface modules.

Intended Audience

This User Guide is intended for the following audience:

- Persons in charge of introducing automation devices.
- Persons who design automation systems.
- Persons who install or connect automation devices.
- Persons who manage working automation installation.



Warnings:

- Unused pins should not be connected. Ignoring the directive may damage the controller.
- Improper use of this product may severely damage the controller.
- Refer to the controller's User Guide regarding wiring considerations.
- Before using this product, it is the responsibility of the user to read the product's User Guide and all accompanying documentation.
- Maintenance must be performed by qualified personnel familiarised with the construction, operation, and hazards involved with the control.
- Maintenance should be performed with the control out of operation and disconnected from all sources of power.
- Care should be taken when servicing electrostatic sensitive components. The manufacturer's recommendations for these components should be followed.

- The Ardbox Family PLCs are Open Type Controllers. It is required that you install the Ardbox PLC in a housing, cabinet, or electric control room. Entry to the housing, cabinet, or electric control room should be limited to authorised personnel. Failure to follow these installation requirements could result in severe personal injury and/or property damage. Always follow these requirements when installing Ardbox family PLCs.
- In case of installation or maintenance of the Ardbox please follow the instructions marked in the Installation and Maintenance section.
- Do not disconnect equipment when a flammable or combustible atmosphere is present. Disconnection of equipment when a flammable or combustible atmosphere is present may cause a fire or explosion which could result in death, serious injury and/or property damage.



Avertissements:

- Les broches non utilisées ne doivent pas être connectées. Ignorer la directive peut endommager le contrôleur.
- Une utilisation incorrecte de ce produit peut endommager gravement le contrôleur.
- Reportez-vous au Guide de l'utilisateur du contrôleur pour les considérations de câblage.
- Avant d'utiliser ce produit, il incombe à l'utilisateur de lire le Guide de l'utilisateur du produit et la documentation qui l'accompagne.
- La maintenance doit être effectuée par personnel qualifié familiarisé avec la fabrication, le fonctionnement et les dangers liés au contrôleur.
- La maintenance doit être effectuée avec l'équipement hors service et déconnectée de toutes les sources d'alimentation.
- Faites attention lors de l'entretien des composants sensibles à l'électricité statique. Les recommandations du fabricant pour ces composants doivent être suivies.
- Les automates de la famille Ardbox sont des contrôleurs de type ouvert. Il est nécessaire d'installer l'automate Ardbox dans un boîtier, une armoire ou une salle de contrôle électrique. L'accès au boîtier, à l'armoire ou à la salle de commande électrique doit être limité au personnel autorisé. Le non-respect de ces exigences d'installation peut entraîner des blessures graves et/ou des dommages matériels importants. Respectez toujours ces exigences lors de l'installation des automates de la famille Ardbox.
- En cas d'installation ou de maintenance du Ardbox, veuillez suivre les instructions indiquées dans la section Installation et Maintenance.
- Ne débranchez pas l'équipement en présence d'une atmosphère inflammable ou combustible. La déconnexion de l'équipement en présence d'une atmosphère inflammable ou combustible peut provoquer un incendie ou une explosion pouvant entraîner la mort, des blessures graves et/ou des dommages matériels.

Application Considerations and Warranty

Read and Understand this Manual

Please read and understand this manual before using the product. Please consult your comments or questions to Industrial Shields before using the product.

Application Consideration

THE PRODUCTS CONTAINED IN THIS DOCUMENT ARE NOT SAFETY RATED. THEY SHOULD NOT BE RELIED UPON AS A SAFETY COMPONENT OR PROTECTIVE DEVICE FOR ENSURING SAFETY OF PERSONS, AS THEY ARE NOT RATED OR DESIGNED FOR SUCH PURPOSES.

Please know and observe all prohibitions of use applicable to the products.

FOR AN APPLICATION INVOLVING SERIOUS RISK TO LIFE OR PROPERTY WITHOUT ENSURING THAT THE SYSTEM AS A WHOLE HAS BEEN DESIGNED TO ADDRESS THE RISKS, NEVER USE THE INDUSTRIAL SHIELDS PRODUCTS.

NEVER USE THE INDUSTRIAL SHIELDS PRODUCTS BEFORE THEY ARE PROPERLY RATED AND INSTALLED FOR THE INTENDED USE WITHIN THE OVERALL EQUIPMENT OR SYSTEM.

Industrial Shields shall not be responsible for conformity with any codes, regulations or standards that apply to the combination of products in the customer's application or use of the product.

The following are some examples of applications for which particular attention must be given. This is not intended to be an exhaustive list of all possible uses of the products, nor is it intended to imply that the uses may be suitable for the products:

- Systems, machines, and equipment that could present a risk to life or property.
- Nuclear energy control systems, combustion systems, railroad systems, aviation systems, medical equipment, amusement machines, vehicles, safety equipment, and installation subject to separate industry or government regulations.
- Outdoor use, uses involving potential chemical contamination or electrical interference, or conditions or uses not described in this document.

At the customer's request, INDUSTRIAL SHIELDS will provide applicable third party certification documents identifying ratings and limitations of use that apply to the products. This information by itself is not sufficient for a complete determination of the suitability of the products in combination with the system, machine, end product, or other application or use.

Intended use of Industrial Shields products

Consider the following:

Industrial Shields products should only be used for the cases of application foreseen in the catalogue and the associated technical documentation. If third-party products and components are used, they must have been recommended or approved by Industrial Shields.

The correct and safe operation of the products requires that your transport, storage, installation, assembly, operation and maintenance have been carried out in a correct manner. It must respect the permissible ambient conditions. You should also follow the indications and warnings that appear in the associated documentation.

The product / system dealt with in this documentation should only be handled or manipulated by qualified personnel for the task entrusted and observing what is indicated in the documentation corresponding to it, particularly the safety instructions and warnings included in it. Due to their training and experience, qualified personnel are in a position to recognize risks resulting from the handling or manipulation of such products / systems and to avoid possible hazards.

Disclaimers

Weights and Dimensions

Dimensions and weights are nominal and they are not used for manufacturing purposes, even when tolerances are shown.

Performance Data

The performance data given in this manual is provided as a guide for the user in determining suitability and does not constitute a warranty. It may represent the result of INDUSTRIAL SHIELDS's test conditions, and the users must correlate it to actual application requirements. Actual performance is subject to the INDUSTRIAL SHIELDS Warranty and Limitations of Liability.

Errors and Omissions

The information in this document has been carefully checked and is believed to be accurate; however, no responsibility is assumed for clerical, typographical, or proofreading errors, or omissions.

Residual Risks

The control and drive components of an Industrial Shields PLC are approved for industrial and commercial use in industrial line supplies. Their use in public line supplies requires a different configuration and/or additional measures. These components may only be operated in closed housings or in higher-level control cabinets with protective covers that are closed, and when all of the protective devices are used. These components may only be handled by qualified and trained technical personnel who are knowledgeable and observe all of the safety information and instructions on the components and in the associated technical user documentation. When carrying out a risk assessment of a machine in accordance with the EU Machinery Directive, the machine manufacturer must consider the following residual risks associated with the control and drive components of a PDS.

1. Unintentional movements of driven machine components during commissioning, operation, maintenance, and repairs caused by, for example: – Hardware defects and/or software errors in the sensors, controllers, actuators, and connection technology – Response times of the controller and drive – Operating and/or ambient conditions not within the scope of the specification – Condensation / conductive contamination – Parameterization, programming, cabling, and installation errors – Use of radio devices / cellular phones in the immediate vicinity of the controller – External influences / damage.
2. Exceptional temperatures as well as emissions of noise, particles, or gas caused by, for example: – Component malfunctions – Software errors – Operating and/or ambient conditions not within the scope of the specification – External influences / damage.
3. Hazardous shock voltages caused by, for example: – Component malfunctions – Influence of electrostatic charging – Induction of voltages in moving motors – Operating and/or ambient conditions not within the scope of the specification – Condensation / conductive contamination – External influences / damage
4. Electrical, magnetic and electromagnetic fields generated in operation that can pose a risk to people with a pacemaker, implants or metal replacement joints, etc. if they are too close.
5. Release of environmental pollutants or emissions as a result of improper operation of the system and/or failure to dispose of components safely and correctly.

Warranty and Limitations of Liability

Warranty

Industrial Shields's exclusive warranty is that the products are free from defects in materials and workmanship for a period of one year (or other period if specified) from date of sale by Industrial Shields.

INDUSTRIAL SHIELDS MAKES NO REPRESENTATION OR WARRANTY, EXPRESSED OR IMPLIED, REGARDING MERCHANTABILITY, NON-INFRINGEMENT, OR FITNESS FOR PARTICULAR PURPOSE OF THE PRODUCTS. ANY BUYER OR USER ACKNOWLEDGES THAT THE BUYER OR USER ALONE HAS DETERMINED THAT THE PRODUCTS WILL SUITABLY MEET THE REQUIREMENTS OF THEIR INTENDED USE. INDUSTRIAL SHIELDS DISCLAIMS ALL OTHER WARRANTIES, EXPRESS OR IMPLIED

Limitations of Liability

INDUSTRIAL SHIELDS SHALL NOT BE RESPONSIBLE FOR SPECIAL, INDIRECT, OR CONSEQUENTIAL DAMAGES, LOSS OF PROFITS OR COMERCIAL LOSS IN ANY WAY CONNECTED WITH THE PRODUCTS, WHETHER SUCH CLAIM IS BASED ON CONTRACT, WARRANTY, NEGLIGENCE, OR STRICT LIABILITY.

IN NO EVENT SHALL INDUSTRIAL SHIELDS BE RESPONSIBLE FOR WARRANTY, REPAIR OR OTHER CLAIMS REGARDING THE PRODUCTS UNLESS INDUSTRIAL SHIELDS'S ANALYSIS CONFIRMS THAT THE PRODUCTS WERE PROPERLY HANDLED, STORED, INSTALLED, AND MAINTAINED AND NOT SUBJECT TO CONTAMINATION, ABUSE, MISUSE, OR INAPPROPRIATE MODIFICATION OR REPAIR.

Table of Contents

1. LoRa Ardbox Family HF: General Features.....	11
2. Technical Specifications.....	12
2.1 General Specifications.....	12
2.2 Performance Specification.....	12
2.3 Symbology.....	13
3. Precautions.....	14
3.1 Arduino Board.....	14
3.2 Intended Audience.....	14
3.3 General Precautions.....	14
4. Software interface.....	15
5. How to connect PLC Arduino to PC.....	18
6. How to connect PLC to power supply.....	19
7. Ardbox LoRa pinout.....	20
8. Ardbox LoRa Family I/O serigraphy.....	21
8.1 015001001200 Zone Connections.....	21
8.2 015001001300 Relay Zone Connections.....	23
9. Switch configuration.....	25
9.1 015001001200 Analog Model General Switches Configuration.....	25
9.2 015001001300 Relay Model General Switches Configuration.....	27
9.3 015001001200 Analog RS-232 and RS-485 Switch Configuration.....	28
9.4 015001001300 Relay RS-232 and RS-485 Switch Configuration.....	29
9.5 015001001200 Analog LoRa Switch Configuration.....	30
9.6 015001001300 Relay LoRa Switch Configuration.....	30
10. Jumper Configuration.....	31
10.1 015001001200 Analog General Jumper Configuration.....	31
10.2 015001001300 Relay General Jumper Configuration.....	32
11. Hardware Serial RS-232 & RS-485 Configuration.....	33
11.1 015001001200 Analog Hardware Serial RS-485.....	33
11.2 015001001200 Analog Hardware Serial RS-232.....	34
11.3 015001001300 Relay Hardware Serial RS-485.....	35
11.4 015001001300 Relay Hardware Serial RS-232.....	36
12. Ardbox - Arduino I/Os 5V pins.....	37
12.1 SPI - MISO / MOSI / SCK.....	37
13. LoRa Programming Examples.....	37
13.1 Introduction to LoRa.....	37
13.2 How to work with LoRaWAN.....	37
14. Digital inputs threshold detection.....	38



15. I/O technical details.....	38
16. Typical Connections.....	41
17. Connector details.....	45
18. ARDBOX Family Dimensions.....	46
19. Installation and Maintenance.....	47
20. Revision Table.....	50

1. LoRa Ardbox Family HF: General Features

COMPACT PLC ARDUINO LoRa ARDBOX 20I/Os Family LOG HF PLUS		
Input Voltage	12 to 24Vdc ---	Fuse protection (2.5A) Polarity protection
Input rated voltage	24Vdc ---	
Rated Power	30 W	
I Max.	1.5A	
Size	100x45x115	
Clock Speed	16MHz	
Flash Memory	32KB of which 4KB are used by bootloader	
SRAM	2.5KB	
EEPROM	1KB	
Communications	SPI -- USB -- RS232 -- RS485	RS485
An/Dig Input 10bit (0-10Vcc)	0 to 10Vdc Input Impedance: 39K Separated PCB ground Rated Voltage: 10Vdc 5 to 24Vdc I min: 2 to 12mA Galvanic Isolation Rated Voltage: 24 Vdc ---	*Check Section 14 for digital inputs threshold detection
* Interrupt isolated Input HS (24Vcc)	5 to 24Vdc I min: 2 to 12mA Galvanic Isolation Rated Voltage: 24Vdc	5 to 24Vdc I min: 3/6mA Separated PCB ground
Analog Output 8bit (0-10Vcc)	0 to 10Vdc I max: 20mA Separated PCB ground Rated Voltage: 10Vdc ---	
Digital Isolated Output (24Vcc)	5 to 24Vdc I max: 70mA Galvanic Isolation Diode Protected for Relay Rated Voltage: 24Vdc ---	I _{max} 24Vdc: 410mA
Digital Isolated Output Relay	30Vdc / 250Vac Galvanic Isolation Diode protected for Relay ---	I _{max} : 3A (30Vdc) I _{max} : 5A (250Vac)
PWM Isolated Output 8bit (24Vcc)	5 to 24Vdc I max: 70mA Galvanic Isolation Diode Protected for Relay Rated Voltage: 24Vdc ---	PWM Isolated Output 8bit (24Vcc)
Expandability	RS232 – RS485 – TTL	
Reference	015001001200 015001001300	Analog Relay

2. Technical Specifications

2.1 General Specifications









Power supply voltage	DC power supply	12 to 24Vdc 
Operating voltage range	DC power supply	11.4 to 25.4Vdc 
Power consumption	DC power supply	30W max.
External power supply	Power supply voltage	24Vdc 
	Power supply output capacity	700mA
Insulation resistance		20MΩ min. at 500Vdc between the AC terminals and the protective ground terminal.
Dielectric strength		2.300Vac at 50/ 60 Hz for one minute with a leakage current of 10mA max. Between all the external AC terminals and the protective earth terminal.
Shock resistance		80m/s ² in the X, Y and Z direction 2 times each.
Ambient temperature (operating)		0° to 60°C
Ambient humidity (operating)		10% to 90% (no condensation)
Ambient environment (operating)		With no corrosive gas
Ambient temperature (storage)		-20° to 60°C
Power supply holding time		2ms min.
Weight		350g max.

2.2 Performance Specification

Arduino Board	ARDUINO LEONARDO
Control method	Stored program method
I/O control method	Combination of the cyclic scan and immediate refresh processing methods.
Programming language	Arduino IDE. Based on wiring (Wiring is an Open Source electronics platform composed of a programming language. "similar to the C"). http://arduino.cc/en/Tutorial/HomePage
Microcontroller	ATmega32u4
Flash Memory	32KB of which 4KB are used by bootloader
Program capacity (SRAM)	2.5KB
EEPROM	1KB
Clock Speed	16MHz

2.3 Symbology

Table that includes all the symbology that is used in the serigraph of the LoRa Ardbox Family HF+:

Symbol	Standard No. / Standard Title	Standard Reference No. / Symbol Title	Symbol Meaning
	IEC 60417 / Graphical symbols for use on equipment	5031 / Direct Current	Indicates that the equipment is suitable for direct current only; to identify relevant terminals
	IEC 60417 / Graphical symbols for use on equipment	5032 / Alternating Current	Indicates that the equipment is suitable for alternating current only; to identify relevant terminals
	IEC 60417 / Graphical symbols for use on equipment	5130 / Pulse General	To identify the control by which a pulse is started.
	IEC 60417 / Graphical symbols for use on equipment	5017 / Earth, Ground	To identify an earth (ground) terminal in cases where neither the symbol 5018 nor 5019 is explicitly required.
	IEC 60417 / Graphical symbols for use on equipment	5115 / Signal lamp	To identify the switch by means of which the signal lamp(s) is (are) switched on or off.
	Medical Devices Directive 93/42/EEC	CE Marking	CE marking indicates that a product complies with applicable European Union regulations
	ISO 7000/ Graphical symbols for use on equipment	0434B / Warning symbol	Indicates a potentially hazardous situation which, if not avoided, could result in death or serious injury
	ISO 7000/ Graphical symbols for use on equipment	5036 / Dangerous Voltage	To indicate hazards arising from dangerous voltages

3. Precautions

Read this manual before attempting to use the ARDBOX 20 I/Os Family HF LoRa PLUS and follow its descriptions for reference during operation.

3.1 Arduino Board

The ARDBOX 20 I/Os Family HF LoRa PLUS PLCs include Arduino Leonardo Board as controller.

3.2 Intended Audience

This manual is intended for technicians, which must have knowledge on electrical systems.

3.3 General Precautions

The user must operate Ardbox according to the performance specifications described in this manual.

Before using ARDBOX 20 I/Os Family HF LoRa PLUS under different conditions from what has been specified in this manual or integrating ARDBOX 20 I/Os Family HF LoRa PLUS to nuclear control systems, railroad systems, aviation systems, vehicles, combustion systems, medical equipment, amusement machines, safety equipment and other systems, machines, and equipment that may have a serious influence on lives and property if used improperly, consult your INDUSTRIAL SHIELDS representative. Ensure that the rating and performance characteristics of Ardbox are sufficient for the systems, machines, and equipment, and be sure to provide the systems, machines, and equipment double safety mechanisms. This manual provides information for programming and operating the Ardbox.

4. Software interface

Industrial Shields PLC are programmed using Arduino IDE, which is a software based on the C language. They can also be programmed directly using C, but it is much easier working with Arduino IDE, as it provides lots of useful libraries.

Industrial Shields provide a boards package for programming the PLCs, making it easier and friendlier. It includes various facilities such as not having to define the pins, etc.

In order to install Industrial Shields boards, these are the steps that must be followed.

Requirements:

Arduino IDE 1.8.15 or above (recommended: 1.8.19).

Steps:

1. Open Arduino IDE and go to: "File -> Preferences" located in the top left corner.

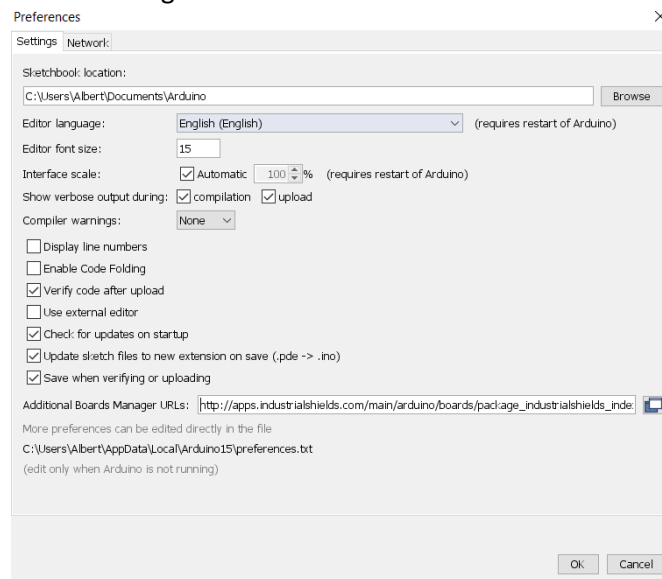

2. In Additional Boards URLs write the following:

http://apps.industrialshields.com/main/arduino/boards/package_industrialshields_index.json

3. Press OK to save the changes.
4. Go to: Tools -> Board: ... -> Boards Manager

5. Search for industrialshields.

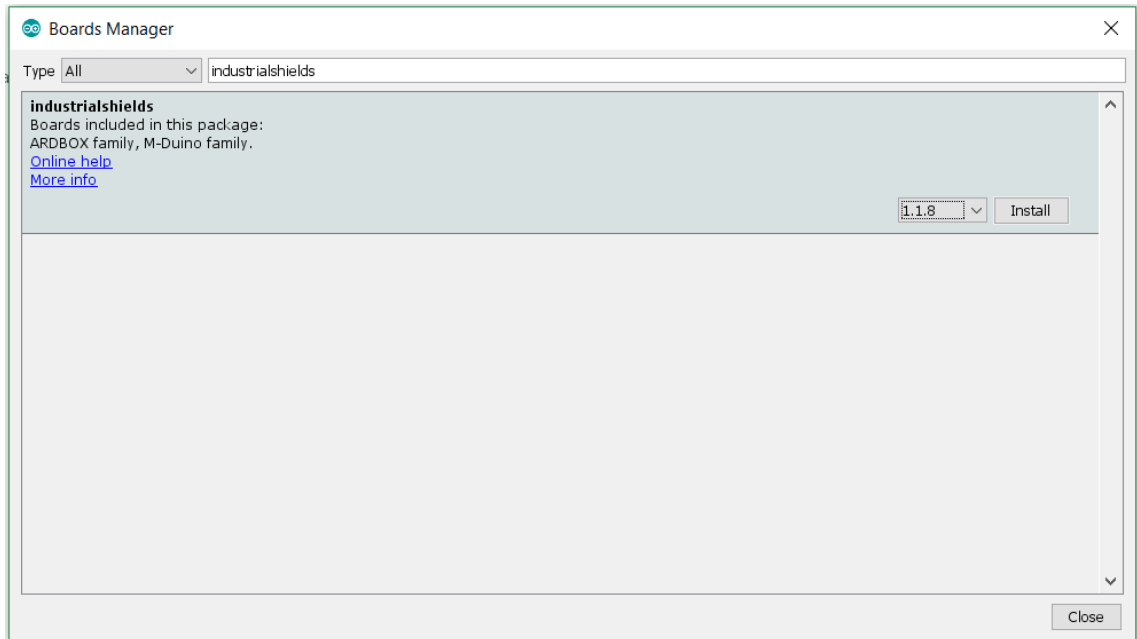

6. Click install (selecting the latest version).

Following this steps you will be able to use now the Industrial Shields Boards:

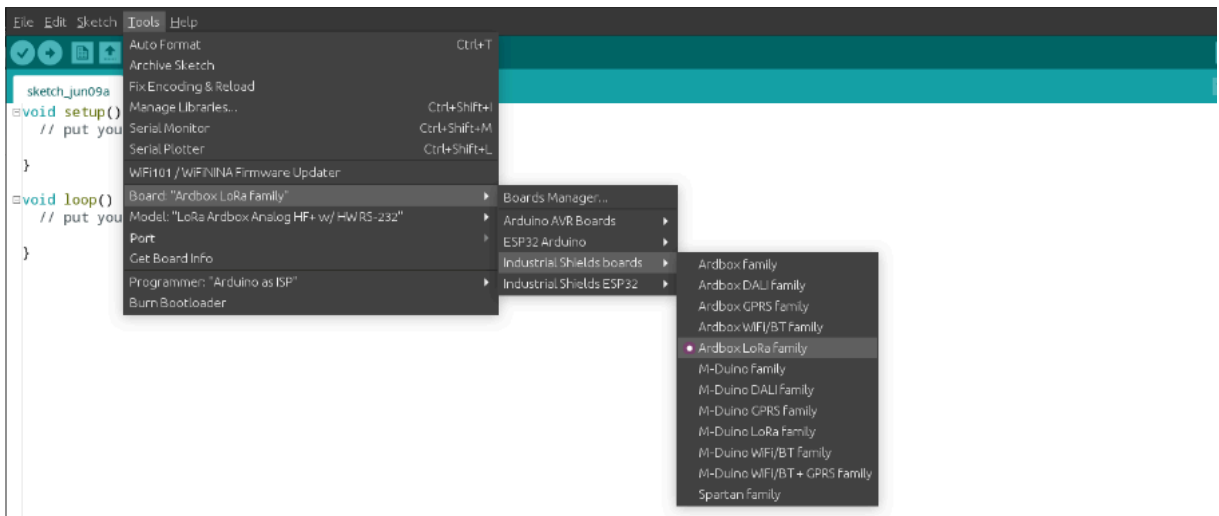

Once the Ardbox Family is selected, an extra option will appear on Tools:

- Select the correct Ardbox Family HF PLUS Board (Ardbox Analog HF+ w/HW RS-232 LoRa, Ardbox Analog HF+ w/HW RS-485 LoRa, Ardbox Relay HF+ w/HW RS-232 LoRa or Ardbox Relay HF+ w/HW RS-485 LoRa) depending on your jumpers & switch configuration.

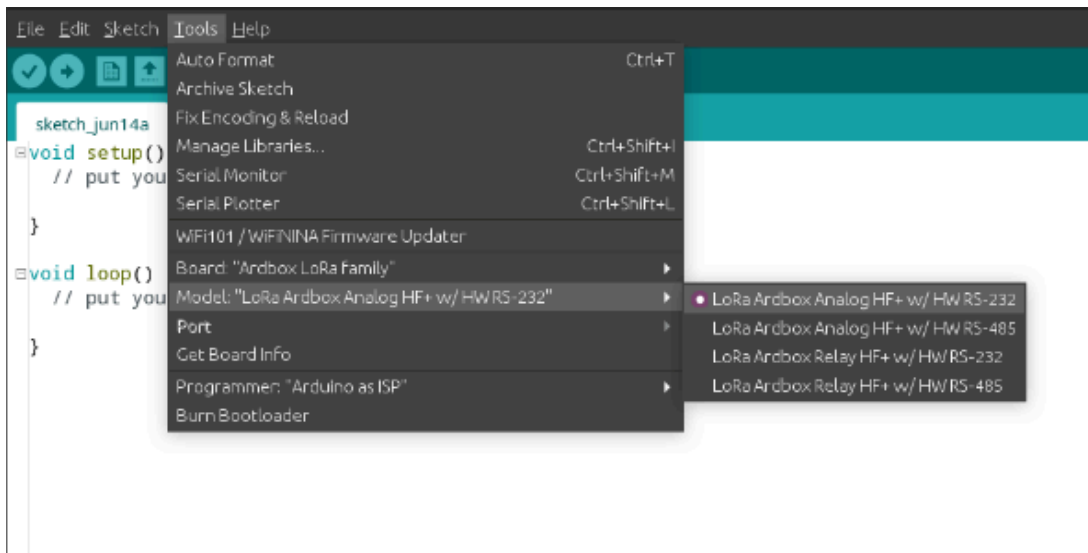

Also there are some examples of programming in File -> Examples -> Ardbox LoRa Family.

Furthermore there are some extra libraries that can be found in Industrial Shields GitHub:

<https://github.com/IndustrialShields/>

5. How to connect PLC Arduino to PC

- Connect USB port from PLC to PC.

NOTE:

Ardbox Family uses micro USB cable.



- Open Arduino IDE interface:
- Select Industrial Shields boards -> Ardbox LoRa Family
- Select the correct port.

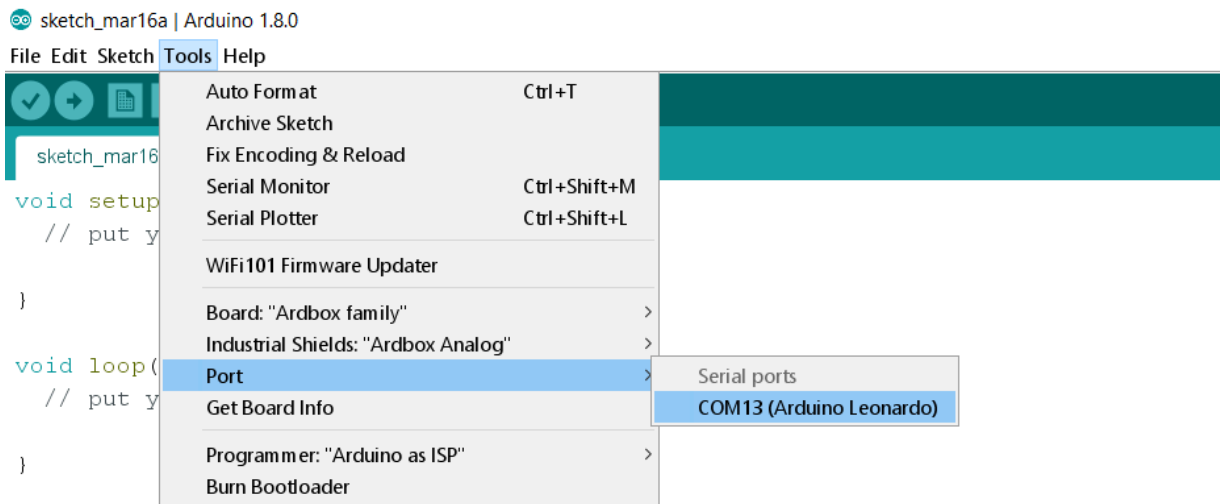

6. How to connect PLC to power supply

- Ardbox LoRa Family PLCs are 12-24Vdc supplied. **IMPORTANT: The polarity IS NOT REVERSIBLE!**
- Make sure that the live and GND connector of the power supply match the PLC.
- Make sure that the power supply mains output is not higher than 24Vdc.

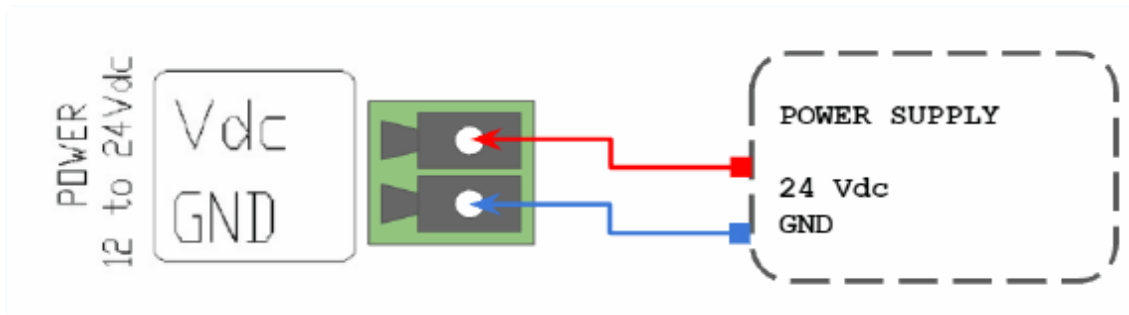

- Suggested power suppliers

Compact DIN rail power supply. Assembled on 35mm

DIN Rail:

-12Vdc / 24Vdc

-2.5A

-30W

Industrial Shields power supplies provide parallel operation, overvoltage protection, and overcurrent protection. There is a LED indicator for power status, the power supply is certified according to UL.



The standard, Part 1 of IEC 61010, sets the general safety requirements for the following types of electrical devices and their accessories, regardless of where use of the device is intended.

The equipment must be powered from an external power source in accordance with IEC 61010-1, whose output is MBTS and is limited in power according to section 9.4 of IEC 61010-1.

WARNING: Once the equipment is installed inside an electrical cabinet, the MTBS cables of the equipment must be separated from the dangerous voltage cables.

7. Ardbox LoRa pinout

		IOs Table				
Model	Reference	Analog Input	Digital Isolated Input	Digital Isolated Output	Digital/Analogic Output	Relay Output
ANALOG	015001001200	7	8	9	6	0
RELAY	015001001300	7	8	0	2	7

8. Ardbox LoRa Family I/O serigraphy

8.1 015001001200 Zone Connections

LEFT ZONE		
Ardbox Connector	Arduino Pin	Function
NC	-	Not Connected
A0.5 ¹	5	Analog Out
A0.4 ¹	6	Analog Out
A0.3 ¹	9	Analog Out
A0.2 ¹	10	Analog Out
A0.1 ¹	11	Analog Out
A0.0 ¹	13	Analog Out
Q0.9 ¹	1	Digital Output
Q0.8 ²	0	Digital Output
Q0.7	7	Digital Output
NC	-	Not Connected
Q0.5	5	PWM/digital Output
Q0.4	6	PWM/digital Output
Q0.3	9	PWM/digital Output
Q0.2	10	PWM/digital Output
Q0.1	11	PWM/digital Output
Q0.0	13	PWM/digital Output
GNDCOM	-	GND
24VCOM	-	Power Supply

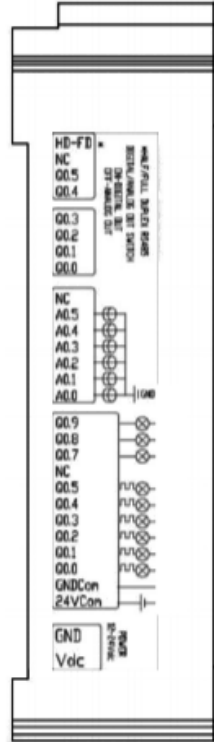

LEFT ZONE

Switch config*

(see section 8 for Communications configuration. Enabling Communications disables some I/Os)

Analog Outputs pins

Digital Outputs pins

Power supply connectors (24Vdc – GND)

¹ See [section 9](#) to enable these connections

RIGHT ZONE		
Ardbox Connector	Arduino Pin RS232 HS*	Function
A+ ^{2,3}	-	RS485(A)
B- ^{3,4}	-	RS485(B)
Y+ ^{3,4}	-	RS485(Y)
Z- ^{3,4}	-	RS485(Z)
NC	-	Not Connected
NC	-	Not Connected
TX-PIN4	4	-
RX-PIN8	8	-
GND	-	Ground
5V	-	5Vout DC
RESET	-	RESET
SCK	-	SPI-SCK
MOSI	-	SPI-MOSI
MISO	-	SPI-MISO
I0.9	18	Analog/Digital Input
I0.8	19	Analog/Digital Input
I0.7	20	Analog/Digital Input
I0.6	21	Analog/Digital Input
I0.5	22	Analog/Digital Input
NC	-	Not Connected
I0.3 ³	26	Analog/Digital Input
I0.2 ³	24	Analog/Digital Input
I0.1	29	Digital Input
NC	-	Not Connected

HS*: Hardware Serial
SS*: Software Serial

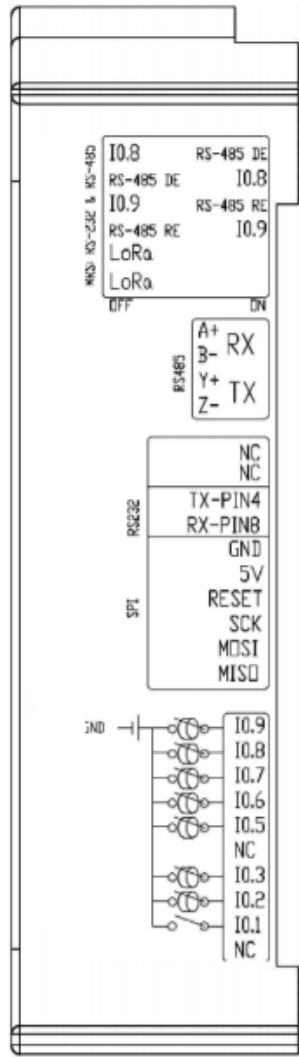

RIGHT ZONE

Switch config*
(see section 8 for Communications configuration. Enabling Communications disables some I/Os)

Communication pins

Digital/Analog

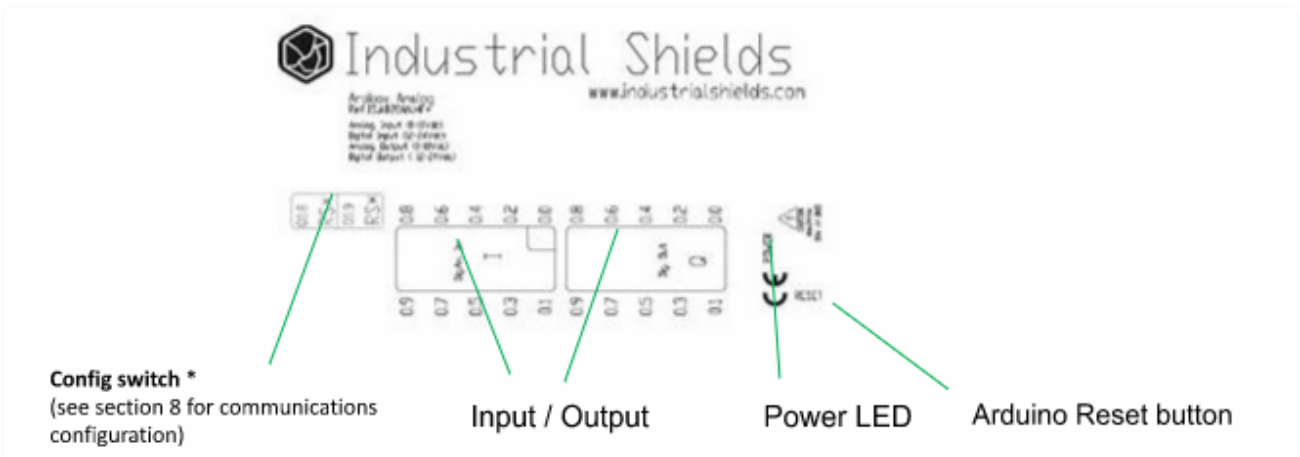

² See [section 8](#) to enable these connections
³ See [section 9](#) to enable these connections

8.2 015001001300 Relay Zone Connections

Left Zone		
Ardbox Connector	Arduino Pin	Function
MISO	14	SPI-MISO
MOSI	16	SPI-MOSI
SCK	15	SPI-SCK
RESET	-	SPI-RESET
5Vdc	-	5V Output
GND	-	GND
RX-RS-232 ^{4, 5}	8	Serial/RS232
TX-RS-232 ^{5, 6}	4	Serial/RS232
NC	-	Not Connected
NC	-	Not Connected
R1	10	Relay 1 Out
R2	9	Relay 2 Out
R3	6	Relay 3 Out
GND	-	GND
24V	-	-

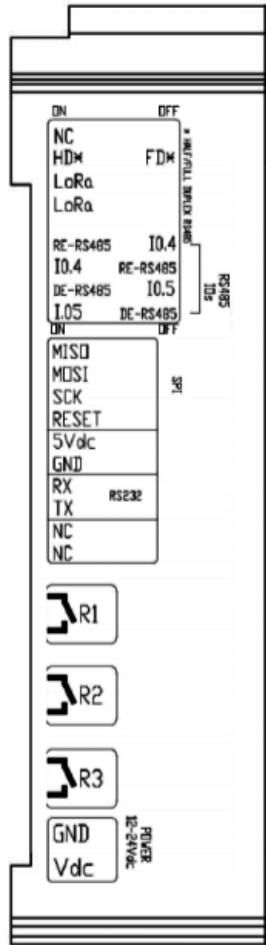

LEFT ZONE

Switch config*

(see section 8 for Communications configuration. Enabling Communications disables some I/Os)

Communication pins

Relay Outputs

Power supply connectors (24Vdc – GND)

HS*: Hardware Serial

SS*: Software Serial

⁴ See [section 8](#) to enable these connections

⁵ See [section 9](#) to enable these connections

Right Zone		
Ardbox Connector	Arduino Pin	Function
B-	-	RS485
A+	-	RS485
Z-/A0.1	-	RS485/ Digital Output
Y+/A0.0	-	RS485/ Digital Output
R4	5	Relay 4 Out
NC	-	Not Connected
NC	-	Not Connected
I0.8	22	Analog/ Digital Input
I0.7	21	Analog/ Digital Input
I0.6	20	Analog/ Digital Input
I0.5	19	Analog/ Digital Input
I0.4	18	Analog/ Digital Input
I0.3	8	Digital Optoisolated Input
I0.2	4	Digital Optoisolated Input
I0.1	12	Digital Input
NC	-	Not Connected
R6	7	Relay 6 Out
R7	0	Relay 7 Out
R8	1	Relay 8 Out

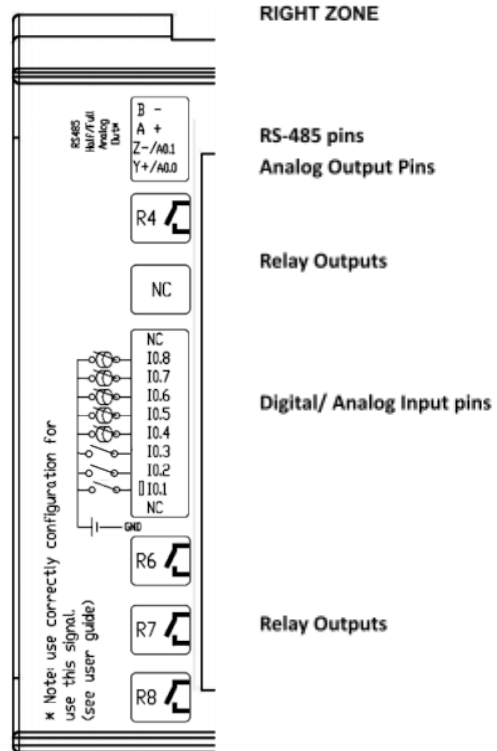

*Depending on the mode HD/FD the Y+/Z- Analog Output pins are enabled or disabled. See [section 9](#) to see the configurations.

9. Switch configuration

9.1 015001001200 Analog Model General Switches Configuration

LEFT ZONE SWITCH

Communications and inputs/outputs can not work simultaneously.

LEFT ZONE		
SWITCH	OFF	ON
I0.8 / RS-485 DE	I0.8	RS-485 DE
RS-485 DE / I0.8	RS-485 DE	I0.8
I0.9 / RS-485 RE	I0.9	RS-485 RE
RS-485 RE / I0.9	RS-485 RE	I0.9
LoRa / NC	LoRa	NC
LoRa / NC	LoRa	NC

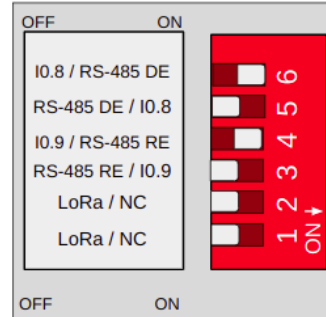

6. I0.8 / RS-485 DE – If this switch is ON the RS-485 DE is activated, otherwise the I0.8 will be activated.

5. RS-485 DE / I0.8 – If this switch is ON the I0.8 is activated, otherwise the RS-485 DE will be activated.

Note To work with RS-485 DE, switch number 6 at ON and number 5 at OFF.*

4. I0.9 / RS-485 RE – If this switch is ON the RS-485 RE is activated, otherwise the I0.9 will be activated.

3. RS-485 / I0.9 – If this switch is ON the I0.9 is activated, otherwise the RS-485 RE will be activated.

Note To work with RS-485 RE, switch number 4 at ON and number 3 at OFF.*

2. LoRa / NC – If this switch is ON the LoRa is deactivated, otherwise LoRa will be activated. Always in OFF mode as NC stands for not connected and Lora will not be enabled therefore.

1. LoRa / NC – If this switch is ON the LoRa is deactivated, otherwise LoRa will be activated. Always in OFF mode as NC stands for not connected and Lora will not be enabled therefore.

TOP ZONE SWITCH

TOP ZONE		
SWITCH	ON	OFF
Q0.8	Q0.8	RS*
RS*	RS*	Q0.8
Q0.9	Q0.9	RS*
RS*	RS*	Q0.9

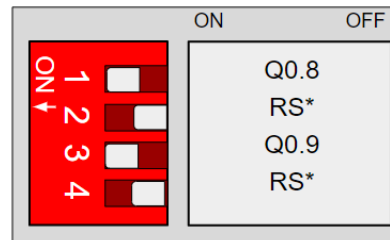

- Q0.8** - If this switch is ON the Q0.8 is activated, otherwise the RS* will be activated.
- RS*** - If this switch is ON the RS* is activated, otherwise the Q0.8 will be activated.
- Q0.9** - If this switch is ON the Q0.9 is activated, otherwise the RS* will be activated.
- RS*** - If this switch is ON the RS* is activated, otherwise the Q0.9 will be activated.

Note RS * can be RS-485 or RS-232 depending on the jumper configuration you have chosen. To work with RS*, switches number 1 and 3 at OFF and number 2 and 4 at ON.*

RIGHT ZONE SWITCH

RIGHT ZONE		
SWITCH	ON	OFF
HD / FD	Half Duplex	Full Duplex
NC	-	-
Q0.5	DIGITAL (Q0.5)	ANALOG (A0.5)
Q0.4	DIGITAL (Q0.4)	ANALOG (A0.4)
Q0.3	DIGITAL (Q0.3)	ANALOG (A0.3)
Q0.2	DIGITAL (Q0.2)	ANALOG (A0.2)
Q0.1	DIGITAL (Q0.1)	ANALOG (A0.1)
Q0.0	DIGITAL (Q0.0)	ANALOG (A0.0)

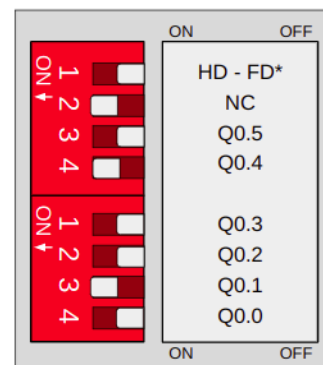

RIGHT ZONE.

1. HD/FD – Choosing between Half/Full Duplex for the RS485 communication. In order to use Full Duplex, it has to be considered the TOP ZONE and the JUMPER ZONE (see [section 9](#)).

2-8. Q0.X/A0.X – The right zone configures the outputs. If the switch is set to “ON” the Q0.X will have the behaviour of a digital output. If it is set to “OFF” it will be analog.

9.2 015001001300 Relay Model General Switches Configuration

LEFT ZONE SWITCH

Communications and inputs/outputs can not work simultaneously.

LEFT ZONE		
SWITCH	ON	OFF
NC	-	-
HD/FD*	Half Duplex	Full Duplex
NC / LoRa	NC	LoRa
NC / LoRa	NC	LoRa
RE-RS485 / I0.4	RE-RS485	I0.4
I0.4 / RE-RS485	I0.4	RE-RS485
DE-RS485 / I0.5	DE-RS485	I0.5
I0.5 / DE-RS485	I0.5	DE-RS485

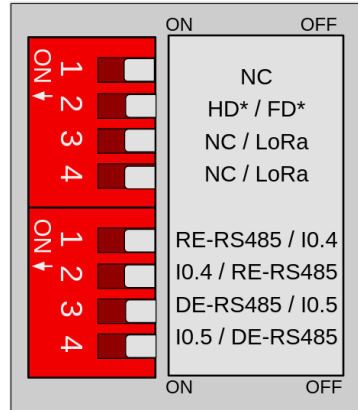

1. **NC** – Not Connected
2. **HD/FD*** – Choosing between Half/Full Duplex for the RS485 communication. In order to use Full Duplex, it has to be considered the TOP ZONE and the JUMPER ZONE (see [section 9](#)).
3. **LoRa / NC** – If this switch is ON the LoRa is deactivated, otherwise LoRa will be activated. Always in OFF mode as NC stands for not connected and Lora will not be enabled therefore.
4. **LoRa / NC** – If this switch is ON the LoRa is deactivated, otherwise LoRa will be activated. Always in OFF mode as NC stands for not connected and Lora will not be enabled therefore.

1. **RE-RS485 / I0.4** – If this switch is ON the RE-RS485 is activated, otherwise the I0.4 will be activated.
2. **I0.4 / RE-RS485** – If this switch is ON the I0.4 is activated, otherwise the RE-RS485 will be activated.

Note To work with RS-485 RE, switch number 1 at ON and number 2 at OFF.*

3. **DE-RS485 / I0.5** – If this switch is ON the DE-RS485 is activated, otherwise the I0.5 will be activated.
4. **I0.5 / DE-RS485** – If this switch is ON the I0.5 is activated, otherwise the DE-RS485 will be activated.

Note To work with RS-485 DE, switch number 3 at ON and number 4 at OFF.*

TOP ZONE SWITCH

TOP ZONE		
SWITCH	ON	OFF
RS*	RS*	R8
R8	R8	RS*
RS*	RS*	R7
R7	R7	RS*

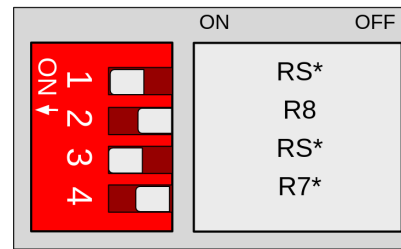

1. **RS*** - If this switch is ON the RS* is activated, otherwise the R8 will be activated.
2. **I0.2** - If this switch is ON the R8 is activated, otherwise the RS* will be activated.
3. **RS*** - If this switch is ON the RS* is activated, otherwise the R7 will be activated.
4. **I0.3** - If this switch is ON the R7 is activated, otherwise the RS* will be activated.

Note RS * can be RS-485 or RS-232 depending on the jumper configuration you have chosen. To work with RS*, switches number 1 and 3 at ON and number 2 and 4 at OFF.*

9.3 015001001200 Analog RS-232 and RS-485 Switch Configuration

ANALOG TOP ZONE	
SWITCH	MODE
Q0.8	OFF
RS*	ON
Q0.9	OFF
RS*	ON

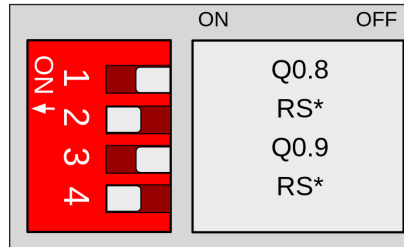

RS* TOP ZONE: In order to enable the RS* protocol the TOP ZONE must be configured as it is shown in the table.

Having this setup, the Q0.8 & Q0.9 are disabled.

1. **Q0.8** - If this switch is ON the Q0.8 is activated, otherwise the RS* will be activated.
2. **RS*** - If this switch is ON the RS* is activated, otherwise the Q0.8 will be activated.
3. **Q0.9** - If this switch is ON the Q0.9 is activated, otherwise the RS* will be activated.
4. **RS*** - If this switch is ON the RS* is activated, otherwise the Q0.9 will be activated.

ANALOG LEFT ZONE		
SWITCH	RS232 MODE	RS485 MODE
I0.8 / RS* DE	OFF	ON
RS* DE / I0.8	ON	OFF
I0.9 / RS* RE	OFF	ON
RS* RE / I0.9	ON	OFF
LoRa / NC	-	-
LoRa / NC	-	-

RS* LEFT ZONE: In order to enable the RS* communication protocol it is necessary that the switches of the left one are configured as it is shown in the table.

The ones marked with “-” mean that they do not affect the RS* communication protocol.

9.4 015001001300 Relay RS-232 and RS-485 Switch Configuration

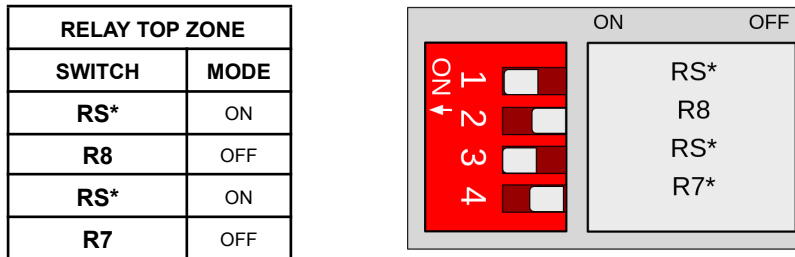

RS* TOP ZONE: In order to enable the RS* protocol the TOP ZONE must be configured as it is shown in the table.

Having this setup, the R7 & R8 are disabled.

1. **RS*** - If this switch is ON the RS* is activated, otherwise the R8 will be activated.
2. **R8** - If this switch is ON the R8 is activated. otherwise the RS* will be activated.
3. **RS*** - If this switch is ON the RS* is activated, otherwise the R7 will be activated.
4. **R7** - If this switch is ON the R7 is activated, otherwise the RS* will be activated.

RELAY LEFT ZONE		
SWITCH	RS232 MODE	RS485 MODE
NC	-	-
HD/FD	ON / OFF	ON / OFF
LoRa / NC	-	-
LoRa / NC	-	-
RE-RS485 / I0.4	OFF	ON
I0.4 / RE-RS485	ON	OFF
DE-RS485 / I0.5	OFF	ON
I0.5 / DE-RS485	ON	OFF

HD/FD: Choosing between Half Duplex or Full Duplex for the RS* communication. In order to use Full Duplex, it has to be considered the TOP ZONE and the JUMPER ZONE (see [section 9](#)).

RS* LEFT ZONE: In order to enable the RS* communication protocol it is necessary that the switches of the left zone are configured as it is shown in the table.

The ones marked with “-” mean that they do not affect the RS* communication protocol.

9.5 015001001200 Analog LoRa Switch Configuration

TOP ZONE		LEFT ZONE	
SWITCH	MODE	SWITCH	MODE
Q0.8	-	I0.8 / RS-485 DE	-
RS*	-	RS-485 DE / I0.8	-
Q0.9	-	I0.9 / RS-485 RE	-
RS*	-	RS-485 RE / I0.9	-
		LoRa / NC	OFF
		LoRa / NC	OFF

The ones marked with “-” mean that they do not affect the LoRa communication protocol.

9.6 015001001300 Relay LoRa Switch Configuration

TOP ZONE		LEFT ZONE	
SWITCH	MODE	SWITCH	MODE
RS*	-	NC	-
R8	-	HD / FD*	-
RS*	-	NC / LoRa	OFF
R7	-	NC / LoRa	OFF
		RE-RS485 / I04	-
		I0.4 / RE-RS485	-
		DE-RS485 / I0.5	-
		I0.5 / DE-RS485	-

The ones marked with “-” mean that they do not affect the LoRa communication protocol.

10. Jumper Configuration

10.1 015001001200 Analog General Jumper Configuration

JUMPER ZONE 1	
LEFT	RIGHT
RS-485	RS-485
D0	D1
RS-232	RS-232

This jumper makes the choice between connecting MAX232 to pins 0,1 of the Arduino Leonardo or with the MAX485. In order to use the RS-232 Hardware Serial protocol both RS-232 must be connected to the D1/D0. In order to use the RS-485 Hardware Serial protocol both RS-485 must be connected to the D1/D0.

JUMPER ZONE 2	
LEFT	RIGHT
Q0.9	Q0.8
D4	D8
RS-232 SS	RS-232 SS

This jumper zone makes the choice between connecting the inputs Q0.9, Q0.8 to pins 4 and 8 of the Arduino Leonardo respectively, or connect the RS-232 ports to activate the Software Serial RS-232. In order to use the inputs Q0.9, Q0.8 the jumper must be connected to the pins 4 and 8. So Q0.9 must be connected with D4 and Q0.8 must be connected to D8.

**The jumpers that are not connected to the middle jumpers MUST NOT be Connected anywhere.*

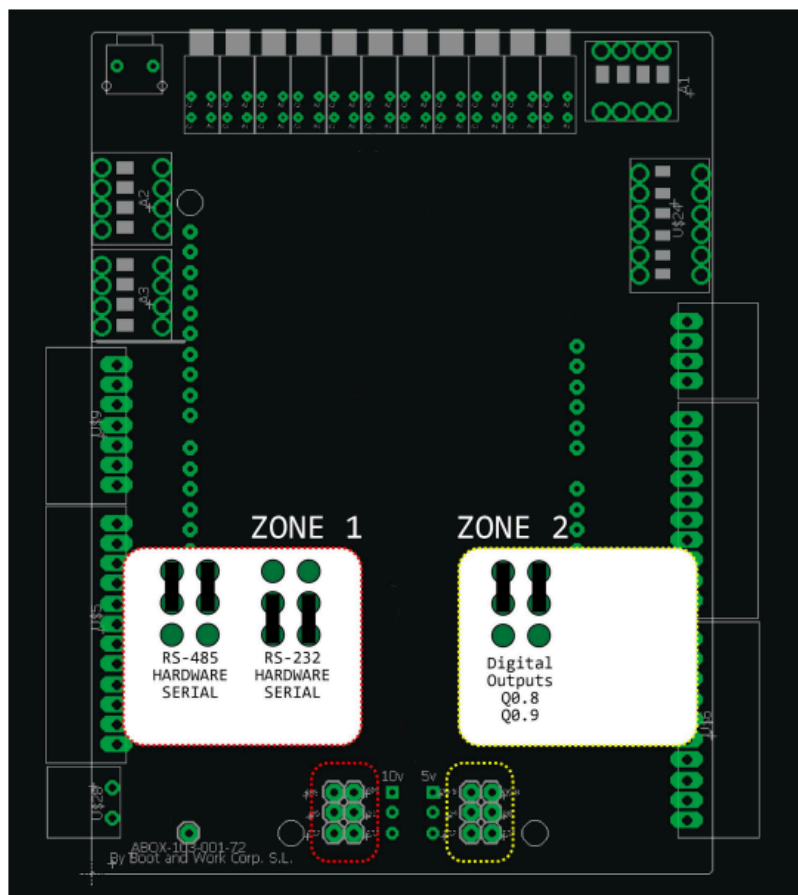

10.2 015001001300 Relay General Jumper Configuration

JUMPER ZONE 1	
LEFT	RIGHT
Y+	Z-
ENABLE	ENABLE
A0.0	A0.1

This jumper zone makes the selection between using the RS-485 Full Duplex or the Analog Outputs. If it is wanted to use the RS-485 Full Duplex communication protocol the Y+ must be connected to ENABLE, and Z- also connected to ENABLE. If it is wanted to use the Analog Outputs, the A0.0 must be connected to ENABLE, and A0.1 also connected to ENABLE.

JUMPER ZONE 2	
LEFT	RIGHT
I0.2	I0.3
D4	D8
RS-232	RS232

This jumper zone makes the choice between connecting the inputs Q0.9, Q0.8 to pins 4 and 8 of the Arduino Leonardo respectively, or connect the RS-232 ports to activate the Software Serial RS-232. In order to use the inputs Q0.9, Q0.8 the jumper must be connected to the pins 4 and 8. So Q0.9 must be connected with D4 and Q0.8 must be connected to D8.

JUMPER ZONE 3	
DOWN	UP
RS-485	RS-485
D0	D1
RS-232	RS-232

This jumper makes the choice between connecting MAX232 to pins 0,1 of the Arduino Leonardo or with the MAX485. In order to use the RS-232 Hardware Serial protocol both RS-232 must be connected to the D1/D0. In order to use the RS-485 Hardware Serial protocol both RS-485 must be connected to the D1/D0.

**The jumpers that are not connected to the middle jumpers MUST NOT be Connected anywhere.*

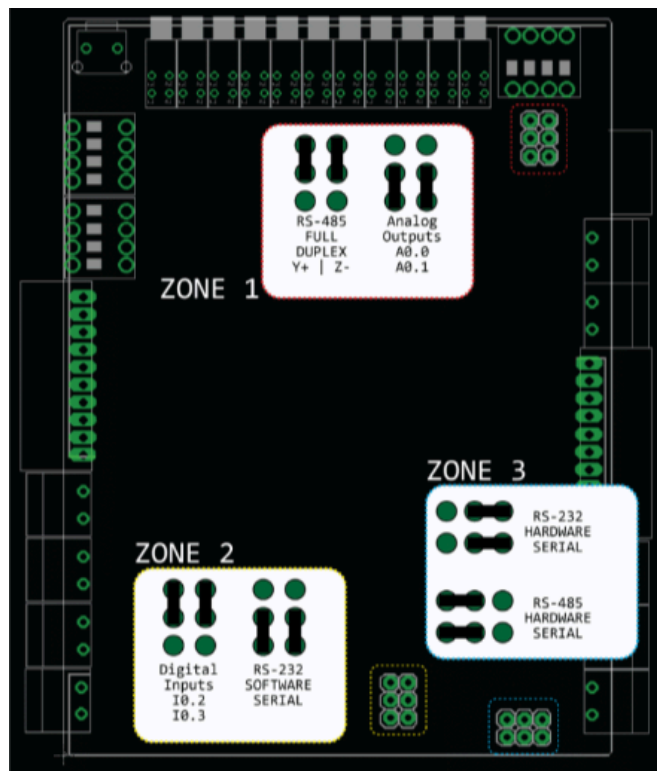

11. Hardware Serial RS-232 & RS-485 Configuration

11.1 015001001200 Analog Hardware Serial RS-485

In order to enable the Hardware Serial RS-485 the total configuration of the Ardbox Analog HF PLUS will be:

Switch configuration:

TOP ZONE		LEFT ZONE	
ACTIVATED SWITCH	MODE	ACTIVATED SWITCH	MODE
Q0.8	OFF	DE-RS485	ON
RS*	ON	DE-RS485	OFF
Q0.9	OFF	RE-RS485	ON
RS*	ON	RE-RS485	OFF
		LoRa / NC	-
		LoRa / NC	-

Jumper configuration:



- Available communication protocols:
 - Hardware Serial RS-485.
 - SPI
 - TTL (SoftwareSerial)
 - USB

11.2 015001001200 Analog Hardware Serial RS-232

In order to enable the Hardware Serial RS-232 the total configuration of the Ardbox Analog HF PLUS will be:

Switch configuration:

TOP ZONE		LEFT ZONE	
ACTIVATED SWITCH	MODE	ACTIVATED SWITCH	MODE
Q0.8	OFF	I0.8	OFF
RS*	ON	I0.8	ON
Q0.9	OFF	I0.9	OFF
RS*	ON	I0.9	ON
		LoRa / NC	-
		LoRa / NC	-

Note: The switches of the left zone of the RS-485 don't interfere in the RS-232 HS. As pins 0 & 1 are reserved for the RS-232, the RS-485 is totally disabled and there is no point on configuring these switches as RS-485 mode

Jumper configuration:

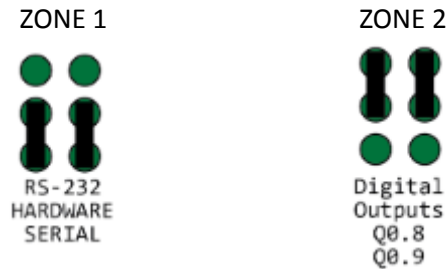

- Available communication protocols:
 - Hardware Serial RS-232.
 - SPI
 - TTL
 - USB

11.3 015001001300 Relay Hardware Serial RS-485

In order to enable the Hardware Serial RS-485 the total configuration of the Ardbox Relay HF PLUS will be:

Switch configuration:

TOP ZONE		LEFT ZONE	
ACTIVATED SWITCH	MODE	ACTIVATED SWITCH	MODE
RS*	ON	NC	-
R8	OFF	HD / FD	ON - OFF
RS*	ON	LoRa / NC	-
R7	OFF	LoRa / NC	-
		RE-RS485	ON
		RE-RS485	OFF
		DE-RS485	ON
		DE-RS485	OFF

Jumper configuration:

ZONE 1



ZONE 2



ZONE 3



- Available communication protocols:
 - Hardware Serial RS-485.
 - SPI
 - TTL
 - USB

11.4 015001001300 Relay Hardware Serial RS-232

In order to enable the Hardware Serial RS-232 the total configuration of the Ardbox Relay HF PLUS will be:

Switch configuration:

TOP ZONE		LEFT ZONE	
ACTIVATED SWITCH	MODE	ACTIVATED SWITCH	MODE
RS*	ON	NC	-
R8	OFF	HD / FD	ON - OFF
RS*	ON	LoRa / NC	-
R7	OFF	LoRa / NC	-
		I0.4	OFF
		I0.4	ON
		I0.5	OFF
		I0.5	ON

Jumper configuration:

ZONE 1



ZONE 2



ZONE 3



- Available communication protocols:
 - Hardware Serial RS-232.
 - SPI
 - TTL
 - USB

12. Ardbox - Arduino I/Os 5V pins

The Ardbox has one of the Leonardo board pins available. This pin can be programmed according to Arduino features such as I/Os operating at 5V. As the pin is directly connected to the Arduino Leonardo board they are not as well protected as the normal inputs. The pin is mainly meant to be used as prototyping.

Ardbox terminal	Arduino pin
MISO	14
SCK	15
MOSI	16

***IMPORTANT:** Do not connect the pin in the chart above to voltages higher than 5V. This terminal provides direct access to the Leonardo board.

12.1 SPI - MISO / MOSI / SCK

These pins are not established with a pull-up or a pull down configuration. The state of these pins is unknown. If these pins must be used, they require a pull-up or a pull-down configuration. The Arduino board allows the pins to be set in a pull-up configuration. If not it must be established as an external pull-up or pull-down circuit in order to correctly work with these pins.

13. LoRa Programming Examples

13.1 Introduction to LoRa

A brief explanation about LoRa can be found in this [post](#)⁶. LoRa is perfect for industrial projects due to its long-range capability and its affordability.

13.2 How to work with LoRaWAN

LoRaWAN is a low-power, wide-area networking protocol based on LoRa. Its usage in industrial environments and smart cities is very popular as it is easy to use and it uses the free and unlicensed ISM radio bands. Find how to work with LoRaWAN [here](#)⁷.

In the examples the communication with an M-Duino LoRa PLC is shown, but the process is identical with the Ardbox models. Select the correct Ardbox board in the Arduino IDE while doing any tutorial.

⁶ <https://www.industrialshields.com/blog/arduino-industrial-1/post/what-is-lora-254>

⁷ <https://www.industrialshields.com/blog/arduino-industrial-1/post/how-to-work-with-lorawan-and-a-plc-controller-255>

14. Digital inputs threshold detection

The Ardbox inputs have a minimum voltage threshold to reliably detect the signal when used as digital input. The threshold value is different depending on the input type:

Input type	Threshold voltage (V)
Digital input	3.7
Analog input	3.3

15. I/O technical details

Digital Output Waveform

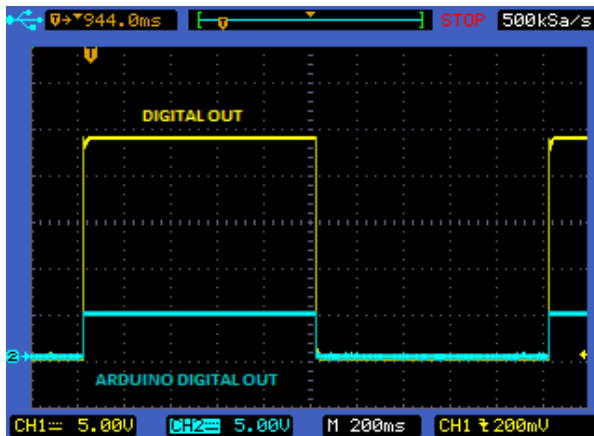

Digital Output Turn-off

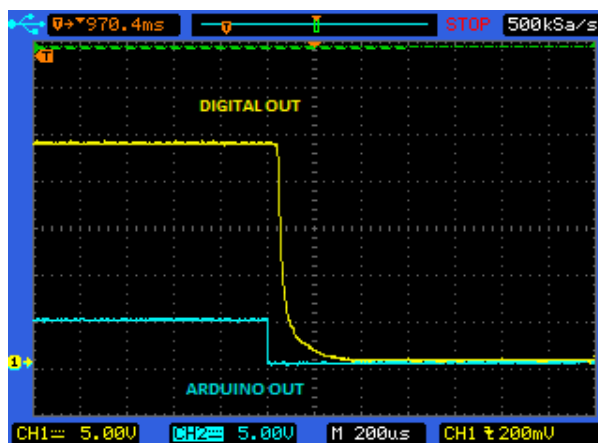

PWM Waveform

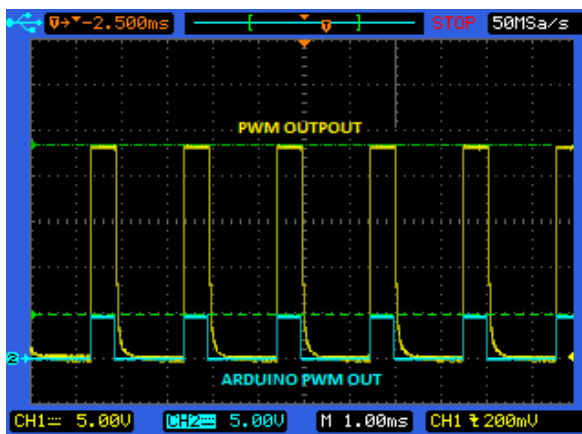

Analog Out Turn-on

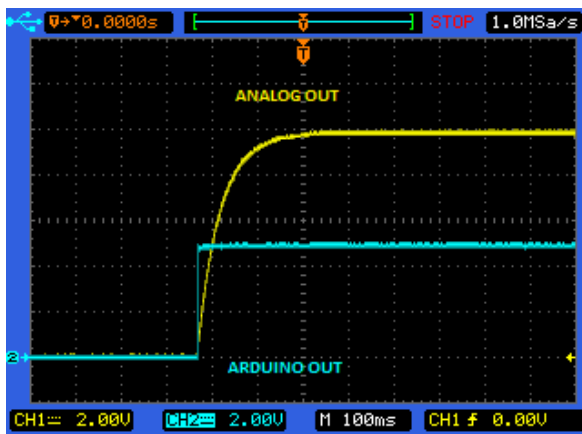

Analog Out Turn-off

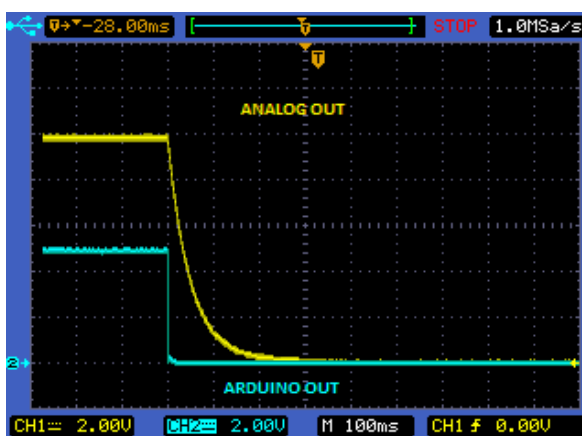

Analog/Digital Input Turn-on

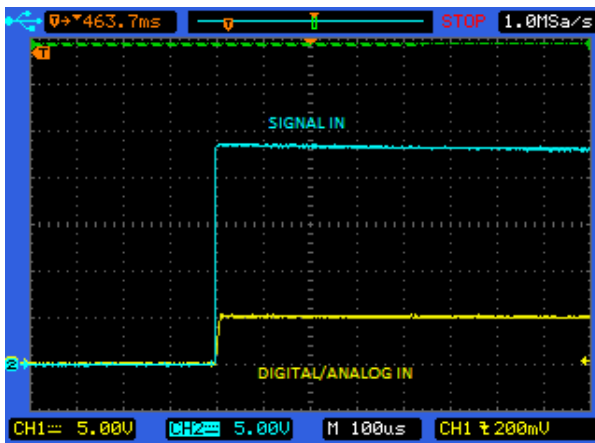

Analog/Digital Input Turn-off

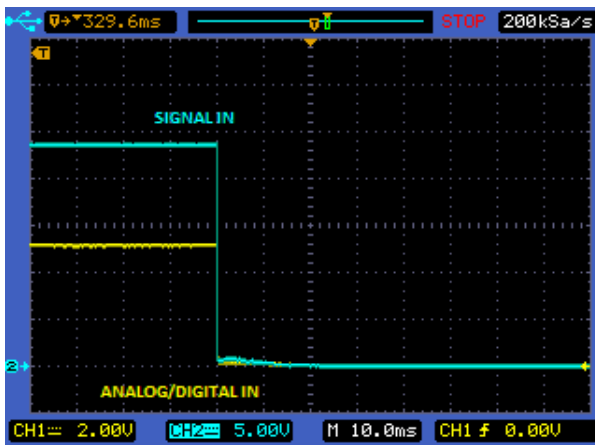

16. Typical Connections

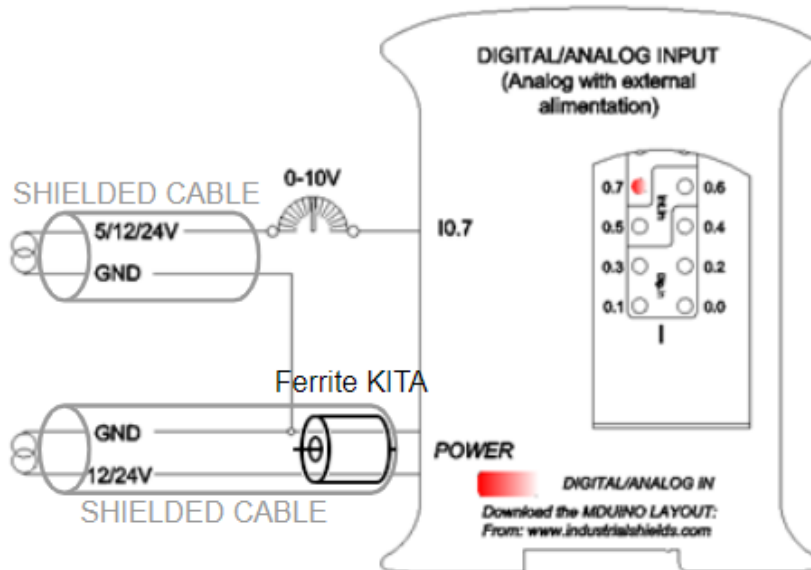
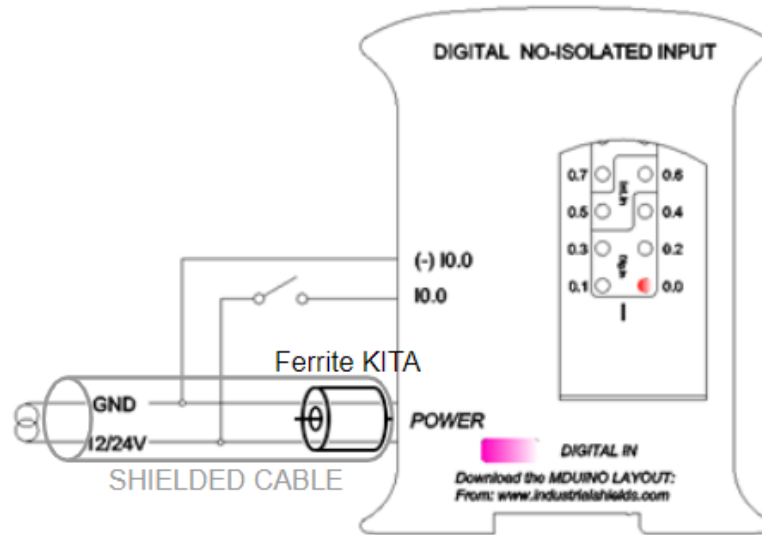

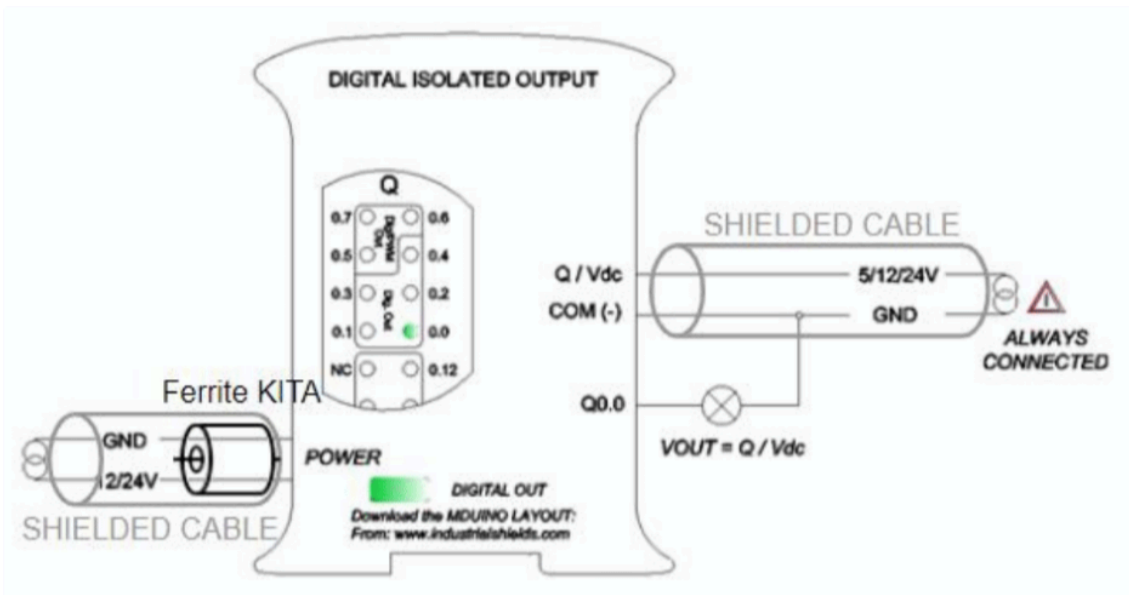
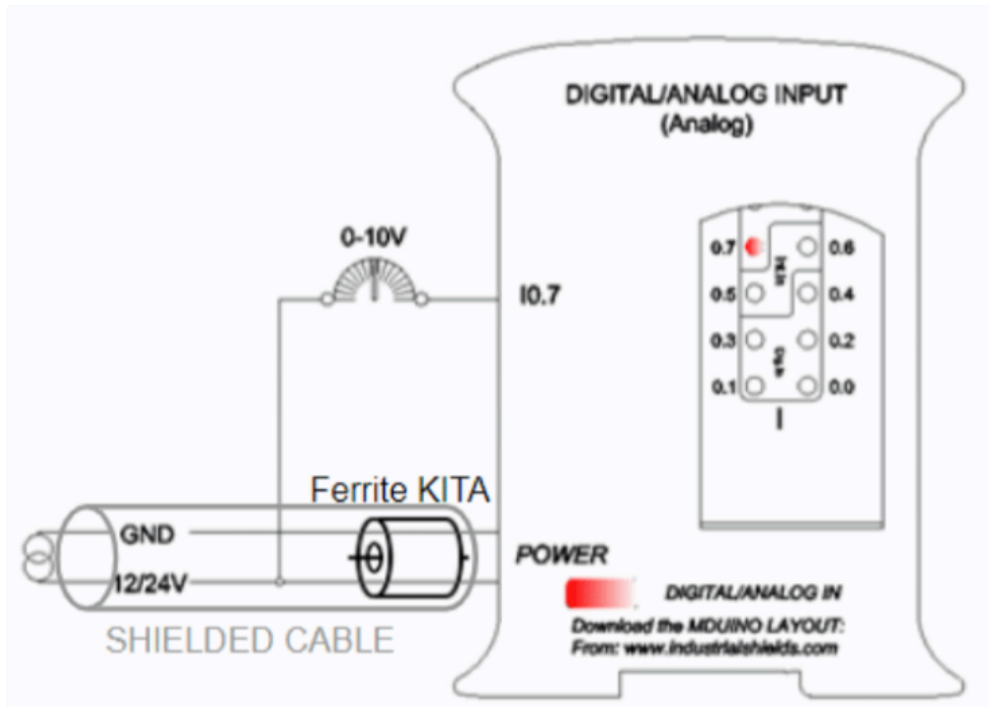

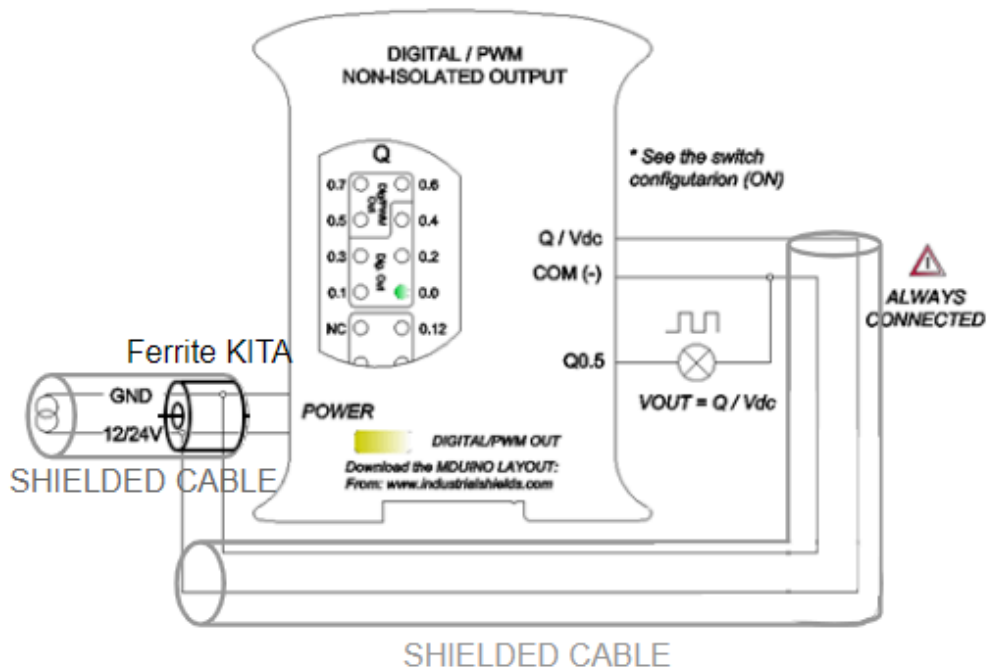
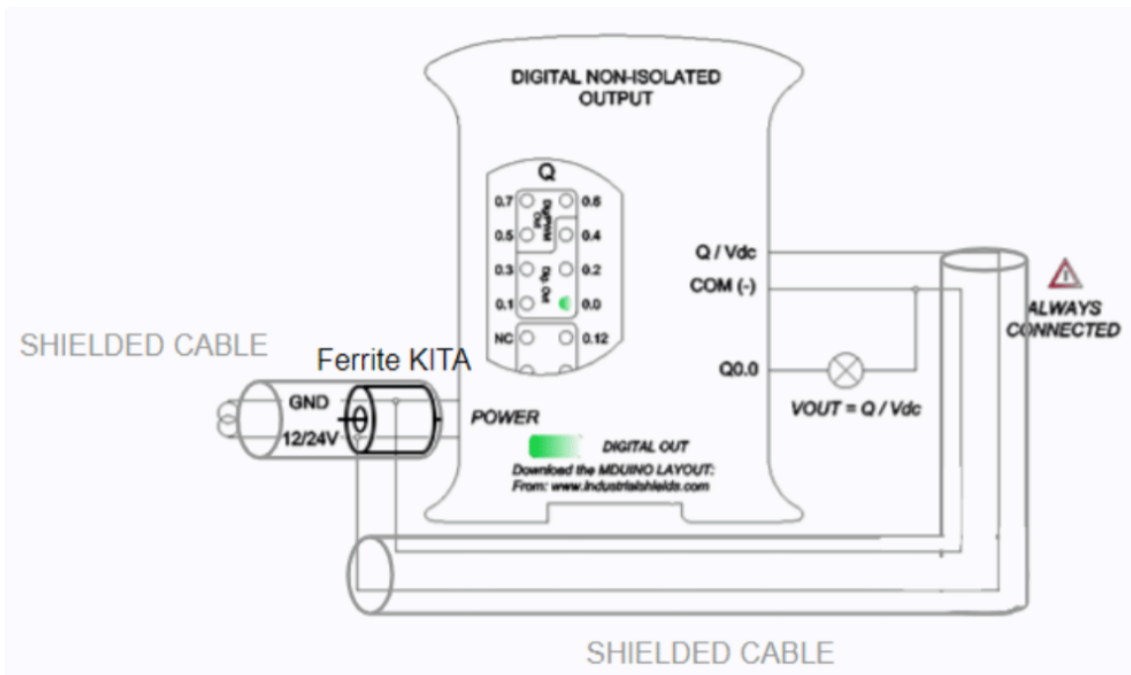

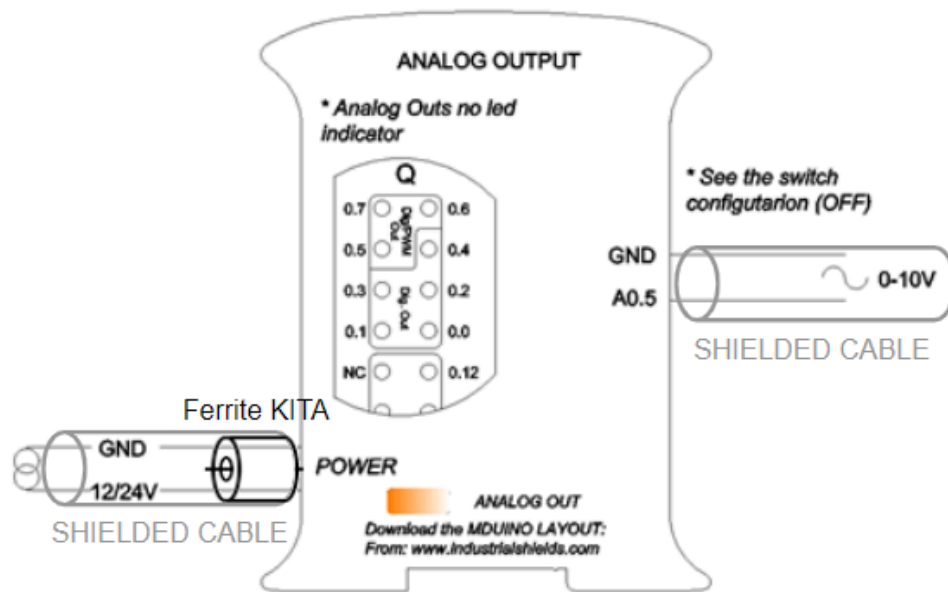

17.Connector details

The connector inside the PLCs that mounts on the PCB is MC 0,5/10-G-2,5 THT – 1963502 from Phoenix contact. MC0,5/10-G-2,5THT

For I/O and power supply there is a FK-MC 0,5/10-ST-2,5 - 1881406 connector from Phoenix contact. FK-MC 0,5/10-ST-2,5

Connection details:

Article reference	MC 0,5/10-G-2,5 THT
Height	8,1mm
Pitch	2,5mm
Dimension	22,5mm
Pin dimensions	0,8x0,8mm
Pin spacing	2,50mm

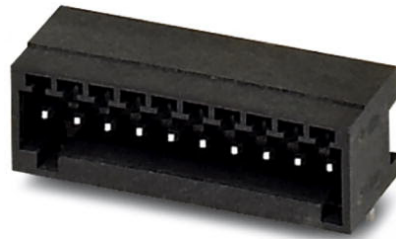

Article reference	FK-MC 0,5/10-ST-2,5
Rigid conduit section min.	0,14 mm ²
Rigid conduit section max.	0,5 mm ²
Flexible conduit section min.	0,14 mm ²
Flexible conduit section max.	0,5 mm ²
Conduit section AWG/kcmil min.	26
Conduit section AWG/kcmil max.	20

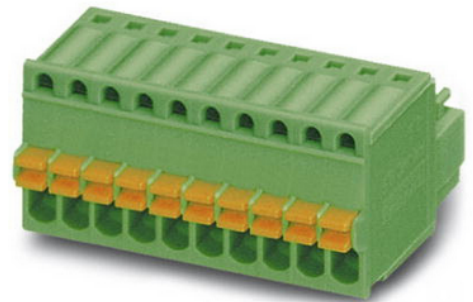

18.ARDBOX Family Dimensions

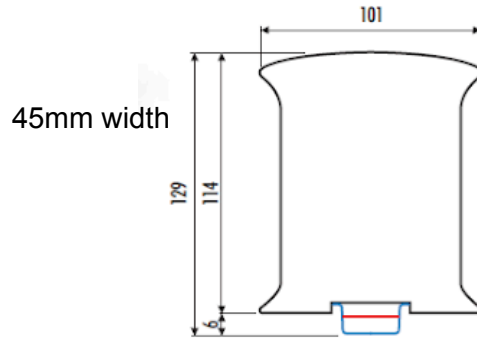

- DIN rail mounting:

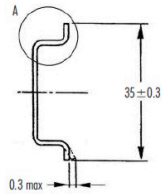
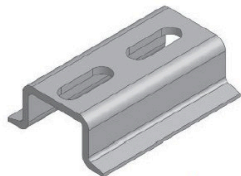

Profilato a cappello TH 35-7,5
Top hat rail TH 35-7,5

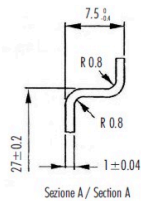

Profilato a cappello TH 35-15
Top hat rail TH 35-15

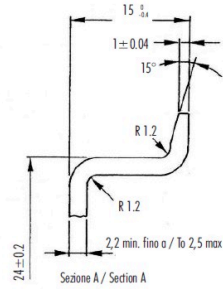

CARATTERISTICHE	METODO	UNITA' DI MISURA	BLENDE PC/ABS
Meccaniche	Resistenza a trazione allo spezzamento	ASTM D638	MPa 68
	Resistenza a trazione a rottura	ASTM D638	MPa 48
	Allungamento a rottura	ASTM D638	% 59
	Modulo di flessione	ASTM D790	MPa 2894
	Prova Izod con intaglio	ISO 180/14	KJ/m ² 5.5
Termiche	Tempo di scurimento Vicat metodo B	ASTM D1525	°C 114
	Temperatura Ricatto 1.81 MPa	ASTM D648	°C 97
Fisiche	Peso specifico	ASTM D792	g/cm ³ 1.21
	Ritiro nello stampo	ASTM D955	% 0.4/0.6
	Melt Flow Index 260°C - 98N	ASTM D1238	g/10V 11.1
Comportamento alla fiamma	Autoestinguenza (mm di spessore)	0.94	V-0 (0.8)
	Filo fusibile con 3.2 mm	IEC 695.2.1	°C 960

Italtronic si riserva il diritto di modificare il materiale con cui realizza i propri prodotti senza obbligo di preavviso.

FEATURES	TEST METHOD	UNITS	BLENDE PC/ABS
Mechanical test	Resistance to tensile stress at yield	ASTM D638	MPa 68
	Tensile strength	ASTM D638	MPa 48
	Elongation at rupture	ASTM D638	% 59
	Flexing modulus	ASTM D790	MPa 2894
	Izod test notched	ISO 180/14	KJ/m ² 5.5
Thermal test	Vicat softening temperature method B	ASTM D1525	°C 114
	Reheating temperature 1.81 MPa	ASTM D648	°C 97
Physical test	Specific gravity	ASTM D792	g/cm ³ 1.21
	Mold shrinkage	ASTM D955	% 0.4/0.6
	Melt Flow Index 260°C - 98N	ASTM D1238	g/10V 11.1
Flame test	Self extinguisher (thickness in mm)	0.94	V-0 (0.8)
	Fusible wire threaded 3.2 mm	IEC 695.2.1	°C 960

Italtronic can operate any change of the materials without being obliged to forewarn.

19. Installation and Maintenance

Notes for installation:

- The installation position should be free from the following: dust or oil smoke, conductive dust, corrosive or flammable gas, high temperature, condensation, and rain.
- Besides, vibration and impact also affect the PLC normal operation and shorten its lifespan; electric shock, fire or misact also damages the product. During drilling or wiring, prevent the metal particles or wire segments from falling into the PLC casing, which may cause fire, fault or misact.
- After the PLC installation, clean the ventilation duct to prevent blocking, which may cause bad ventilation, or even fire, faults or misact.
- Do not online connect, plug or unplug cables, which are apt to cause electric shock or damage the circuit. Installation and wire connection must be firm and reliable. Poor connection could cause a misact.
- Use shielded twisted pairs for the I/O of high frequency signal and analog signal to improve system IMS.

The installation environment should be free from dust, oil smoke, conductive particles, corrosive or flammable gases, high temperature, condensation, and rain.

Besides, vibration and impact also affect the PLC normal operation and shorten its lifespan. It is recommended to install the PLC, together with the matching switches and contactors, in a dedicated electric cabinet and keep the cabinet ventilated. If the location has high ambient temperature or heat generating equipment nearby, install forced convection devices on top or sides of the cabinet to avoid over-temperature. During drilling or wiring, prevent the metal particles or wire segments from falling into the PLC casing, which may cause fire, fault or misact. After the PLC installation, clean the ventilation duct to prevent blocking, which may cause bad ventilation, or even fire, faults or misact.

The only way to disconnect the equipment from the electrical network is by removing the connectors that feed the equipment. Once installed in the electrical cabinet it is very important to ensure the power connectors for proper operation.

Separate the ARDBOX 20 I/Os Family HF PLUS from heat, high voltage and electrical noise:

Always separate the devices that generate high voltage and high electrical noise from the ARDBOX 20 I/Os Family HF PLUS. When configuring the layout of the ARDBOX 20 I/Os Family HF PLUS inside your panel, consider the heat-generating devices and locate the electronic-type devices in the cooler areas of your cabinet. Reducing the exposure to a high-temperature environment will extend the operating life of any electronic device. Consider also the routing of the wiring for the devices in the electric cabinet. Avoid placing low-voltage signal wires and communications cables in the same tray with AC power wiring and high energy, rapidly-switched DC wiring.

Provide adequate clearance for cooling and wiring ARDBOX 20 I/Os Family HF PLUS. Is designed for natural convection cooling. For proper cooling, you must provide a clearance of at least 25cm above and below the devices. Also, allow at least 25cm of depth between the front of the modules and the inside of the enclosure.

Notes for maintenance:

A well-planned and executed maintenance program is essential to the satisfactory operation of solid-state electrical equipment. The kind and frequency of the maintenance operation will vary with the kind and complexity of the equipment as well as with the nature of the operating conditions. Maintenance recommendations of the manufacturer or appropriate product standards should be followed.

The following factors should be considered when formulating a maintenance program:

- Maintenance must be performed by qualified personnel familiar with the construction, operation, and hazards involved with the control.
- Maintenance should be performed with the control out of operation and disconnected from all sources of power.
- Care should be taken when servicing electrostatic sensitive components. The manufacturer's recommendations for these components should be followed.
- Ventilation passages should be kept open. If the equipment depends upon auxiliary cooling, e.g., air, water, or oil, periodic inspection (with filter replacement when necessary) should be made of these systems.
- The means employed for grounding or insulating the equipment from ground should be checked to assure its integrity.
- Accumulations of dust and dirt on all parts, including on semiconductor heat sinks, should be removed according to the manufacturer's instructions, if provided; otherwise, the manufacturer should be consulted. Care must be taken to avoid damaging any delicate components and to avoid displacing dust, dirt, or debris in a way that permits it to enter or settle into parts of the control equipment.
- Enclosures should be inspected for evidence of deterioration. Accumulated dust and dirt should be removed from the top of the enclosures before opening doors or removing covers.
- Certain hazardous materials removed as part of maintenance or repair procedure (e.g., polychlorinated biphenyls (PCBs) found in some liquid filled capacitors) must be disposed of as described in Federal regulations.

Safety rules for maintenance personnel

Consider the following steps to follow. A false manoeuvre could be the cause of an accident or material damage.

Do not disassemble or modify the modules. This could lead to breakdowns or malfunctions and could lead to injuries or fire.

- All types of radio communication devices, including mobile phones and personal handy-phone systems (PHS), must be kept more than **25cm** away from the PLC in all directions. Failure to observe this precaution exposes malfunctions caused by excess temperature.

- Disconnect the external power supply of the system (on all phases) before connecting or disconnecting a module. Failure to observe this precaution may cause faults or malfunctions of the module.
- Tighten the screws of the terminal ports and the screws of the connectors within the prescribed tightening torque. Insufficient tightening can lead to loose parts or wires and cause malfunctions. Excessive tightening can damage the screws and / or the module, with the risk of falling, short circuits and malfunctions.
- Before handling a module, dispose of the electrostatic charge accumulated by the human body by touching a suitable conductive object. Failure to observe this precaution may cause faults or malfunctions of the module.

Repair note:

If the equipment is suitable to be repaired, it must be verified that the equipment remains in a safe state after repair.

20.Revision Table

Revision Number	Date	Changes
0	30/08/2019	First implementation
1	04/03/2020	Second implementation
2	08/06/2023	Family Implementation
3	11/03/2024	Added section 14 "Digital inputs threshold detection"
4	13/03/2024	RS* Switches Revision
5	21/03/2024	Section 8.2 Digital inputs fix
6	02/07/2024	LoRa Switches Revision

About Industrial Shields:

Direction: Camí del Grau, 25

Zip/Postal Code: 08272

City: Sant Fruitós de Bages (Barcelona)

Country: Spain

Telephone: (+34) 938 760 191 / (+34) 635 693 611

Mail: industrialshields@industrialshields.com