



INDUSTRIAL SHIELDS

PLC 10 I/Os USER GUIDE

PLC 10 I/Os
USER GUIDE



PLC 10 I/Os User Guide

Revised November 2024

This user guide is for version PLC 10 I/Os with Reference name Ref. 013001000100, 013002000100, 013001000200 and 013002000200.

Preface

This User Guide has been implemented by Boot & Work, S.L. working under the name Industrial Shields.

Purpose of the manual

The information contained in this manual can be used as a reference to operate and get a better understanding of the technical data of the signal modules, power supply modules and interface modules.

Intended Audience

This User Guide is intended for the following audience:

- Persons in charge of introducing automation devices.
- Persons who design automation systems.
- Persons who install or connect automation devices.
- Persons who manage working automation installation.



Warnings:

- It must be used a micro USB-B type cable with the plastic part thin (contour of 2mm).

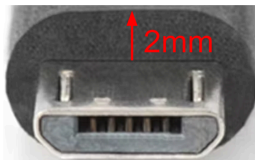

- Unused pins should not be connected. Ignoring the directive may damage the controller.
- Improper use of this product may severely damage the controller.
- Refer to the controller's User Guide regarding wiring considerations.
- Before using this product, it is the responsibility of the user to read the product's User Guide and all accompanying documentation.
- Maintenance must be performed by qualified personnel familiarized with the construction, operation, and hazards involved with the control.

- Maintenance should be performed with the control out of operation and disconnected from all sources of power.
- Care should be taken when servicing electrostatic sensitive components. The manufacturer's recommendations for these components should be followed.
- The 10 I/Os PLCs are Open Type Controllers. It is required that you install the 10 I/Os PLC in a housing, cabinet, or electric control room. Entry to the housing, cabinet, or electric control room should be limited to authorized personnel. Failure to follow these installation requirements could result in severe personal injury and/or property damage. Always follow these requirements when 10 I/Os PLCs.
- In case of installation or maintenance of the 10 I/Os please follow the instructions marked in the Installation and Maintenance section.
- Do not disconnect equipment when a flammable or combustible atmosphere is present. Disconnection of equipment when a flammable or combustible atmosphere is present may cause a fire or explosion which could result in death, serious injury and/or property damage.



Avertissements:

Il faut utiliser un câble de type micro USB-B avec la partie plastique fine (contour de 2mm).

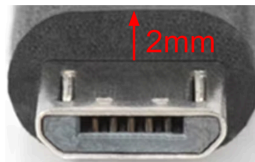

Les broches non utilisées ne doivent pas être connectées. Ignorer la directive peut endommager le contrôleur.

Une utilisation incorrecte de ce produit peut endommager gravement le contrôleur.

Reportez-vous au Guide de l'utilisateur du contrôleur pour les considérations de câblage.

Avant d'utiliser ce produit, il incombe à l'utilisateur de lire le Guide de l'utilisateur du produit et la documentation qui l'accompagne.

La maintenance doit être effectuée par personnel qualifié familiarisé avec la fabrication, le fonctionnement et les dangers liés au contrôleur.

La maintenance doit être effectuée avec l'équipement hors service et déconnectée de toutes les sources d'alimentation.

Faites attention lors de l'entretien des composants sensibles à l'électricité statique. Les recommandations du fabricant pour ces composants doivent être suivies.

Les automates de la famille 10 I/Os sont des contrôleurs de type ouvert. Il est nécessaire d'installer l'automate 10 I/Os dans un boîtier, une armoire ou une salle de

contrôle électrique. L'accès au boîtier, à l'armoire ou à la salle de commande électrique doit être limité au personnel autorisé. Le non-respect de ces exigences d'installation peut entraîner des blessures graves et/ou des dommages matériels importants. Respectez toujours ces exigences lors de l'installation des automates de la famille 10 I/Os.

En cas d'installation ou de maintenance du 10 I/Os, veuillez suivre les instructions indiquées dans la section Installation et Maintenance.

Ne débranchez pas l'équipement en présence d'une atmosphère inflammable ou combustible. La déconnexion de l'équipement en présence d'une atmosphère inflammable ou combustible peut provoquer un incendie ou une explosion pouvant entraîner la mort, des blessures graves et/ou des dommages matériels.

Application Considerations and Warranty

Read and Understand this Manual

Please read and understand this manual before using the product. Please consult your comments or questions to Industrial Shields before using the product.

Application Consideration

THE PRODUCTS CONTAINED IN THIS DOCUMENT ARE NOT SAFETY RATED. THEY SHOULD NOT BE RELIED UPON AS A SAFETY COMPONENT OR PROTECTIVE DEVICE FOR ENSURING SAFETY OF PERSONS, AS THEY ARE NOT RATED OR DESIGNED FOR SUCH PURPOSES.

Please know and observe all prohibitions of use applicable to the products.

FOR AN APPLICATION INVOLVING SERIOUS RISK TO LIFE OR PROPERTY WITHOUT ENSURING THAT THE SYSTEM AS A WHOLE HAS BEEN DESIGNED TO ADDRESS THE RISKS, NEVER USE THE INDUSTRIAL SHIELDS PRODUCTS.

NEVER USE THE INDUSTRIAL SHIELDS PRODUCTS BEFORE THEY ARE PROPERLY RATED AND INSTALLED FOR THE INTENDED USE WITHIN THE OVERALL EQUIPMENT OR SYSTEM.

Industrial Shields shall not be responsible for conformity with any codes, regulations or standards that apply to the combination of products in the customer's application or use of the product.

The following are some examples of applications for which particular attention must be given. This is not intended to be an exhaustive list of all possible uses of the products, nor is it intended to imply that the uses may be suitable for the products:

- Systems, machines, and equipment that could present a risk to life or property.
- Nuclear energy control systems, combustion systems, railroad systems, aviation systems, medical equipment, amusement machines, vehicles, safety

equipment, and installation subject to separate industry or government regulations.

- Outdoor use, uses involving potential chemical contamination or electrical interference, or conditions or uses not described in this document.

At the customer's request, INDUSTRIAL SHIELDS will provide applicable third-party certification documents identifying ratings and limitations of use that apply to the products. This information by itself is not sufficient for a complete determination of the suitability of the products in combination with the system, machine, end product, or other application or use.

Intended use or of Industrial Shields products

Consider the following:

Industrial Shields products should only be used for the cases of application foreseen in the catalogue and the associated technical documentation. If third-party products and components are used, they must have been recommended or approved by Industrial Shields.

The correct and safe operation of the products requires that your transport, storage, installation, assembly, operation and maintenance have been carried out in a correct manner. It must respect the permissible ambient conditions. You should also follow the indications and warnings that appear in the associated documentation.

The product / system dealt with in this documentation should only be handled or manipulated by qualified personnel for the task entrusted and observing what is indicated in the documentation corresponding to it, particularly the safety instructions and warnings included in it. Due to their training and experience, qualified personnel are in a position to recognize risks resulting from the handling or manipulation of such products / systems and to avoid possible hazards.

Disclaimers

Weights and Dimensions

Dimensions and weights are nominal and they are not used for manufacturing purposes, even when tolerances are shown.

Performance Data

The performance data given in this manual is provided as a guide for the user in determining suitability and does not constitute a warranty. It may represent the result of INDUSTRIAL SHIELDS's test conditions, and the users must correlate it to actual application requirements. Actual performance is subject to the INDUSTRIAL SHIELDS Warranty and Limitations of Liability.

Change in Specifications

Product specifications and accessories may be changed at any time based on improvements and other reasons.

It is our practice to change model numbers when features are changed, or published ratings or when significant construction changes are made. However, some specifications of the products may be changed without any notice. When in doubt, special numbers may be assigned to fix or establish key specifications for your application on your request. Please consult with your INDUSTRIAL SHIELDS representative at any time to confirm actual specifications of purchased products.

Errors and Omissions

The information in this document has been carefully checked and is believed to be accurate; however, no responsibility is assumed for clerical, typographical, or proofreading errors, or omissions.

Residual Risks

The control and drive components of an Industrial Shields PLC are approved for industrial and commercial use in industrial line supplies. Their use in public line supplies requires a different configuration and/or additional measures. These components may only be operated in closed housings or in higher-level control cabinets with protective covers that are closed, and when all of the protective devices are used. These components may only be handled by qualified and trained technical personnel who are knowledgeable and observe all of the safety information and instructions on the components and in the associated technical user documentation. When carrying out a risk assessment of a machine in accordance with the EU Machinery Directive, the machine manufacturer must consider the following residual risks associated with the control and drive components of a PDS.

1. Unintentional movements of driven machine components during commissioning, operation, maintenance, and repairs caused by, for example: – Hardware defects and/or software errors in the sensors, controllers, actuators, and connection technology – Response times of the controller and drive – Operating and/or ambient conditions not within the scope of the specification – Condensation / conductive contamination – Parameterization, programming, cabling, and installation errors – Use of radio devices / cellular phones in the immediate vicinity of the controller – External influences / damage.
2. Exceptional temperatures as well as emissions of noise, particles, or gas caused by, for example: – Component malfunctions – Software errors – Operating and/or ambient conditions not within the scope of the specification – External influences / damage.
3. Hazardous shock voltages caused by, for example: – Component malfunctions – Influence of electrostatic charging – Induction of voltages in moving motors – Operating and/or ambient conditions not within the scope of the specification – Condensation / conductive contamination – External influences / damage

4. Electrical, magnetic and electromagnetic fields generated in operation that can pose a risk to people with a pacemaker, implants or metal replacement joints, etc. if they are too close.

5. Release of environmental pollutants or emissions because of improper operation of the system and/or failure to dispose of components safely and correctly.

Warranty and Limitations of Liability

Warranty

Industrial Shields's exclusive warranty is that the products are free from defects in materials and workmanship for a period of one year (or other period if specified) from date of sale by Industrial Shields.

INDUSTRIAL SHIELDS MAKES NO REPRESENTATION OR WARRANTY, EXPRESSED OR IMPLIED, REGARDING MERCHANTABILITY, NON-INFRINGEMENT, OR FITNESS FOR PARTICULAR PURPOSE OF THE PRODUCTS. ANY BUYER OR USER ACKNOWLEDGES THAT THE BUYER OR USER ALONE HAS DETERMINED THAT THE PRODUCTS WILL SUITABLY MEET THE REQUIREMENTS OF THEIR INTENDED USE. INDUSTRIAL SHIELDS DISCLAIMS ALL OTHER WARRANTIES, EXPRESS OR IMPLIED

Limitations of Liability

INDUSTRIAL SHIELDS SHALL NOT BE RESPONSIBLE FOR SPECIAL, INDIRECT, OR CONSEQUENTIAL DAMAGES, LOSS OF PROFITS OR COMERCIAL LOSS IN ANY WAY CONNECTED WITH THE PRODUCTS, WHETHER SUCH CLAIM IS BASED ON CONTRACT, WARRANTY, NEGLIGENCE, OR STRICT LIABILITY.

IN NO EVENT SHALL INDUSTRIAL SHIELDS BE RESPONSIBLE FOR WARRANTY, REPAIR OR OTHER CLAIMS REGARDING THE PRODUCTS UNLESS INDUSTRIAL SHIELDS'S ANALYSIS CONFIRMS THAT THE PRODUCTS WERE PROPERLY HANDLED, STORED, INSTALLED, AND MAINTAINED AND NOT SUBJECT TO CONTAMINATION, ABUSE, MISUSE, OR INAPPROPRIATE MODIFICATION OR REPAIR.

Table of Contents



1. 10 I/Os Module: General Features	10
2. Technical Specifications	11
2.1 General Specifications:.....	11
2.2 Performance Specification:.....	12
2.3 Symbology.....	13
3. Precautions	14
3.1 Intended Audience.....	14
3.2 General Precautions.....	14
3.3 Isolation Precautions.....	14
4. Software interface	15
5. How to connect 10 IOs to PC	18
6. How to connect PLC to power supply	19
7. 10 I/Os serigraphy	20
7.1 Digital Module.....	20
7.1.1 Left Zone Connections.....	20
7.1.2 Right Zone Connections.....	20
7.2 Relay Module.....	21
7.2.1 Left Zone Connections.....	21
7.2.2 Right Zone Connections.....	21
8. Jumper configuration	23
8.1 General Jumper configuration. Digital Model.....	23
8.2 General Jumper configuration. Relay Model.....	25
8.3 I/Os Configuration examples.....	26
9. Software set up	30
9.1 Example.....	30
10. I/Os Communications	32
10.1 RS485.....	32
10.2 Ethernet.....	32
10.3 WiFi & BLE.....	33
General Specifications.....	33
11. Typical Connections	34
12. Connector details	35
13. 10 I/Os Dimensions:	36
14. Installation and Maintenance	37
15. Revision Table	40

1. 10 I/Os Module: General Features

COMPACT PLC 10 I/Os MODULE PLC		
Input Voltage	12 to 24Vdc — — —	Fuse protection (2.5A) Polarity protection
Input rated voltage	24Vdc — —	
Rated Power	30W	
I Max.	1,5A	
Size	100x45x115	
Clock Speed	External: 240 MHz Internal: 8 MHz	
External Flash Memory	4MB	
SRAM	4 MB	
PSRAM	2 MB	
Communications	USB - RS485 – ETH – WiFi – BLE	MAX487CSA - W5500
MAX Input points	10	
MAX Output points	10	
Digital Input 10bit 3,3 – 24Vdc	3.3 to 24Vdc Freq: 10 Hz Input Impedance: 27K Separated PCB ground I min: 2 to 12mA Opto-isolation Rated Voltage: 24 Vdc — — —	
Digital Isolated Output Relay	30Vdc / 250Vac Galvanic Isolation Diode protected for Relay — — —	I _{max} : 3A (30Vdc) I _{max} : 5A (250Vac)
Expandability	USB – RS485 – ETH – WiFi – BLE	
Reference	See Reference Table .	

2. Technical Specifications

2.1 General Specifications:







Power supply voltage	DC power supply	12 to 24Vdc 
Operating voltage range	DC power supply	11.4 to 25.4Vdc 
Power consumption	DC power supply	30W max.
External power supply	Power supply voltage	24Vdc 
	Power supply output capacity	300mA
Insulation resistance		20M Ω min. at 500Vdc between the AC terminals and the protective ground terminal.
Dielectric strength		2.300Vac at 50/ 60 Hz for one minute with a leakage current of 10mA max. Between all the external AC terminals and the protective earth terminal.
Shock resistance		80m/s ² in the X, Y and Z direction 2 times each.
Ambient temperature (operating)		0° to 60°C
Ambient humidity (operating)		10% to 90% (no condensation)
Ambient environment (operating)		With no corrosive gas
Ambient temperature (storage)		-20° to 60°C
Power supply holding time		2ms min.
Weight		350g max.

2.2 Performance Specification:

Board	ESP32 DevKit C (3.3V)
Control method	Stored program method
I/O control method	Combination of the cyclic scan and immediate refresh processing methods.
Programming language	Arduino IDE. Based on wiring (Wiring is an Open Source electronics platform composed of a programming language. "similar to the C". http://arduino.cc/en/Tutorial/HomePage)
Microcontroller	ESP32
External Flash Memory	4MB
Program capacity (SRAM)	4MB
PSRAM	2MB
Clock Speed	8MHz

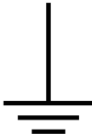
2.3 Symbology

Table that includes all the symbology that is used in the serigraph of the PLC 10 I/Os Module:

Symbol	Standard No. / Standard Title	Standard Reference No. / Symbol Title	Symbol Meaning
	IEC 60417 / Graphical symbols for use on equipment	5031 / Direct Current	Indicates that the equipment is suitable for direct current only; to identify relevant terminals
	IEC 60417 / Graphical symbols for use on equipment	5032 / Alternating Current	Indicates that the equipment is suitable for alternating current only; to identify relevant terminals
	IEC 60417 / Graphical symbols for use on equipment	5130 / Pulse General	To identify the control by which a pulse is started.
	IEC 60417 / Graphical symbols for use on equipment	5017 / Earth, Ground	To identify an earth (ground) terminal in cases where neither the symbol 5018 nor 5019 is explicitly required.
	IEC 60417 / Graphical symbols for use on equipment	5115 / Signal lamp	To identify the switch by means of which the signal lamp(s) is (are) switched on or off.
	2004/108/EC / Electromagnetic Compatibility	CE Marking	CE marking indicates that a product complies with applicable European Union regulations
	ISO 7000/ Graphical symbols for use on equipment	0434B / Warning symbol	Indicates a potentially hazardous situation which, if not avoided, could result in death or serious injury
	ISO 7000/ Graphical symbols for use on equipment	5036 / Dangerous Voltage	To indicate hazards arising from dangerous voltages

3. Precautions

Read this manual before attempting to use the 10 I/Os PLC and follow its descriptions for reference during operation.

3.1 Intended Audience

This manual is intended for technicians, which must have knowledge on electrical systems.

3.2 General Precautions

The user must operate 10 I/Os Module according to the performance specifications described in this manual.

Before using 10 I/Os PLC under different conditions from what has been specified in this manual or integrating 10 I/Os Module to nuclear control systems, railroad systems, aviation systems, vehicles, combustion systems, medical equipment, amusement machines, safety equipment and other systems, machines, and equipment that may have a serious influence on lives and property if used improperly, consult your INDUSTRIAL SHIELDS representative. Ensure that the rating and performance characteristics of 10 I/Os Module are sufficient for the systems, machines, and equipment, and be sure to provide the systems, machines, and equipment double safety mechanisms. This manual provides information for programming and operating the 10 I/Os Module.

3.3 Isolation Precautions

Description:

This equipment does **not include galvanic isolation between the grounds** of the different systems. This means that if an external device or sensor that shares the same ground reference (GND) with the system is connected, any potential difference between these grounds could damage the connected components. To avoid issues with interference, ground loops, or damage to external equipment, ensure that all connected devices share the same ground reference or use systems with appropriate isolation.

Recommendations:

- **Connection Review:** Verify that all ground connections are properly made and that there are no significant potential differences between them.
- **Use of Isolation:** Consider using galvanic isolators or isolation transformers if it is necessary to connect equipment with different ground references.

4. Reference table

013001000100	10 I/O's Digital Module - CPU Arduino NANO
013002000100	10 I/O's Digital Module - CPU ESP32
013001000200	10 I/O's Relay Module - CPU Arduino NANO
013002000200	10 I/O's Relay Module - CPU ESP32

5. Software interface

Industrial Shields PLC are programmed using Arduino IDE, which is a software based on the C language. They can also be programmed directly using C but it is much easier working with Arduino IDE as it provides lots of libraries that help in the programming.

Furthermore, Industrial Shields provide boards for programming the PLCs much easier. Basically, it is not needed to define the pins and if those pins are inputs or outputs. Everything is set up automatically if using the boards.

In order to install Industrial Shields boards, these are the steps that must be followed.

Requirements:

Arduino IDE 1.8.0 or above (better to always have the latest version).

Steps:

1. Open Arduino IDE and go to: "File -> Preferences" located in the top left corner.

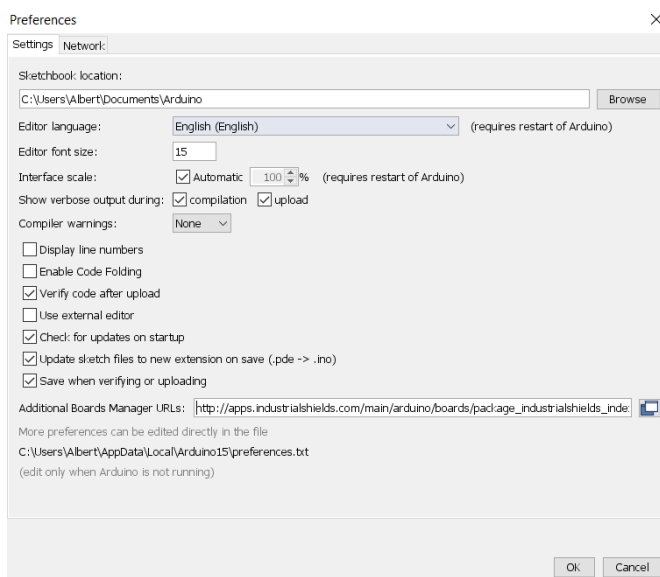

2. In Additional Boards URLs write the following:

http://apps.industrialshields.com/main/arduino/boards/package_industrialshields_index.json

If you already have an URL inserted, input an “,” between both URLs.

3. Press OK to save the changes.

4. Go to: Tools -> Board: ... -> Boards Manager

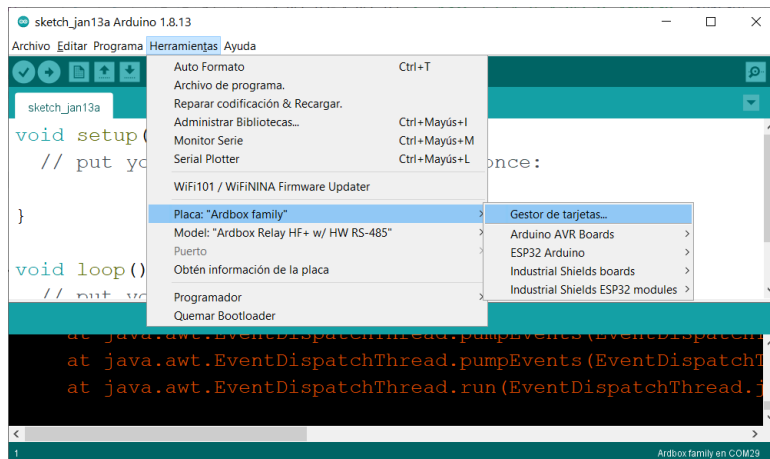

5. Search for industrialshields.

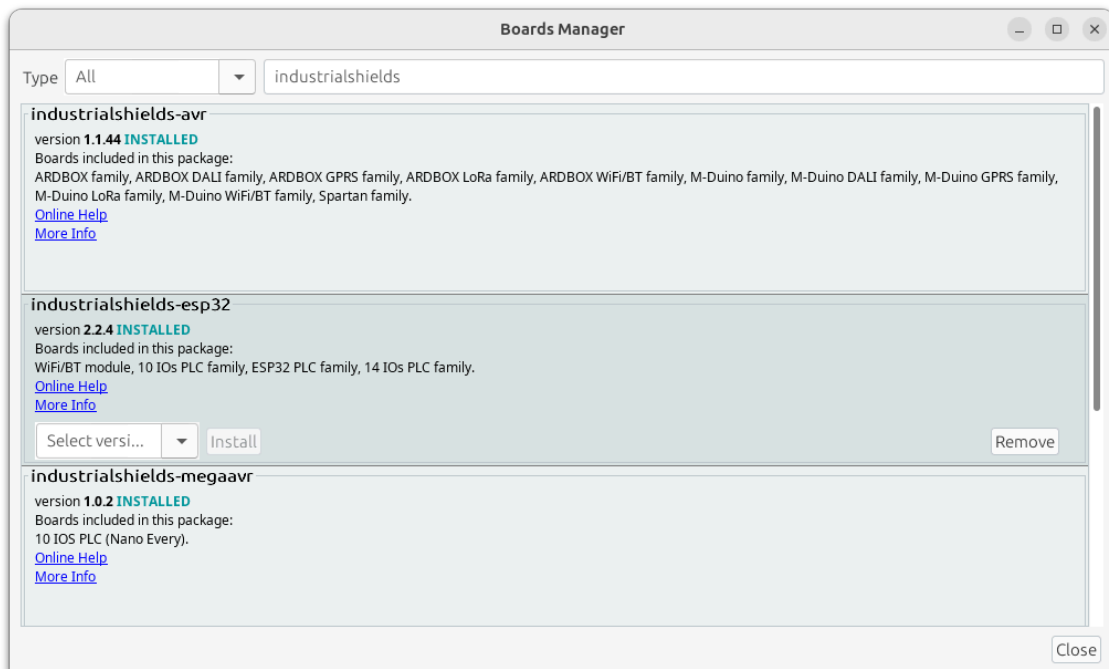

6. Depending on your CPU:

- a. If you have a model based on ESP32: click install *industrialshields-esp32* (selecting the latest version).

Following these steps you will be able to use now the Industrial Shields Boards:

> Tools > Board > Industrial Shields ESP32 Boards > 10IOs PLC Family

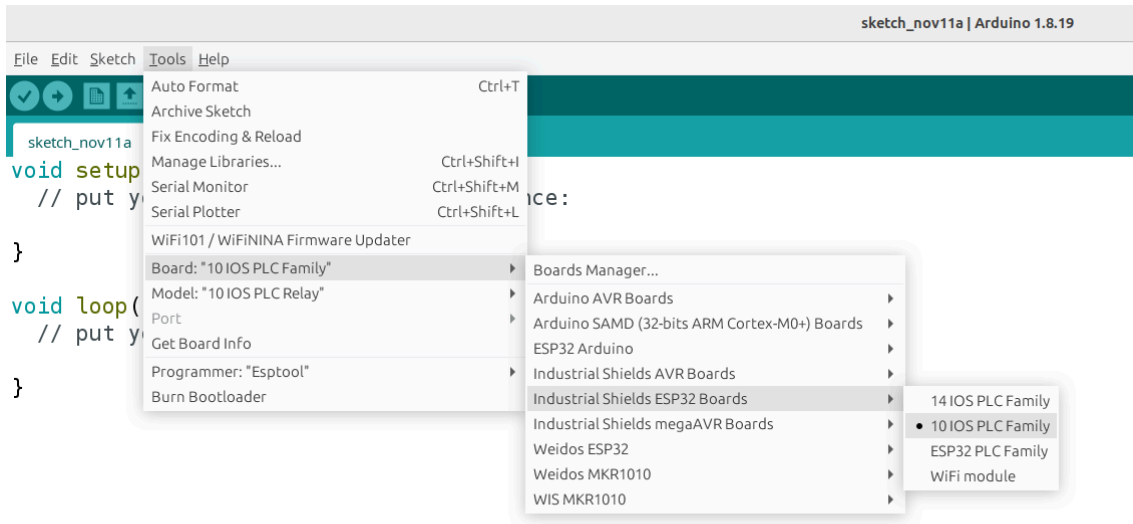

Once it is selected the 10 IOs PLC in Industrial Shields ESP32, an extra option will appear on Tools:

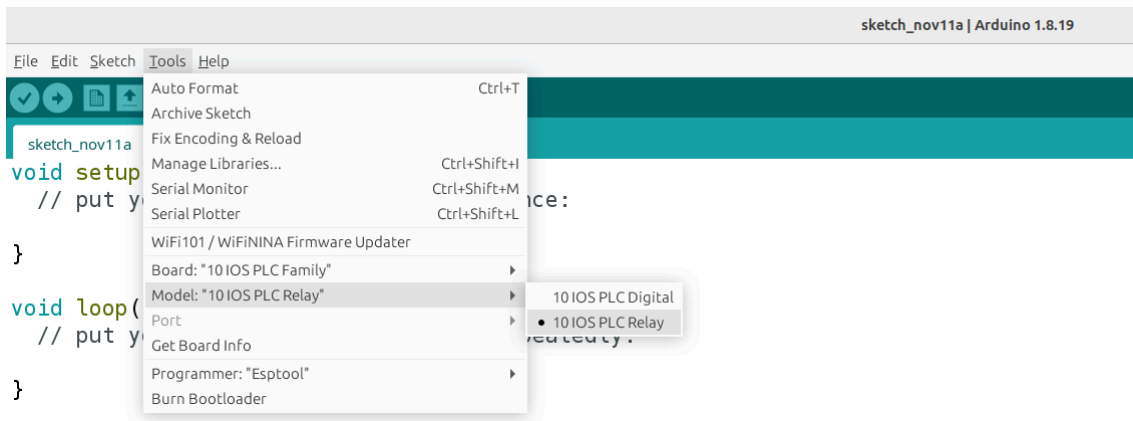

There, it can be selected the exact model for every family. In this case **10 IOs PLC Relay**.

Install the following driver referenced in this post depending on the operating system you use in order to work comfortably with the ESP32-based PLC.

https://www.industrialshields.com/blog/arduino-industrial-1/esp32-based-plc-with-windows-macintosh-troubleshooting-363?srsId=AfmBOoqY_o5TIYITnVcc7pkPtSU0mEPcGdvsc7N6E5IBOP4ypaqSDAro

- b. If you have a model based on Arduino Nano: click install *industrialshields-megaavr* (selecting the latest version).

Following these steps you will be able to use now the Industrial Shields Boards:

> Tools > Board > Industrial Shields megaAVR Boards > 10IOs PLC Family

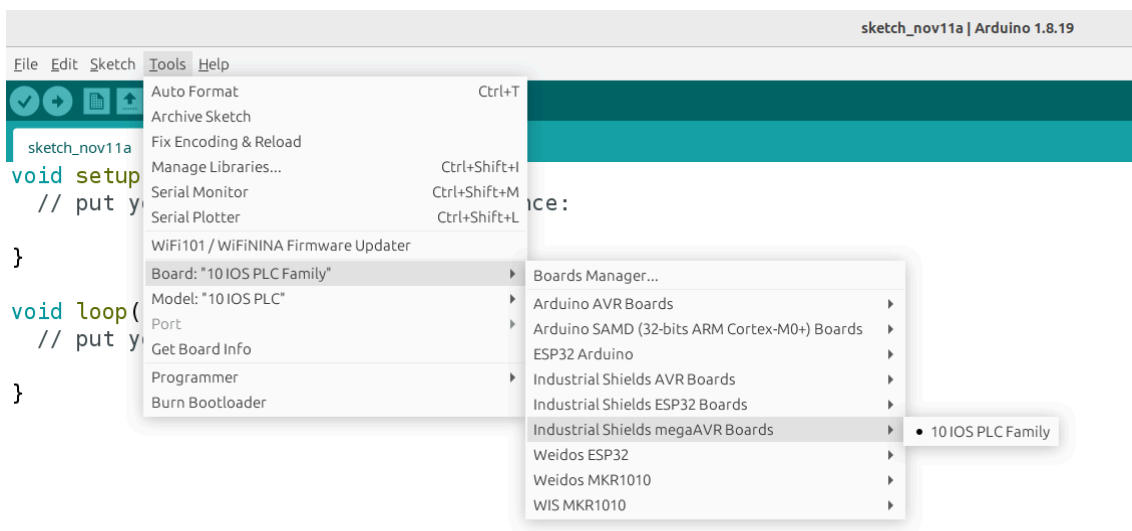

Once it is selected the 10 IOs PLC in Industrial Shields ESP32, an extra option will appear on Tools:

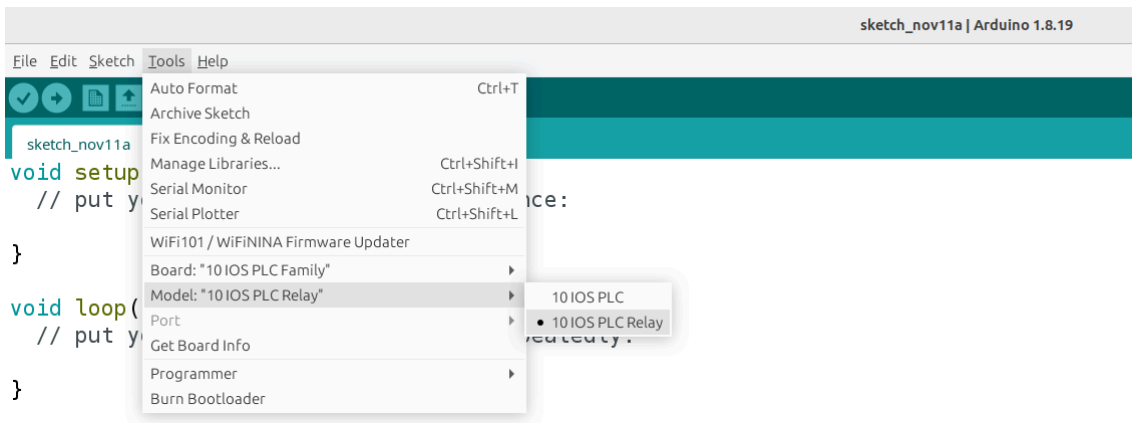

There, it can be selected the exact model for every family. In this case **10 IOs PLC Relay**.

Also, there are some examples of programming in File -> Examples -> 10 I/Os PLC Family.

Furthermore, there are some extra libraries that can be found in Industrial Shields GitHub.

<https://github.com/Industrial-Shields/>

6. How to connect 10 IOs to PC

- Connect USB port from PLC to PC.

NOTE:
10 I/Os PLC uses micro USB cable.



- Open Arduino IDE interface:
- Select the correct board.
- Select the correct port.

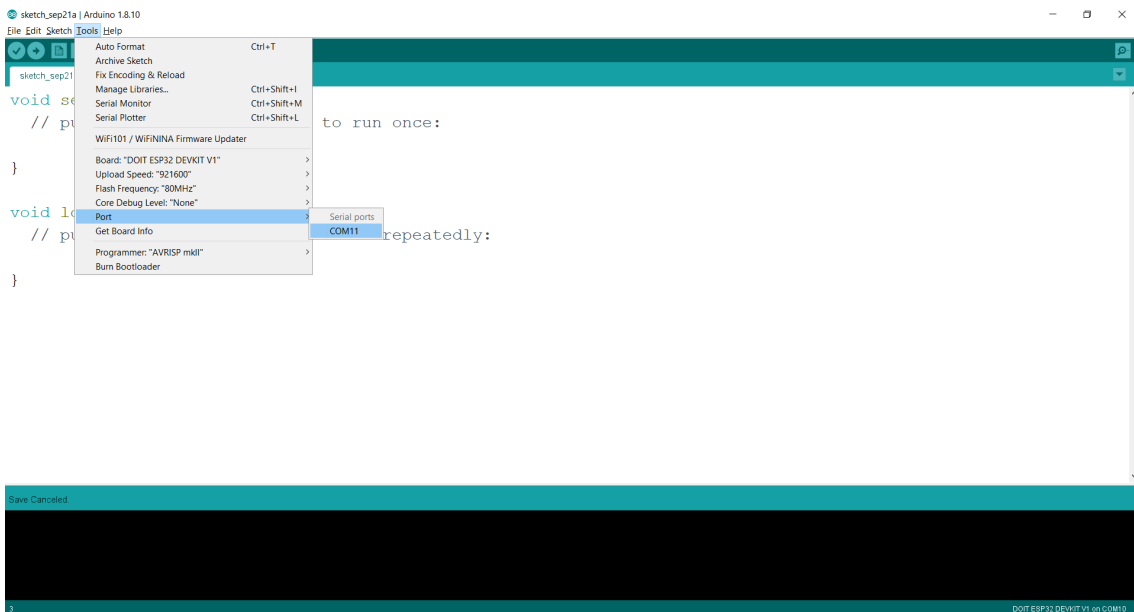

7. How to connect PLC to power supply

- 10 I/Os PLCs are 12-24Vdc supplied. **IMPORTANT: The polarity IS NOT REVERSAL!**
- Make sure that the live and GND connector of the power supply match the PLC.
- Make sure that the power supply mains output is not higher than 24Vdc.

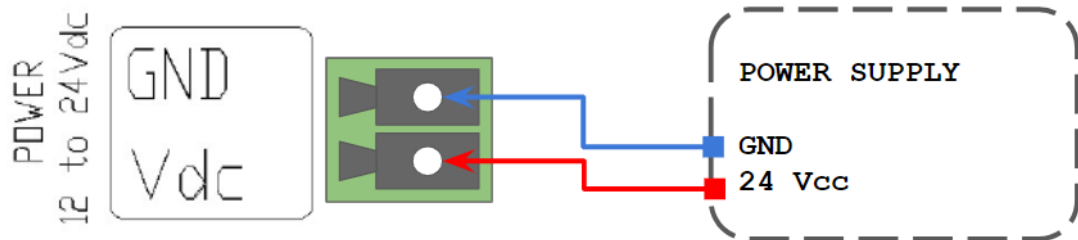

- Suggested power suppliers

Compact DIN rail power supply. Assembled on 35mm
DIN Rail:
-12Vdc / 24Vdc
-2.5A
-30W

Industrial Shields power supplies provide parallel operation, overvoltage protection, and overcurrent protection. There is a LED indicator for power status, the power supply is certified according to UL.



The standard, Part 1 of IEC 61010, sets the general safety requirements for the following types of electrical devices and their accessories, regardless of where use of the device is intended.

The equipment must be powered from an external power source in accordance with IEC 61010-1, whose output is MBTS and is limited in power according to section 9.4 of IEC 61010-1.

WARNING: Once the equipment is installed inside an electrical cabinet, the MTBS cables of the equipment must be separated from the dangerous voltage cables.

8. 10 I/Os serigraphy

8.1 Digital Module

8.1.1 Left Zone Connections

10 I/Os Connector	ESP32 Pin	Arduino Pin	Function
Q 0.9	G13	D9	Digital Output
Q 0.8	G12	D6	Digital Output
Q 0.7	G14	D5	Digital Output
Q 0.6	G27	D3	Digital Output
Q 0.5	G26	D2	Digital Output
Q 0.4	G25	A6	Digital Output
Q 0.3	G32	A3	Digital Output
Q 0.2	G15	A2	Digital Output
Q 0.1	G2	A1	Digital Output
Q 0.0	G4	A0	Digital Output

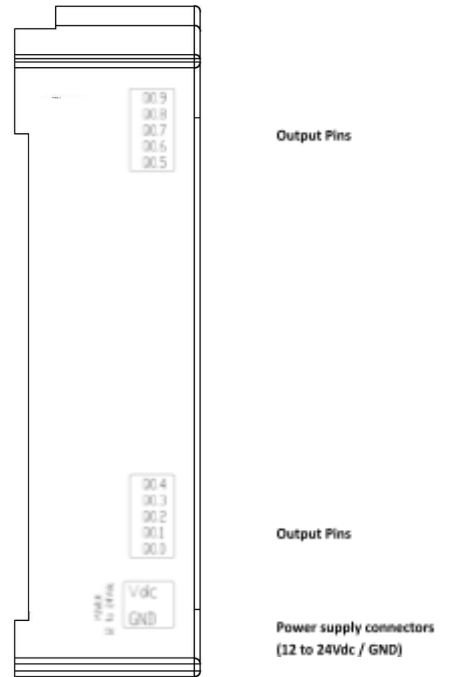

8.1.2 Right Zone Connections

10 I/Os Connector	ESP32 Pin	Arduino Pin	Function
I 0.9	G13	D9	Digital Input
I 0.8	G12	D6	Digital Input
I 0.7	G14	D5	Digital Input
I 0.6	G27	D3	Digital Input
I 0.5	G26	D2	Digital Input
GNDCOM2	-	-	Ground
I 0.4	G25	A6	Digital Input
I 0.3	G32	A3	Digital Input
I 0.2	G15	A2	Digital Input
I 0.1	G2	A1	Digital Input
I 0.0	G4	A0	Digital Input
GNDCOM1	-	-	Ground

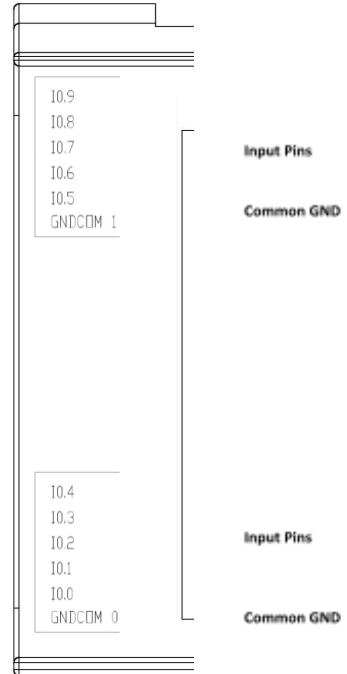

8.2 Relay Module

8.2.1 Left Zone Connections

10 I/Os Connector	ESP32 Pin	Arduino Pin	Function
GND 2	-	-	Ground
I 0.9	G13	D9	Digital Input
I 0.8	G12	D6	Digital Input
I 0.7	G14	D5	Digital Input
I 0.6	G27	D3	Digital Input
I 0.5	G26	D2	Digital Input
GND 1	-	-	Ground
I 0.4	G25	A6	Digital Input
I 0.3	G32	A3	Digital Input
I 0.2	G15	A2	Digital Input
I 0.1	G2	A1	Digital Input
I 0.0	G4	A0	Digital Input

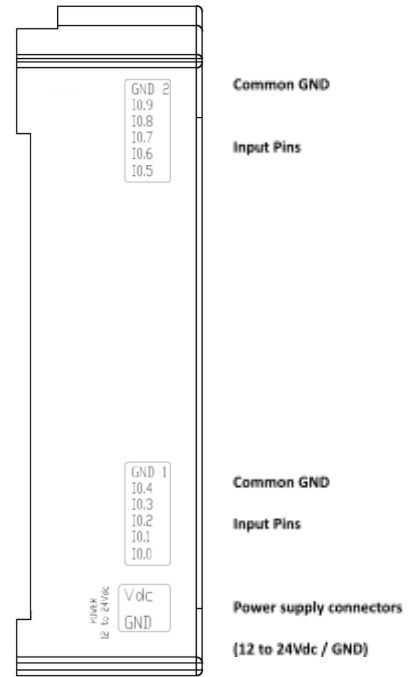

8.2.2 Right Zone Connections

10 I/Os Connector	ESP32 Pin	Arduino Pin	Function
R9	G13	D9	Relay Output
R8	G12	D6	Relay Output
R7	G14	D5	Relay Output
R6	G27	D3	Relay Output
R5	G26	D2	Relay Output
COM2	-	-	Ground
R4	G25	A6	Relay Output
R3	G32	A3	Relay Output
R2	G15	A2	Relay Output
R1	G2	A1	Relay Output
R0	G4	A0	Relay Output
COM1	-	-	Ground

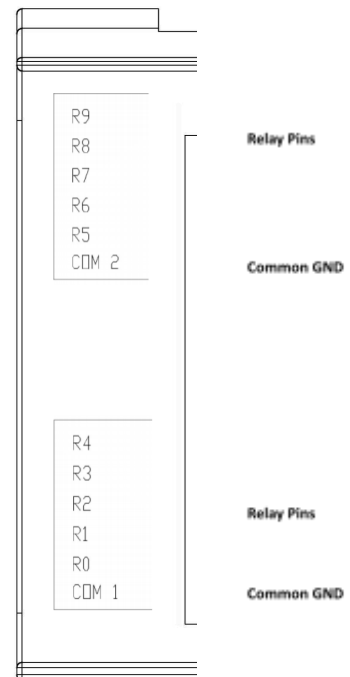



NOTE: In case you need to activate the reset button, it can be found by opening the top cover and accessing the white reset button of the ESP32 board integrated inside the enclosure.

NOTE: The LEDs positioned at the top of the PLC, which go from led 0 to 9 refer to both inputs and outputs.

For example, if you are using input I0.9, LED 9 on the top cover of the PLC will indicate the signal status of this input.

If output Q0.9 is being used, LED 9 on the upper cover of the PLC will indicate the status of the signal of this output.

An input and an output with the same nomenclature can never work at the same time (see jumper configuration on section 7).

9. Jumper configuration

9.1 General Jumper configuration. Digital Model

The 10 I/Os Digital Module provides 10 digital pins that can act as both input and output. However, they can only be working as one option at a time, so if their function is wished to be changed the jumpers must be adjusted. The board is divided in four zones for controlling the I/Os pins, the GND and the I/Os voltages. Also, the I/Os pins are divided in two blocks (0.9 to 0.5 and 0.4 to 0.0) that must be supplied with the same voltage. In order to configure the pins properly, all the zones with the same pin must be set correctly following the succeeding tables.



Warning!

If a pin is supplied with AC voltage, the entire block must be supplied with the same voltage type. In the same way, if a pin is supplied with DC voltage, the entire block must be supplied with DC voltage.

JUMPER ZONE 1					
LEFT			RIGHT		
1	2	3	1	2	3
IN - OUT			IN - OUT		

This jumper zone makes the selection between using the pins as **Inputs** or **Outputs**. There is a **Jumper Zone 1** with three pins on each side of the board. In the case of using the pins as **Inputs**, the jumper must be connected on the pins 1 and 2. Otherwise if the pin is wished to work as an **Output**, connect it on the pins 2 and 3. Both zones must be connected in the same way in order to work properly. See an example in [section 8.3](#).

JUMPER ZONE 2					
EXTERNAL GND			BOARD GND		
1	2	3	1	2	3

The jumper Zone 2 is for choosing between the board ground and an external one. If the board GND is chosen using the pins 2 and 3, the pin will work using the common ground of the device. In the case of using an external ground, set the jumper on the left side, connecting it to pins 1 and 2. See an example on [section 8.3](#).

JUMPER ZONE 3	
WITHOUT	WITH
230V	3.3 - 24V

These jumpers have to be set depending on the alimentation that the circuit is supplied with. If a power supply voltage of between 3.3V - 24V is being used, the switch must be connected as the **Jumper Zone 3** image. In the case of a 230V power supply, then the jumper must not be connected. See an example on [section 8.3](#).



Warning!

- **Outputs:** If the pin is working as output, its jumper of Zone 3 must be connected as the 3.3 - 24V option. It is a general nomenclature. In the case of the outputs, the output voltage will depend on the PLC External Power Supply (12 to 24Vdc).
- **Inputs:** If the pin is working as input, DO NOT connect the jumper of Zone 3 if you are using a power supply voltage of 230V as it will damage the device and could burn it.
- **WARNING:** The jumper Zone 3 configuration must be the same for all the jumper block (there are 2 jumper blocks: I/Os 0-4 or I/Os 5-9):
 - All the jumpers in the block if you configure it as Low Voltage Input or Low Voltage Output.
 - No jumper in the block if you configure it as High Voltage Input.

JUMPER ZONE 4					
5 V			24 V		
1	2	3	1	2	3

This jumper zone makes the choice between a 5V and 24V. The 24V option will be used in the case of using the pins as output as it will provide the same voltage as the input voltage of the PLC, while the 5V option will be reserved for the case of working as an input. Set the jumper on the 1st and 2nd position for the 5V choice or the 2nd and 3rd pin for the 24V alternative. See an example on [section 8.3](#).

9.2 General Jumper configuration. Relay Model

The 10 I/Os Relay Module provides 10 digital pins that can act as both input and output. However, they can only be working as one option at a time, so if their function is wished to be changed, the jumpers must be adjusted. The board is divided in four zones for controlling the I/Os pins, the GND and the I/Os voltages. Also, the I/Os pins are divided in two blocks (0.9 to 0.5 and 0.4 to 0.0) that must be supplied with the same voltage. In order to configure the pins properly, all the pins from the same zone must be set correctly following the succeeding tables.



Warning!

If a pin is supplied with AC voltage, the entire block must be supplied with the same voltage type. In the same way, if a pin is supplied with DC voltage, the entire block must be supplied with DC voltage.

JUMPER ZONE 1					
LEFT			RIGHT		
1	2	3	1	2	3
IN - OUT			IN - OUT		

This jumper zone makes the selection between using the pins as **Inputs** or **Outputs**. There is a **Jumper Zone 1** with three pins on each side of the board. In the case of using the pins as **Inputs**, the jumper must be connected on the pins 1 and 2. Otherwise if the pin is wished to work as an **Output**, connect it on the pins 2 and 3. Both zones must be connected in the same way in order to work properly. See an example in [section 8.3](#).

JUMPER ZONE 2					
EXTERNAL GND			BOARD GND		
1	2	3	1	2	3

The jumper Zone 2 is for choosing between the board ground and an external one. If the board GND is chosen using the pins 2 and 3, the pin will work using the common ground of the device. In the case of using an external ground, set the jumper on the left side, connecting it to pins 1 and 2. See an example on [section 8.3](#).



Warning!

- Inputs: If the pin is working as an input, it can only work using a voltage between 3.3V and 24V. Using a higher power supply voltage will damage the device and could burn it.
- Outputs: Do not connect it to a source higher than 230Vac.

9.3 I/Os Configuration examples

Input mode Digital Module

Low voltage

This is an example to configure 0.9 as an input with the range 3.3 - 24V current

This is an example to configure 0.9 as an input with the range 3.3 - 24V current

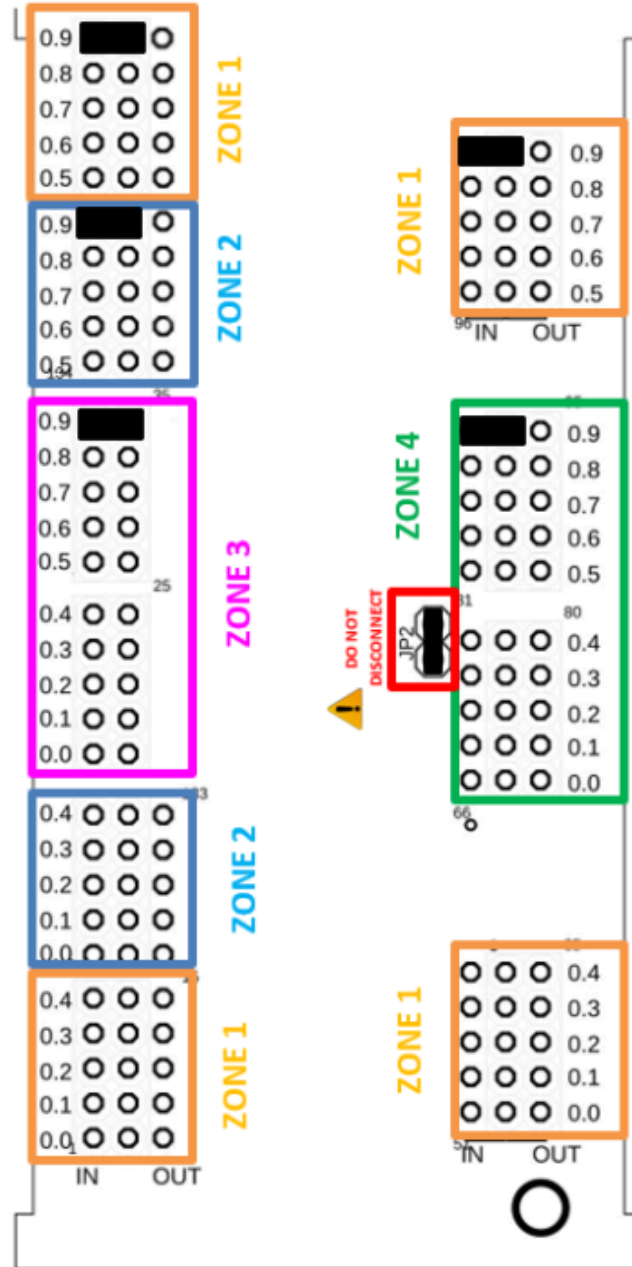

Input mode Digital Module

High voltage

This is an example to configure 0.9 as an input with the 230V current range.

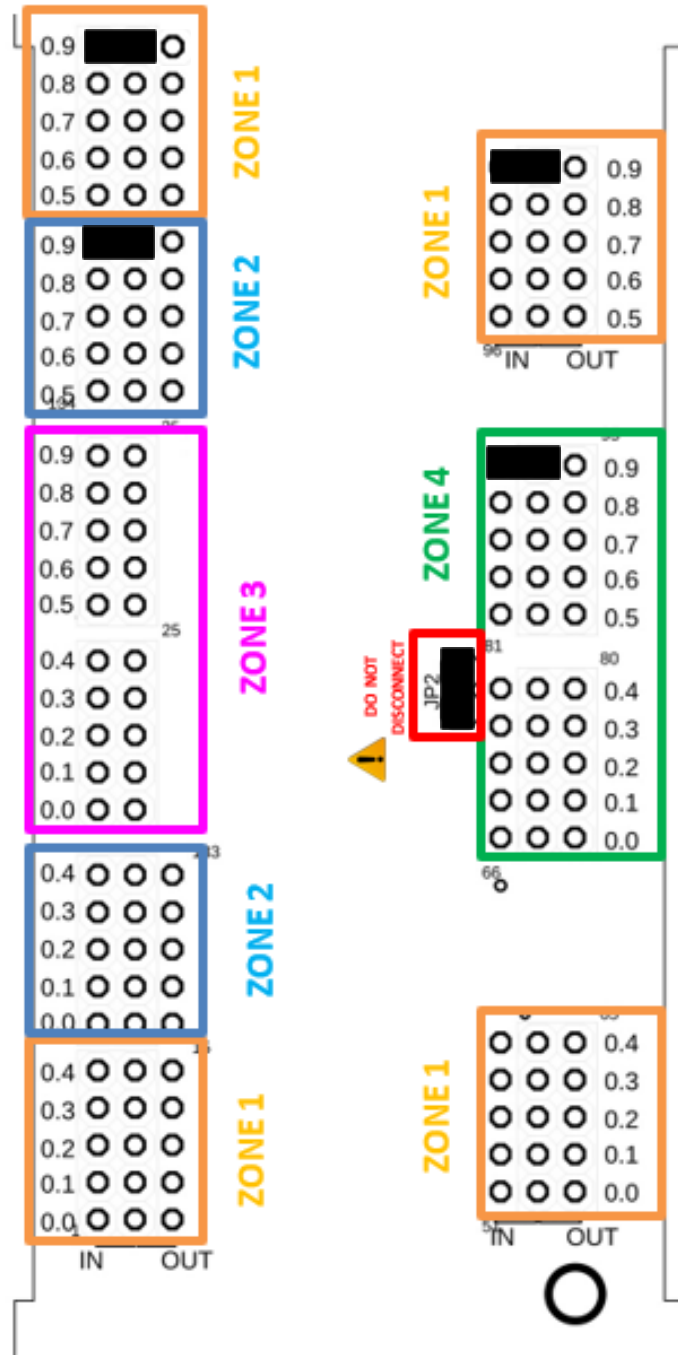

Output mode Digital Module

Low voltage

This is an example to configure 0.9 as an output with the 3.3 - 24V current range.

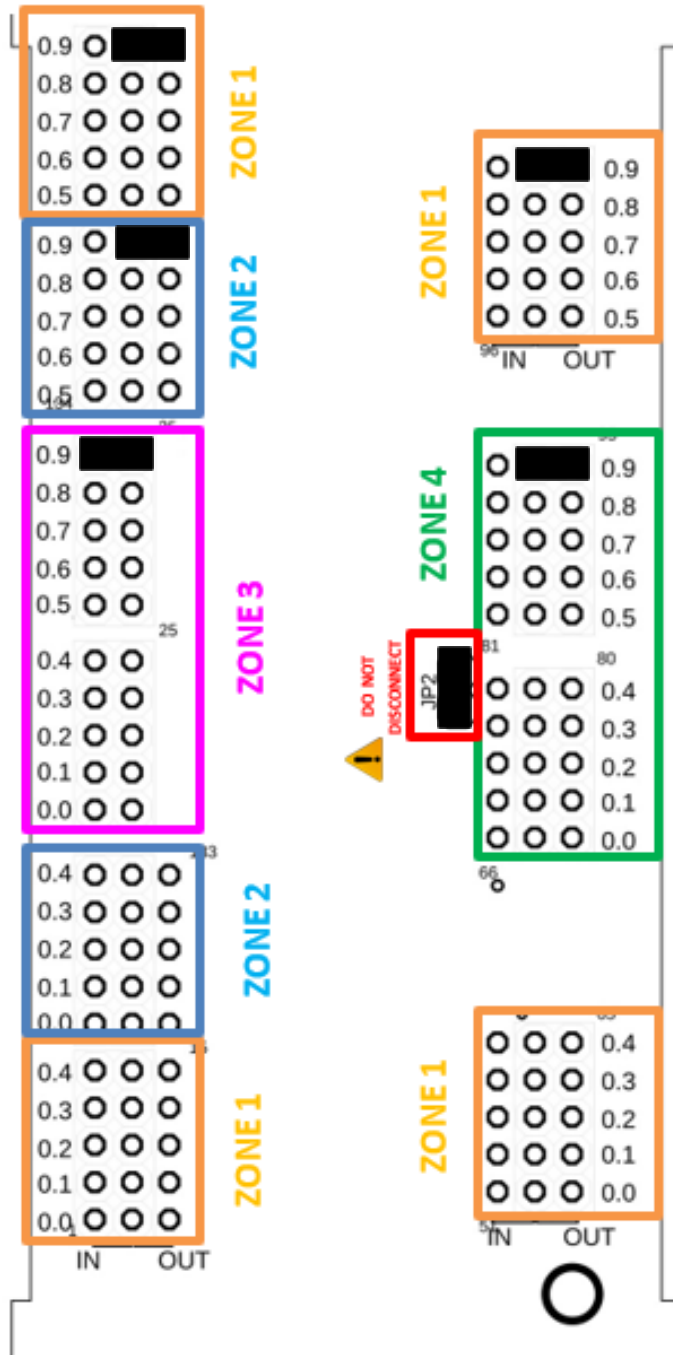

Input mode Relay Module

This is an example to configure 0.9 as an input.

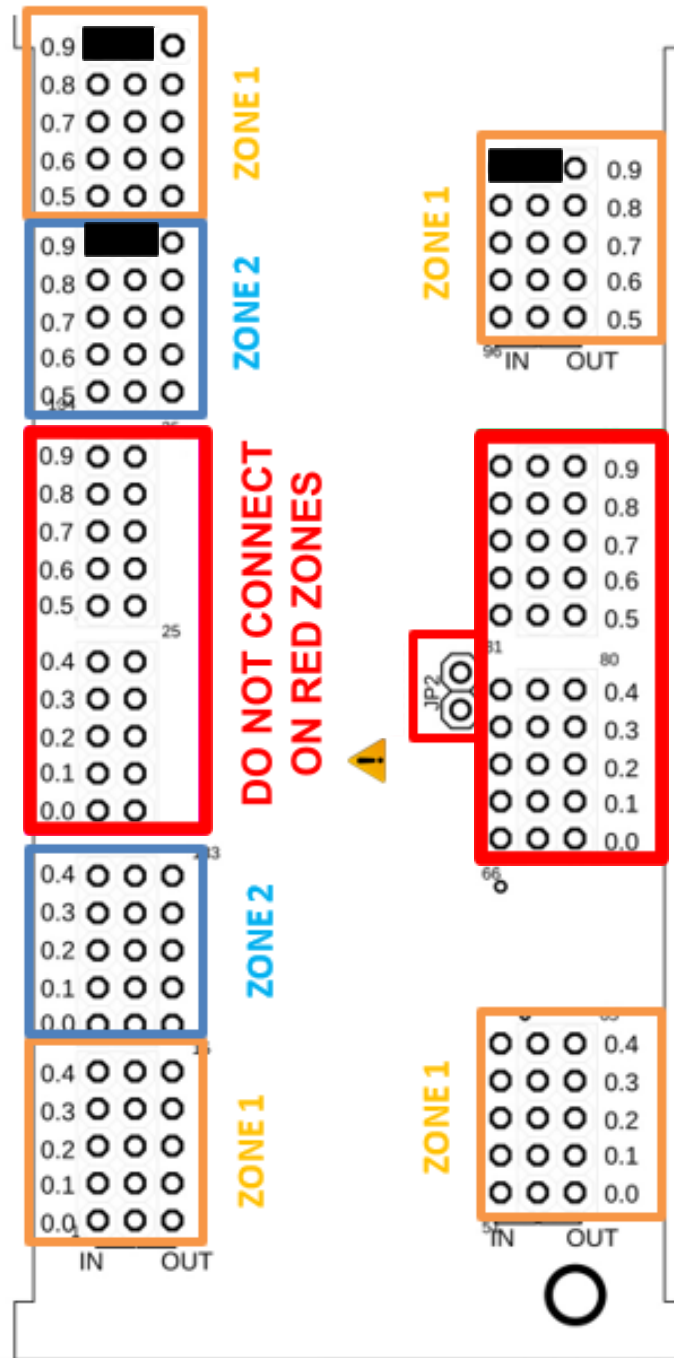

10. Software set up

Whether they are digital or relay, the inputs and outputs must be configured in the set up part of the code, like it is usually done in common Arduino boards. The function that must be used is `pinMode()`, like it is explained on the official Arduino website:

<https://www.arduino.cc/reference/en/language/functions/digital-io/pinmode/>

10.1 Example

If you want to configure an input, it can be done this way:

```
pinMode(I0_0, INPUT);
```

sketch_dec20a Arduino 1.8.13

Archivo Editar Programa Herramientas Ayuda

```
sketch_dec20a $
void setup() {
  // put your setup code here, to run once:
  pinMode(I0_0, INPUT);
  Serial.begin(9600);
}

void loop() {
  // put your main code here, to run repeatedly:
  Serial.println(digitalRead(I0_0));
}
```

If you want to configure an output, it can be done this way:

```
pinMode(R0_5, OUTPUT);
```

sketch_dec20b Arduino 1.8.13

Archivo Editar Programa Herramientas Ayuda

```
sketch_dec20b $
void setup() {
  // put your setup code here, to run once:
  pinMode(R0_5, OUTPUT);
  Serial.begin(9600);
}

void loop() {
  // put your main code here, to run repeatedly:
  digitalWrite(R0_5, HIGH);
  delay(1000);
  digitalWrite(R0_5, LOW);
}
```

You have to consider that the software configuration must match with the jumper configuration and that the same GPIO cannot be used as INPUT and OUTPUT at the same time, as it was previously explained.

11. I/Os Communications

11.1 RS485

The RS-485 is a half-duplex serial communication. The 10 I/Os PLC uses the MAX481CSA for the RS-485 communication. In the following image you can see the internal schematic of the PLC of the connection between microcontroller pins, the RS-485 chip and its outputs.

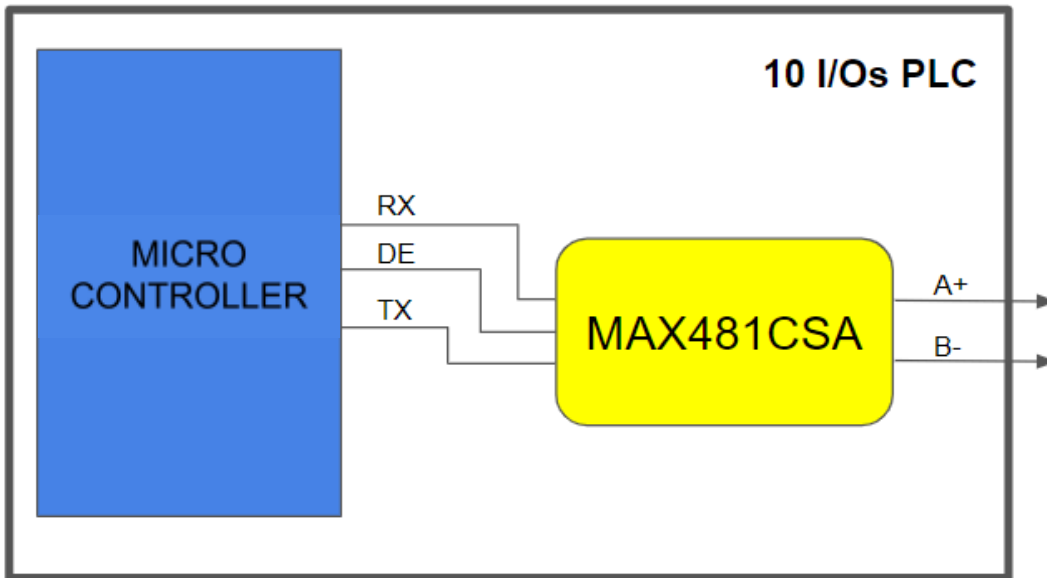

Using the boards of Industrial Shields, there is a library that simplifies the RS-485 implementation.

11.2 Ethernet

10 I/Os Ethernet port controller is based on w5500 IC, which is the IC compatible with Arduino Ethernet2 Shield libraries. All Ethernet shield Arduino libraries are compatible with the 10 I/Os. In the 10 I/Os PLC, W5500 IC communicates to the microcontroller board via SPI bus.

11.3 WiFi & BLE

The WiFi and Bluetooth integrated module consists of a single 2.4 GHz Wi-Fi and Bluetooth combo chip designed with the TSMC ultra-low-power 40 nm technology. It is designed to achieve the best power and RF performance, showing robustness, versatility and reliability in a wide variety of applications and power scenarios. Some applications are Generic Low-power IoT Sensor Hub, Generic Low-power IoT Data Loggers and Mesh Network. It is designed for Internet-of-Things (IoT) applications.

General Specifications

Wi-Fi

- 802.11 b/g/n
- 802.11 n (2.4 GHz), up to 150 Mbps

Bluetooth

- Bluetooth 4.2 BR/EDR BLE dual mode controller
- +12 dBm transmitting power
- NZIF receiver with -97 dBm BLE sensitivity

12. Typical Connections

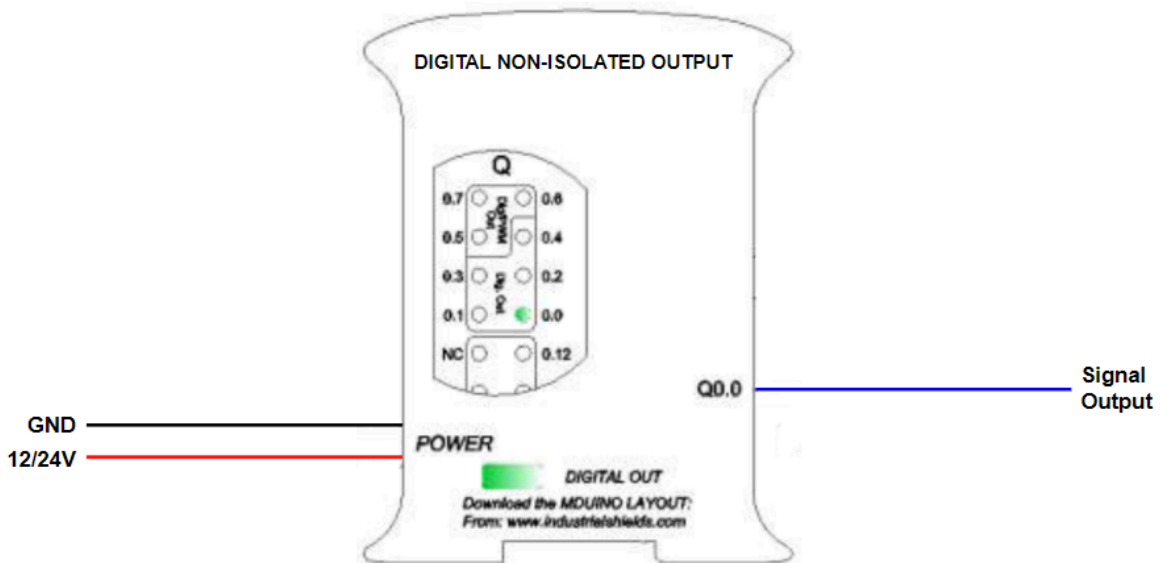
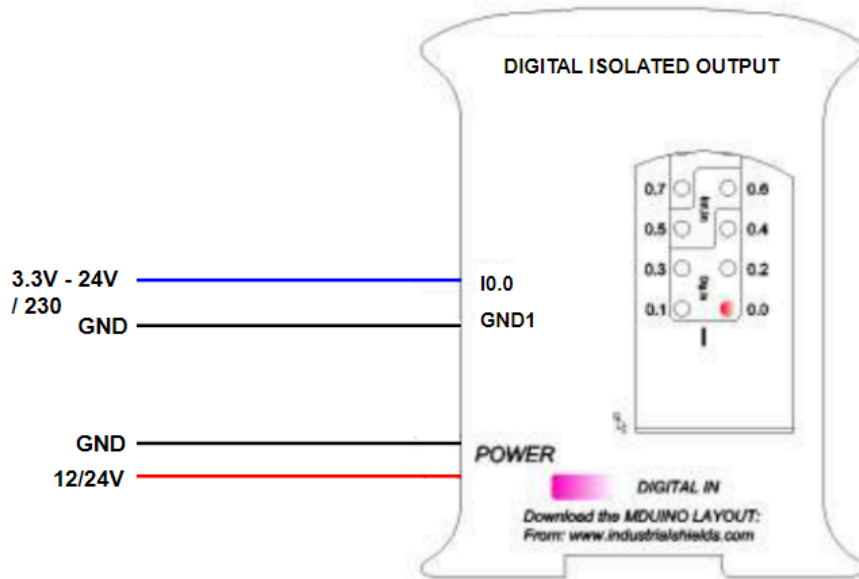

13. Connector details

The connector inside the PLCs that mounts on the PCB is MC 0,5/10-G-2,5 THT – 1963502 from Phoenix contact. MC0,5/10-G-2,5THT

For I/O and power supply there is a FK-MC 0,5/10-ST-2,5 - 1881406 connector from Phoenix contact. FK-MC 0,5/10-ST-2,5

Connection details:

Article reference	MC 0,5/10-G-2,5 THT
Height	8,1mm
Pitch	2,5mm
Dimension	22,5mm
Pin dimensions	0,8x0,8mm
Pin spacing	2,50mm



Article reference	FK-MC 0,5/10-ST-2,5
Rigid conduit section min.	0,14 mm ²
Rigid conduit section max.	0,5 mm ²
Flexible conduit section min.	0,14 mm ²
Flexible conduit section max.	0,5 mm ²
Conduit section AWG/kcmil min.	26
Conduit section AWG/kcmil max.	20

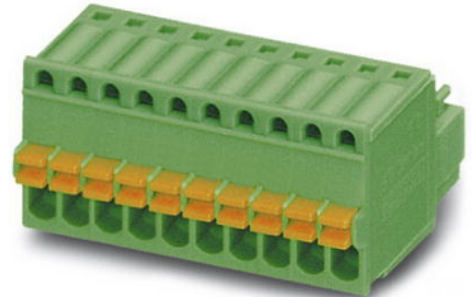

14. 10 I/Os Dimensions:

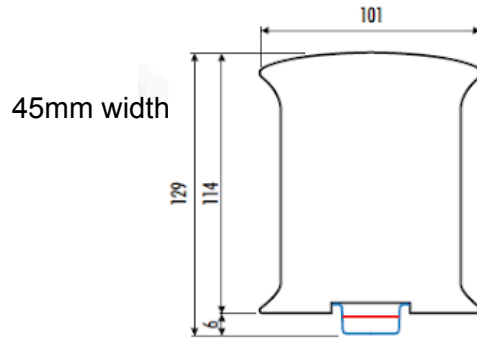

- DIN rail mounting:

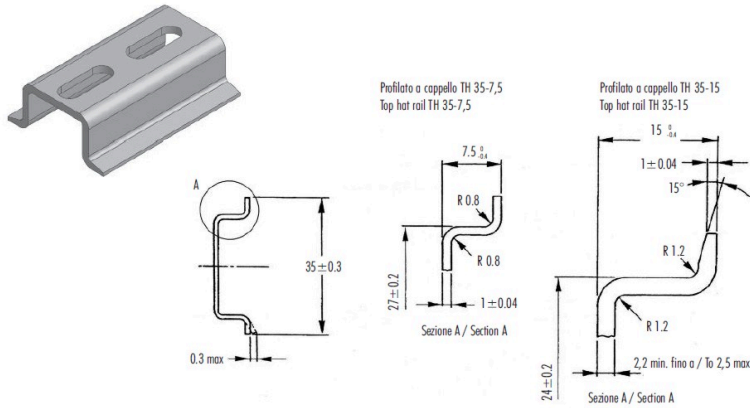

CARATTERISTICHE	METODO	UNITA' DI MISURA	BLENDE PC/ABS	
Mecchaniche	Resistenza a trazione allo scricchiolio	ASTM D638	MPa	68
	Resistenza a trazione a rottura	ASTM D638	MPa	48
	Allungamento a rottura	ASTM D638	%	59
	Modulo in flessione	ASTM D790	MPa	2894
Termiche	Prova Izod con intaglio	ISO 180/14	KJ/m ²	5.5
	Temp. di scricchiolio Visc. metodo B	ASTM D1525	°C	114
Fisiche	Temperatura Ricetta 1.81 MPa	ASTM D648	°C	97
	Peso specifico	ASTM D792	gr/cm ³	1.21
	Primo nella strappa	ASTM D955	%	0.4/0.6
	Heat Flow Index 260°C - 99N	ASTM D1238	gr/10'	11.1
	Comportamento alla fiamma	UL94	-	V-0 (0.8)
	Filo fusibile con 3.2 mm	IEC 6095.2.1	°C	960

Italtronic si riserva il diritto di modificare il materiale con cui realizza i propri prodotti senza obbligo di preavviso.

FEATURES	TEST METHOD	UNITS	BLENDE PC/ABS	
Mechanical test	Resistance to tensile stress at yield	ASTM D638	MPa	68
	Tensile strength	ASTM D638	MPa	48
	Ultimate elongation	ASTM D638	%	59
	Flexing modulus	ASTM D790	MPa	2894
Thermal test	Izod test method	ISO 180/14	KJ/m ²	5.5
	Visc softening temperature method B	ASTM D1525	°C	114
Physical test	Reheating temperature 1.81 MPa	ASTM D648	°C	97
	Specific gravity	ASTM D792	gr/cm ³	1.21
	Moist shrinkage	ASTM D955	%	0.4/0.6
Flame test	Heat Flow Index 260°C - 99N	ASTM D1238	gr/10'	11.1
	Self extinguisher (thickness in mm)	UL94	-	V-0 (0.8)
	Insulation thread 3.2 mm	IEC 6095.2.1	°C	960

Italtronic can operate any change of the materials without being obliged to forewarn.



15. Installation and Maintenance

Notes for installation:

- The installation position should be free from the following: dust or oil smoke, conductive dust, corrosive or flammable gas, high temperature, condensation, and rain.
- Besides, vibration and impact also affect the PLC normal operation and shorten its lifespan; electric shock, fire or misact also damages the product. During drilling or wiring, prevent the metal particles or wire segments from falling into the PLC casing, which may cause fire, fault or misact.
- After the PLC installation, clean the ventilation duct to prevent blocking, which may cause bad ventilation, or even fire, faults or misact.
- Do not online connect, plug or unplug cables, which are apt to cause electric shock or damage the circuit. Installation and wire connection must be firm and reliable. Poor connection could cause a misact.
- Use shielded twisted pairs for the I/O of high frequency signal and analog signal to improve system IMS.

The installation environment should be free from dust, oil smoke, conductive particles, corrosive or flammable gases, high temperature, condensation, and rain.

Besides, vibration and impact also affect the PLC normal operation and shorten its lifespan. It is recommended to install the PLC, together with the matching switches and contactors, in a dedicated electric cabinet and keep the cabinet ventilated. If the location has high ambient temperature or heat generating equipment nearby, install forced convection devices on top or sides of the cabinet to avoid over-temperature. During drilling or wiring, prevent the metal particles or wire segments from falling into the PLC casing, which may cause fire, fault or misact. After the PLC installation, clean the ventilation duct to prevent blocking, which may cause bad ventilation, or even fire, faults or misact.

The only way to disconnect the equipment from the electrical network is by removing the connectors that feed the equipment. Once installed in the electrical cabinet it is very important to ensure the power connectors for proper operation.

Separate the 10 I/Os MODULE from heat, high voltage and electrical noise:

Always separate the devices that generate high voltage and high electrical noise from the 10 I/Os Module. When configuring the layout of the 10 I/Os Module inside your panel, consider the heat-generating devices and locate the electronic-type devices in the cooler areas of your cabinet. Reducing the exposure to a high-temperature environment will extend the operating life of any electronic device. Also consider the routing of the wiring for the devices in the electric cabinet. Avoid placing low-voltage signal wires and communications cables in the same tray with AC power wiring and high energy, rapidly switched DC wiring.

Provide adequate clearance for cooling and wiring 10 I/Os Module. Is designed for natural convection cooling. For proper cooling, you must provide a clearance of at least 25 cm above and below the devices. Also, allow at least 25 cm of depth between the front of the modules and the inside of the enclosure.

Notes for maintenance:

A well-planned and executed maintenance program is essential to the satisfactory operation of solid-state electrical equipment. The kind and frequency of the maintenance operation will vary with the kind and complexity of the equipment as well as with the nature of the operating conditions. Maintenance recommendations of the manufacturer or appropriate product standards should be followed.

The following factors should be considered when formulating a maintenance program:

- Maintenance must be performed by qualified personnel familiar with the construction, operation, and hazards involved with the control.
- Maintenance should be performed with the control out of operation and disconnected from all sources of power.
- Care should be taken when servicing electrostatic sensitive components. The manufacturer's recommendations for these components should be followed.
- Ventilation passages should be kept open. If the equipment depends upon auxiliary cooling, e.g., air, water, or oil, periodic inspection (with filter replacement when necessary) should be made of these systems.
- The means employed for grounding or insulating the equipment from ground should be checked to assure its integrity.
- Accumulations of dust and dirt on all parts, including on semiconductor heat sinks, should be removed according to the manufacturer's instructions, if provided; otherwise, the manufacturer should be consulted. Care must be taken to avoid damaging any delicate components and to avoid displacing dust, dirt, or debris in a way that permits it to enter or settle into parts of the control equipment.
- Enclosures should be inspected for evidence of deterioration. Accumulated dust and dirt should be removed from the top of the enclosures before opening doors or removing covers.
- Certain hazardous materials removed as part of maintenance or repair procedure (e.g., polychlorinated biphenyls (PCBs) found in some liquid filled capacitors) must be disposed of as described in Federal regulations.

Safety rules for maintenance personnel

Consider the following steps to follow. A false manoeuvre could be the cause of an accident or material damage.

Do not disassemble or modify the modules. This could lead to breakdowns or malfunctions and could lead to injuries or fire.

- All types of radio communication devices, including mobile phones and personal handy-phone systems (PHS), must be kept more than **25cm** away from the PLC in all directions. Failure to observe this precaution exposes malfunctions caused by excess temperature.
- Disconnect the external power supply of the system (on all phases) before connecting or disconnecting a module. Failure to observe this precaution may cause faults or malfunctions of the module.

- Tighten the screws of the terminal ports and the screws of the connectors within the prescribed tightening torque. Insufficient tightening can lead to loose parts or wires and cause malfunctions. Excessive tightening can damage the screws and / or the module, with the risk of falling, short circuits and malfunctions.
- Before handling a module, dispose of the electrostatic charge accumulated by the human body by touching a suitable conductive object. Failure to observe this precaution may cause faults or malfunctions of the module.

Repair note:

If the equipment is suitable to be repaired, it must be verified that the equipment remains in a safe state after repair.

16. Revision Table

Revision Number	Date	Changes
0	21/09/2020	First implementation
1	03/06/2021	Section 1 modified
2	20/12/2021	Section 9 added
3	25/03/2022	Micro USB warning added
4	12/05/2022	Section 1 modified
5	15/06/2023	New 10 IOs implementation
6	29/08/2024	Jumper section updated
7	26/09/2024	Added section 3.3 ("Isolation Precautions")
8	11/11/2024	Section 5 modified.

About Industrial Shields:

Direction: Camí del grau, 25

Zip/Postal Code: 08272

City: Sant Fruitós de Bages (Barcelona)

Country: Spain

Telephone: (+34) 938 760 191 / (+34) 635 693 611

Mail: industrialshields@industrialshields.com