



INDUSTRIAL SHIELDS

## M-DUINO DALI PLC ARDUINO FAMILY

M-DUINO DALI PLC ARDUINO  
FAMILY



# PLC M-Duino DALI Family User Guide

**Revised December 2024**

## Preface

This User Guide has been implemented by Boot & Work, S.L. working under the name Industrial Shields.

### Purpose of the manual

The information contained in this manual can be used as a reference to operating, to functions, and to the technical data of the signal modules, power supply modules and interface modules.

### Intended Audience

This User Guide is intended for the following audience:

- Persons in charge of introducing automation devices.
- Persons who design automation systems.
- Persons who install or connect automation devices.
- Persons who manage working automation installation.



#### Warnings:

- Unused pins should not be connected. Ignoring the directive may damage the controller.
- Improper use of this product may severely damage the controller.
- Refer to the controller's User Guide regarding wiring considerations.
- Before using this product, it is the responsibility of the user to read the product's User Guide and all accompanying documentation.
- Maintenance must be performed by qualified personnel familiarised with the construction, operation, and hazards involved with the control.
- Maintenance should be performed with the control out of operation and disconnected from all sources of power.
- Care should be taken when servicing electrostatic sensitive components. The manufacturer's recommendations for these components should be followed.

- The M-Duino DALI Family PLCs are Open Type Controllers. It is required that you install the M-Duino DALI PLC in a housing, cabinet, or electric control room. Entry to the housing, cabinet, or electric control room should be limited to authorised personnel. Failure to follow these installation requirements could result in severe personal injury and/or property damage. Always follow these requirements when installing M-Duino family PLCs.
- In case of installation or maintenance of the M-Duino please follow the instructions marked in the Installation and Maintenance section.
- Do not disconnect equipment when a flammable or combustible atmosphere is present. Disconnection of equipment when a flammable or combustible atmosphere is present may cause a fire or explosion which could result in death, serious injury and/or property damage.



### Avertissements

- Les broches non utilisées ne doivent pas être connectées. Ignorer la directive peut endommager le contrôleur.
- Une utilisation incorrecte de ce produit peut endommager gravement le contrôleur.
- Reportez-vous au Guide de l'utilisateur du contrôleur pour les considérations de câblage.
- Avant d'utiliser ce produit, il incombe à l'utilisateur de lire le Guide de l'utilisateur du produit et la documentation qui l'accompagne.
- La maintenance doit être effectuée par personnel qualifié familiarisé avec la fabrication, le fonctionnement et les dangers liés au contrôleur.
- La maintenance doit être effectuée avec l'équipement hors service et déconnectée de toutes les sources d'alimentation.
- Faites attention lors de l'entretien des composants sensibles à l'électricité statique. Les recommandations du fabricant pour ces composants doivent être suivies.
- Les automates de la famille M-Duino sont des contrôleurs de type ouvert. Il est nécessaire d'installer l'automate M-Duino dans un boîtier, une armoire ou une salle de contrôle électrique. L'accès au boîtier, à l'armoire ou à la salle de commande électrique doit être limité au personnel autorisé. Le non-respect de ces exigences d'installation peut entraîner des blessures graves et/ou des dommages matériels importants. Respectez toujours ces exigences lors de l'installation des automates de la famille M-Duino.
- En cas d'installation ou de maintenance du M-Duino, veuillez suivre les instructions indiquées dans la section Installation et Maintenance.
- Ne débranchez pas l'équipement en présence d'une atmosphère inflammable ou combustible. La déconnexion de l'équipement en présence d'une atmosphère inflammable ou combustible peut provoquer un incendie ou une explosion pouvant entraîner la mort, des blessures graves et/ou des dommages matériels.

## Application Considerations and Warranty

### Read and understand this manual

Please read and understand this manual before using the product. Please consult your comments or questions to Industrial Shields before using the product.

### Application Consideration

THE PRODUCTS CONTAINED IN THIS DOCUMENT ARE NOT SAFETY RATED. THEY SHOULD NOT BE RELIED UPON AS A SAFETY COMPONENT OR PROTECTIVE DEVICE FOR ENSURING SAFETY OF PERSONS, AS THEY ARE NOT RATED OR DESIGNED FOR SUCH PURPOSES.

Please know and observe all prohibitions of use applicable to the products.

FOR AN APPLICATION INVOLVING SERIOUS RISK TO LIFE OR PROPERTY WITHOUT ENSURING THAT THE SYSTEM AS A WHOLE HAS BEEN DESIGNED TO ADDRESS THE RISKS, NEVER USE THE INDUSTRIAL SHIELDS PRODUCTS.

NEVER USE THE INDUSTRIAL SHIELDS PRODUCTS BEFORE THEY ARE PROPERLY RATED AND INSTALLED FOR THE INTENDED USE WITHIN THE OVERALL EQUIPMENT OR SYSTEM.

Industrial Shields shall not be responsible for conformity with any codes, regulations or standards that apply to the combination of products in the customer's application or use of the product.

The following are some examples of applications for which particular attention must be given. This is not intended to be an exhaustive list of all possible uses of the products, nor is it intended to imply that the uses may be suitable for the products:

- Systems, machines, and equipment that could present a risk to life or property.
- Nuclear energy control systems, combustion systems, railroad systems, aviation systems, medical equipment, amusement machines, vehicles, safety equipment, and installation subject to separate industry or government regulations.
- Outdoor use, uses involving potential chemical contamination or electrical interference, or conditions or uses not described in this document.

At the customer's request, INDUSTRIAL SHIELDS will provide applicable third party certification documents identifying ratings and limitations of use that apply to the products. This information by itself is not sufficient for a complete determination of the suitability of the products in combination with the system, machine, end product, or other application or use.

## Intended use of Industrial Shields products

### Consider the following:

Industrial Shields products should only be used for the cases of application foreseen in the catalogue and the associated technical documentation. If third-party products and components are used, they must have been recommended or approved by Industrial Shields.

The correct and safe operation of the products requires that your transport, storage, installation, assembly, operation and maintenance have been carried out in a correct manner. It must respect the permissible ambient conditions. You should also follow the indications and warnings that appear in the associated documentation.

The product / system dealt with in this documentation should only be handled or manipulated by qualified personnel for the task entrusted and observing what is indicated in the documentation corresponding to it, particularly the safety instructions and warnings included in it. Due to their training and experience, qualified personnel are in a position to recognize risks resulting from the handling or manipulation of such products / systems and to avoid possible hazards.

## Disclaimers

### Weights and Dimensions

Dimensions and weights are nominal and they are not used for manufacturing purposes, even when tolerances are shown.

### Performance Data

The performance data given in this manual is provided as a guide for the user in determining suitability and does not constitute a warranty. It may represent the result of INDUSTRIAL SHIELDS's test conditions, and the users must correlate it to actual application requirements. Actual performance is subject to the INDUSTRIAL SHIELDS Warranty and Limitations of Liability.

### Errors and Omissions

The information in this document has been carefully checked and is believed to be accurate; however, no responsibility is assumed for clerical, typographical, or proofreading errors, or omissions.

### Residual Risks

The control and drive components of an Industrial Shields PLC are approved for industrial and commercial use in industrial line supplies. Their use in public line supplies requires a different configuration and/or additional measures. These components may only be operated in closed housings or in higher-level control cabinets with protective covers that are closed, and

when all of the protective devices are used. These components may only be handled by qualified and trained technical personnel who are knowledgeable and observe all of the safety information and instructions on the components and in the associated technical user documentation. When carrying out a risk assessment of a machine in accordance with the EU Machinery Directive, the machine manufacturer must consider the following residual risks associated with the control and drive components of a PDS.

1. Unintentional movements of driven machine components during commissioning, operation, maintenance, and repairs caused by, for example: – Hardware defects and/or software errors in the sensors, controllers, actuators, and connection technology – Response times of the controller and drive – Operating and/or ambient conditions not within the scope of the specification – Condensation / conductive contamination – Parameterization, programming, cabling, and installation errors – Use of radio devices / cellular phones in the immediate vicinity of the controller – External influences / damage.
2. Exceptional temperatures as well as emissions of noise, particles, or gas caused by, for example: – Component malfunctions – Software errors – Operating and/or ambient conditions not within the scope of the specification – External influences / damage.
3. Hazardous shock voltages caused by, for example: – Component malfunctions – Influence of electrostatic charging – Induction of voltages in moving motors – Operating and/or ambient conditions not within the scope of the specification – Condensation / conductive contamination – External influences / damage
4. Electrical, magnetic and electromagnetic fields generated in operation that can pose a risk to people with a pacemaker, implants or metal replacement joints, etc. if they are too close.
5. Release of environmental pollutants or emissions as a result of improper operation of the system and/or failure to dispose of components safely and correctly.

## Warranty and Limitations of Liability

### Warranty

Industrial Shields's exclusive warranty is that the products are free from defects in materials and workmanship for a period of one year (or other period if specified) from date of sale by Industrial Shields.

INDUSTRIAL SHIELDS MAKES NO REPRESENTATION OR WARRANTY, EXPRESSED OR IMPLIED, REGARDING MERCHANTABILITY, NON-INFRINGEMENT, OR FITNESS FOR PARTICULAR PURPOSE OF THE PRODUCTS. ANY BUYER OR USER ACKNOWLEDGES THAT THE BUYER OR USER ALONE HAS DETERMINED THAT THE PRODUCTS WILL SUITABLY MEET THE REQUIREMENTS OF THEIR INTENDED USE. INDUSTRIAL SHIELDS DISCLAIMS ALL OTHER WARRANTIES, EXPRESS OR IMPLIED

## Limitations of Liability

INDUSTRIAL SHIELDS SHALL NOT BE RESPONSIBLE FOR SPECIAL, INDIRECT, OR CONSEQUENTIAL DAMAGES, LOSS OF PROFITS OR COMERCIAL LOSS IN ANY WAY CONNECTED WITH THE PRODUCTS, WHETHER SUCH CLAIM IS BASED ON CONTRACT, WARRANTY, NEGLIGENCE, OR STRICT LIABILITY.

IN NO EVENT SHALL INDUSTRIAL SHIELDS BE RESPONSIBLE FOR WARRANTY, REPAIR OR OTHER CLAIMS REGARDING THE PRODUCTS UNLESS INDUSTRIAL SHIELDS'S ANALYSIS CONFIRMS THAT THE PRODUCTS WERE PROPERLY HANDLED, STORED, INSTALLED, AND MAINTAINED AND NOT SUBJECT TO CONTAMINATION, ABUSE, MISUSE, OR INAPPROPRIATE MODIFICATION OR REPAIR.

## ETL Listing Mark-Direct Imprint information

### Recognized Component ETL Classified



#### Conforms to:

UL Std. 61010-1  
UL Std. 61010-2-201  
Cert. To CSA Std. C22.2 No. 61010-1  
Cert. To CSA Std. C22.2 No.61010-2-201

#### Place for control

number:  
5016476



# Table of Contents

<b>1 General Description M-DUINO DALI product</b>	<b>10</b>
1.1 Zone - Nomenclature	10
1.2 Reference table	11
1.3 Zones Table	12
1.4 A Zone Features	13
1.5 Mechanical dimensions and weights	13
1.6 General Features	14
1.7 Power consumption of the M-Duino DALI Family PLCs	16
<b>2 Technical Specifications:</b>	<b>17</b>
2.1 General Specifications:	17
2.2 Performance Specification:	17
2.3 Symbology	18
<b>3 Precautions</b>	<b>19</b>
3.1 Arduino Board	19
3.2 Intended Audience	19
3.3 General Precautions	19
3.4 Isolation Precautions	19
<b>4 M-Duino Pinout</b>	<b>20</b>
<b>5 Serigraphy</b>	<b>21</b>
5.1 A Zone connection (Communications)	21
5.2 Analog/Digital Zone connection (I/Os)	23
5.3 Relay Zone connection (I/Os)	24
5.4 Interrupt equivalence table	25
<b>6 Software interface</b>	<b>26</b>
<b>7 How to connect PLC Arduino to PC</b>	<b>29</b>
<b>8 How to connect PLC to power supply</b>	<b>30</b>
<b>9 Switch configuration</b>	<b>31</b>
9.1 A Zone: Communications	31
9.2 Digital/Analogic Shield Switches	33
9.3 Relay Shield Switches	34
<b>10 M-Duino Arduino I/Os 5V pins</b>	<b>35</b>
10.1 I2C pins – SDA/SCL	35
10.2 Serial 0 – RX0/TX0	36
10.3 SPI – MISO/MOSI/SCK	36
10.4 Pin 2/Pin 3	36
<b>11 A Zone Features: Communications &amp; RTC &amp; uSD</b>	<b>37</b>

11.1 RS-232	37
11.2 RS-485	37
11.3 I2C	38
11.4 SPI	38
11.5 TTL	38
11.6 Ethernet	38
11.7 RTC	39
11.8 uSD	39
<b>12 Examples</b>	<b>41</b>
12.1 Lighting Protocol DALI in a PLC Arduino	41
12.2 How to work with DALI Arduino Library and an industrial PLC	41
<b>13 Instructions for interconnection between Industrial Shields controllers</b>	<b>42</b>
13.1 RS-232 Communication:	42
13.2 RS-485 Communication:	42
13.2.1 Half Duplex	42
13.2.2 Full Duplex	42
13.3 Ethernet	43
<b>14 Digital inputs threshold detection</b>	<b>43</b>
<b>15 I/O technical details</b>	<b>44</b>
<b>16 Typical Connections</b>	<b>46</b>
<b>17 Connector details</b>	<b>51</b>
<b>18 DIN Rail mounting</b>	<b>54</b>
<b>19 Installation and Maintenance</b>	<b>55</b>
<b>20 Revision Table</b>	<b>58</b>



INDUSTRIAL SHIELDS

## 1 General Description M-DUINO DALI product

### 1.1 Zone - Nomenclature

The nomenclature shown in this point will be used in the whole User Guide, so it is important to understand this nomenclature.

The nomenclature to differentiate the zones is based on the Alphabet, being A the shield from below and D the shield from above. Having a B and a C in the middle of them.

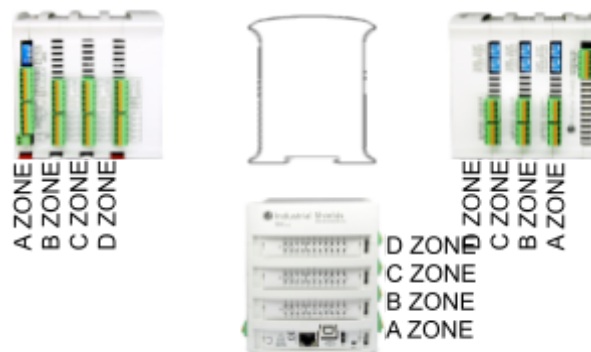

- The inputs in zone B are named I0.X, being X any number suitable in the Shield. Outputs are named as Q0.X and relays as R0.X.
- The inputs in zone C are named I1.X, being X any number suitable in the Shield. Outputs are named as Q1.X and relays as R1.X.
- The inputs in zone D are named I2.X, being X any number suitable in the Shield. Outputs are named as Q2.X and relays as R2.X.

## 1.2 Reference table

Reference Table	
Model	Reference
<b>PLC M-Duino General Family</b>	
M-Duino PLC Arduino Ethernet & DALI 19R I/Os Analog / Digital Plus	004001000100
M-Duino PLC Arduino Ethernet & DALI 21 I/Os Analog / Digital Plus	004001000200
M-Duino PLC Arduino Ethernet & DALI 38AR I/Os Analog / Digital Plus	004001000700
M-Duino PLC Arduino Ethernet & DALI 38R I/Os Analog / Digital Plus	004001000300
M-Duino PLC Arduino Ethernet & DALI 42 I/Os Analog / Digital Plus	004001000400
M-Duino PLC Arduino Ethernet & DALI 50RRA I/Os Analog / Digital Plus	004001000900
M-Duino PLC Arduino Ethernet & DALI 53ARR I/Os Analog / Digital Plus	004001001000
M-Duino PLC Arduino Ethernet & DALI 54ARA I/Os Analog / Digital Plus	004001001100
M-Duino PLC Arduino Ethernet & DALI 57AAR I/Os Analog / Digital Plus	004001000800
M-Duino PLC Arduino Ethernet & DALI 57R I/Os Analog / Digital Plus	004001000500
M-Duino PLC Arduino Ethernet & DALI 58 I/Os Analog / Digital Plus	004001000600

To find the reference of your M-Duino DALI PLC, check the arrow in the picture below. In the example, the reference is:

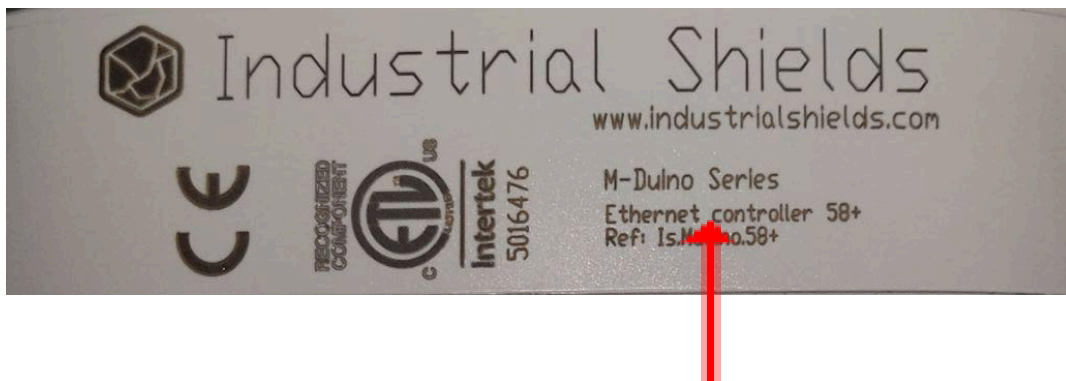

### 1.3 Zones Table

Model	Zones Table			
	Zone A	Zone B	Zone C	Zone D
M-Duino DALI PLC 19R+	✓	Relay	-	-
M-Duino DALIE PLC 21+	✓	Analog / Digital	-	-
M-Duino DALI PLC 38AR+	✓	Analog / Digital	Relay	-
M-Duino DALI PLC 38R+	✓	Relay	Relay	-
M-Duino DALI PLC 42+	✓	Analog / Digital	Analog / Digital	-
M-Duino DALI PLC 50RRA+	✓	Relay	Relay	Analog / Digital
M-Duino DALI PLC 53ARR+	✓	Analog / Digital	Relay	Relay
M-Duino DALI PLC 54ARA+	✓	Analog / Digital	Relay	Analog / Digital
M-Duino DALI PLC 57AAR+	✓	Analog / Digital	Analog / Digital	Relay
M-Duino DALI PLC 57R+	✓	Relay	Relay	Relay
M-Duino DALI PLC 58+	✓	Analog / Digital	Analog / Digital	Analog / Digital

The distribution of the different features that provide the M-Duino DALI PLC Family is the following one:

Shield	B Zone	C Zone	D Zone
Analog Shield	<p>13 Inputs (13 Digital Inputs, 6 of which can work as Analog Input)</p> <p>8 Outputs (8 Digital Outputs, 3 of which can work as Analog Output)</p>	<p>11 Inputs (11 Digital Inputs, 6 of which can work as Analog Input)</p> <p>8 Outputs (8 Digital Outputs, 3 of which can work as Analog Output)</p>	<p>10 Inputs (10 Digital Inputs, 4 of which can work as Analog Input)</p> <p>6 Outputs (6 Digital Outputs, 2 of which can work as Analog Outputs)</p>
Relay Shield	<p>6 inputs (6 Digital Inputs, 4 of which can work as Analog Input)</p> <p>3 Outputs (3 Digital Outputs, 3 of which can work as Analog Output)</p> <p>8 Relays</p>	<p>4 inputs (4 Digital Inputs, 4 of which can work as Analog Input)</p> <p>3 Outputs (3 Digital Outputs, 3 of which can work as Analog Output)</p> <p>8 Relays</p>	<p>6 inputs (6 Digital Inputs, 4 of which can work as Analog Input)</p> <p>2 Outputs (2 Digital Outputs, 2 of which can work as Analog Output)</p> <p>7 Relays</p>

### 1.4 A Zone Features

Shield	A Zone
Communication Shield	(1x) Ethernet (1x) USB (1x) I2C (1x) TTL (1x) RS-232 (1x) HALF/FULL Duplex RS-485 (1x) SPI external Port (1x) RTC (1x) uSD Socket

### 1.5 Mechanical dimensions and weights

Model	Measures Table			
	Height (mm)	Width (mm)	Depth (mm)	Max weight (g)
M-Duino DALI PLC 19R+	119.5	70.1	101	394
M-Duino DALIE PLC 21+	119.5	70.1	101	394
M-Duino DALI PLC 38AR+	119.5	94.7	101	504
M-Duino DALI PLC 38R+	119.5	94.7	101	504
M-Duino DALI PLC 42+	119.5	94.7	101	504
M-Duino DALI PLC 50RRA+	119.5	119.3	101	614
M-Duino DALI PLC 53ARR+	119.5	119.3	101	614
M-Duino DALI PLC 54ARA+	119.5	119.3	101	614
M-Duino DALI PLC 57AAR+	119.5	119.3	101	614
M-Duino DALI PLC 57R+	119.5	119.3	101	614
M-Duino DALI PLC 58+	119.5	119.3	101	614

## 1.6 General Features

CONNECTABLE PLC ARDUINO 24Vcc M-DUINO		
MODEL TYPE	Controller General Specifications	Information
<b>Input Voltage</b>	12 to 24Vdc ===	Fuse protection (2.5A) Polarity protection
<b>Input rated voltage</b>	24Vdc ===	
<b>Rated Power</b>	30W	
<b>I max.</b>	1.5A	
<b>Size</b>	<a href="#">Check size and weight table</a>	
<b>Clock Speed</b>	16MHz	
<b>Flash Memory</b>	256KB of which 8KB used by bootloader	
<b>SRAM</b>	8KB	
<b>EEPROM</b>	4KB	
<b>Communications</b>	I2C – Ethernet Port – USB – RS485 – RS232 – SPI – (1x) RX, TX (Arduino pins) – DALI	Max232-Max485-W5500
<b>USB consideration!</b>	<b>Only meant for uploading or debugging, not always connected as a serial in a project!</b>	<b>Cannot be working in a final application</b>
<b>An/Dig Input 10bit</b> (0-10Vcc)	0 to 10Vdc Input Impedance: 39K Separated PCB ground Rated Voltage: 10Vdc  5 to 24Vdc I min: 2 to 12mA Galvanic Isolation Rated Voltage: 24Vdc ===	Max read time: 116us  *Check <a href="#">Section 14</a> for digital inputs threshold detection
<b>Digital Isolated Input</b> (24Vcc)	5 to 24Vdc I min: 2 to 12mA Galvanic Isolation Rated Voltage: 24Vdc ===	All Digital Inputs are PNP. Click <a href="#">here</a> <sup>1</sup> for more information.  Max read time: 8us
<b>* Interrupt isolated Input HS</b> (24Vcc)	5 to 24Vdc I min: 2 to 12mA Galvanic Isolation Rated Voltage: 24Vdc ===	Max read time: 8us
<b>Analog Output 8bit</b> (0-10Vcc)	0 to 10Vdc I max: 20mA Separated PCB ground Rated Voltage: 10Vdc ===	Output frequency: 2Hz  Rising edge time: 150ms Falling edge time: 252ms
<b>Digital Isolated Output</b> (24Vcc)	5 to 24Vdc I max: 70mA Galvanic Isolation Diode Protected for Relay Rated Voltage: 24Vdc ===	I <sub>max</sub> 24Vdc: 410mA  With 70us delay, freq is 6.849MHz with pulse width of 106us  Rising edge time: 476ns Falling edge time: 42.8us

<sup>1</sup> <https://www.industrialshields.com/blog/arduino-industrial-1/post/npn-digital-inputs-on-industrial-plc-193>

<b>Digital Isolated Output</b> Relay	30Vdc / 250Vac Galvanic Isolation Diode protected for Relay ==	I <sub>max</sub> : 3A (30Vdc) I <sub>max</sub> : 5A (250Vac)
<b>PWM Isolated Output</b> 8bit (24Vcc)	5 to 24Vdc I max: 70mA Galvanic Isolation Diode Protected for Relay Rated Voltage: 24Vdc ==	
<b>Direct Arduino Pin</b> Output	0 to 5Vdc I max: 40mA Rated Voltage: 5Vdc	Max frequency: 77kHz Rising edge time: 200ns Falling edge time: 200ns
<b>Direct Arduino Pin</b> Input	0 to 5Vdc I max: 40mA Rated Voltage: 5Vdc	Max read time: 8us
<b>I2C Pin</b>	5V Pull-up	Max frequency: 100kHz Rising edge time: 10us Falling edge time: 150ns
<b>One-Wire Pin</b>	Usable pins: Pin 2, Pin3, SCL, SDA, RX0, TX0, MISO, MOSI, SCK	Frequency: 800kHz
<b>Expandability</b>	I2C - 127 elements - Serial Port RS232/RS485	
<b>* By using this type of signal can no longer use Digital signal (24Vdc)</b>		



## 1.7 Power consumption of the M-Duino DALI Family PLCs

Model	Current resting (mA)	Power resting (W)	Current active (mA)	Power active (W)
21+	99	2,376	120	2,88
42+	92	2,208	128	3,072
58+	76	1,824	126	3,024
19R+	80	1,92	202	4,848
38R+	77	1,848	313	7,512
57R+	73	1,752	425	10,2
38AR+	72	1,728	221	5,304
53ARR+	71	1,704	323	7,752
57AAR+	71	1,704	221	5,304
54ARA+	76	1,824	231	5,544
50RRA+	82	1,968	322	7,728

The power consumption is measured at 24Vdc.



The **current resting** column denotes the minimum current drawn by the PLC when all outputs are at a LOW level, representing the PLC's baseline power consumption.

In contrast, the **current active** column reflects the current drawn by the PLC when all outputs are at a HIGH level, and there are no connections to any of the outputs. While this value is not the absolute maximum the Arduino based PLC can draw, it serves as a reference point for expected current values.

It's important to note that the practical maximum current may vary depending on the type of actuators connected to the outputs and the number of I/Os used. The actual consumption can be influenced by the specific configuration and load connected to the PLC's outputs."

## 2 Technical Specifications:

### 2.1 General Specifications:







Item		M-Duino DALI Family PLC
Power supply voltage	DC power supply	12 to 24Vdc
Operating voltage range	DC power supply	11.4 to 25.4Vdc 
Power consumption	DC power supply	30W max.
External power supply	Power supply voltage	24Vdc 
	Power supply output capacity	700mA
Insulation resistance		20MΩ min.at 500Vdc between the AC terminals and the protective earth terminal.
Dielectric strength		2.300Vac at 50/60 Hz for one minute with a leakage current of 10mA max. Between all the external AC terminals and the protective ground terminal.
Shock resistance		80m/s <sup>2</sup> in the X, Y and Z direction 2 times each.
Ambient temperature (operating)		0° to 60°C
Ambient humidity (operating)		10% to 90% (no condensation)
Ambient environment (operating)		With no corrosive gas
Ambient temperature (storage)		-20° to 60°C
Power supply holding time		2ms min.
Weight		<a href="#">Check size and weight table</a>

### 2.2 Performance Specification:

Arduino Board	ARDUINO MEGA 2560
Control method	Stored program method
I/O control method	Combination of the cyclic scan and immediate refresh processing methods.
Programming language	Arduino IDE. Based on wiring (Wiring is an Open Source electronics platform composed of a programming language. "similar to the C". <a href="http://arduino.cc/en/Tutorial/HomePage">http://arduino.cc/en/Tutorial/HomePage</a> )
Microcontroller	ATmega2560
Flash Memory	256KB of which 8KB are used by the bootloader
Program capacity (SRAM)	8KB
EEPROM	4KB
Clock Speed	16MHz

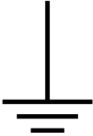
## 2.3 Symbology

Table that includes all the symbology that is used in the serigraph of the M-Duino DALI PLC Family:

Symbol	Standard No. / Standard Title	Standard Reference No. / Symbol Title	Symbol Meaning
	IEC 60417 / Graphical symbols for use on equipment	5031 / Direct Current	Indicates that the equipment is suitable for direct current only; to identify relevant terminals
	IEC 60417 / Graphical symbols for use on equipment	5032 / Alternating Current	Indicates that the equipment is suitable for alternating current only; to identify relevant terminals
	IEC 60417 / Graphical symbols for use on equipment	5130 / Pulse General	To identify the control by which a pulse is started.
	IEC 60417 / Graphical symbols for use on equipment	5017 / Earth, Ground	To identify an earth (ground) terminal in cases where neither the symbol 5018 nor 5019 is explicitly required.
	IEC 60417 / Graphical symbols for use on equipment	5115 / Signal lamp	To identify the switch by means of which the signal lamp(s) is (are) switched on or off.
	2004/108/EC / Electromagnetic Compatibility	CE Marking	CE marking indicates that a product complies with applicable European Union regulations
	ISO 7000/ Graphical symbols for use on equipment	0434B / Warning symbol	Indicates a potentially hazardous situation which, if not avoided, could result in death or serious injury
	ISO 7000/ Graphical symbols for use on equipment	5036 / Dangerous Voltage	To indicate hazards arising from dangerous voltages

## 3 Precautions

Read this manual before attempting to use any of the M-Duino DALI PLC Family and follow its descriptions for reference during operation.

### 3.1 Arduino Board

The M-Duino DALI Family PLCs include Arduino Mega Board as controller.

### 3.2 Intended Audience

This manual is intended for technicians, which must have knowledge on electrical systems.

### 3.3 General Precautions

The user must operate an M-Duino according to the performance specifications described in this manual. Before using M-Duino under different conditions from what has been specified in this manual or integrating M-Duino to nuclear control systems, railroad systems, aviation systems, vehicles, combustion systems, medical equipment, amusement machines, safety equipment and other systems, machines, and equipment that may have a serious influence on lives and property if used improperly, consult your INDUSTRIAL SHIELDS representative. Ensure that the rating and performance characteristics of M-Duino are sufficient for the systems, machines, and equipment, and be sure to provide the systems, machines, and equipment double safety mechanisms. This manual provides information for programming and operating the M-Duino.

### 3.4 Isolation Precautions

#### Description:

This equipment does **not include galvanic isolation between the grounds** of the different systems. This means that if an external device or sensor that shares the same ground reference (GND) with the system is connected, any potential difference between these grounds could damage the connected components. To avoid issues with interference, ground loops, or damage to external equipment, ensure that all connected devices share the same ground reference or use systems with appropriate isolation.

#### Recommendations:

- **Connection Review:** Verify that all ground connections are properly made and that there are no significant potential differences between them.
- **Use of Isolation:** Consider using galvanic isolators or isolation transformers if it is necessary to connect equipment with different ground references.

## 4 M-Duino Pinout

Model	Reference	IOs Table					
		Analog Input* <sup>1</sup>	Digital Isolated Input	Digital Isolated Output	Digital/Analog Output	Relay Output	PWM Isolated Output* <sup>2</sup>
19R+	004001000100	4	2	0	3	8	3
21+	004001000200	6	7	8	3	0	3
38AR+	004001000700	10	7	5	6	8	6
38R+	004001000300	8	2	0	3	16	6
42+	004001000400	12	12	10	6	0	6
50RRA+	004001000900	12	8	4	8	16	8
53ARR+	004001001000	14	9	5	8	15	8
54ARA+	004001001100	14	13	9	8	8	8
57AAR+	004001000800	16	14	10	8	7	8
57R+	004001000500	12	4	0	8	23	8
58+	004001000600	16	18	14	8	0	8

\*<sup>1</sup> The analog inputs can also be used as digital inputs.

\*<sup>2</sup> The PWM isolated outputs can also be used as digital isolated outputs. The associated PWM and analog outputs cannot be used at the same time (check [switch configuration](#)).

## 5 Serigraphy

### 5.1 A Zone connection (Communications)

Base		
A Zone		
M-Duino Connector	Arduino Pin	Function
AREF	AREF	Arduino Pin
SQW	SQW	Arduino Pin
-	-	-
3.3Vdc	3.3Vdc	Arduino Pin
5Vdc	5Vdc	-
GND	GND	GND

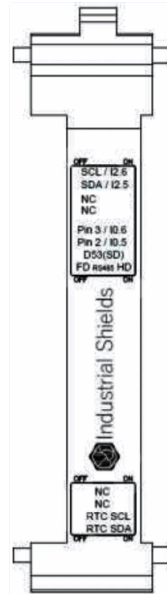

Base		
A Zone		
M-Duino Connector	Arduino Pin	Function
SCL	21	I2C/SS
SDA	20	I2C/SS
RX0	0	RX0/SS
TX0	1	TX0/SS
-	-	-
-	-	-
TX	16	RX2(serial 2)
RX	17	TX2(serial 2)
Z-	-	RS485
Y+	-	RS485
B-	-	RS485
A+	-	RS485
PIN3	3	Arduino Pin
50 SO	50	SPI
51 SI	51	SPI
52 SCK	52	SPI
Reset	Reset	SPI
Vin5	Vin5	5V
PIN2	2	Arduino Pin
GND	-	Gnd
GND	-	Gnd
24Vdc	-	Power Supply

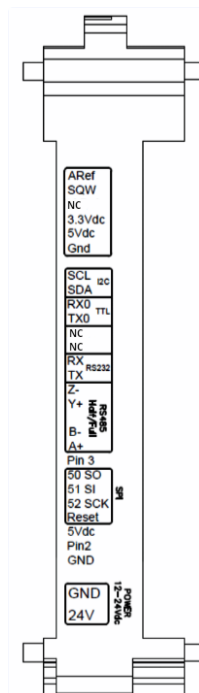

Configuration Switch\* (see section 8 to select the correct configuration for outputs. Enabling communications disables some I/Os).

Communication Pins

Power supply connectors (24Vdc - GND)

SS: Chip Select pins. These pins can act as TTL, so they can work for the Chip Select pin of any device.

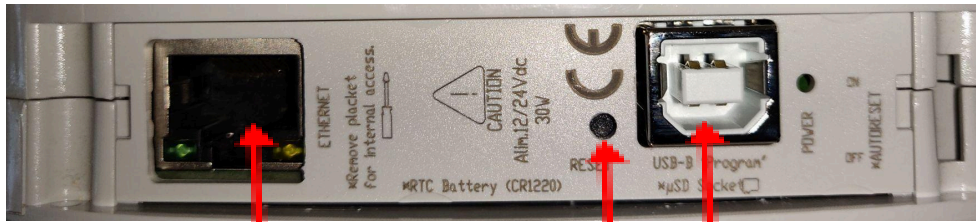

Ethernet

Reset USB-B

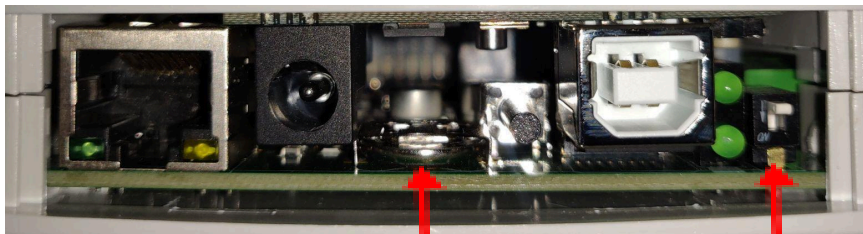

RTC battery

Programmable button

## 5.2 Analog/Digital Zone connection (I/Os)

<b>X Zone</b>	
M-Duino Connector	Function
<b>IX.12</b>	Analog/Digital In*
<b>IX.11</b>	Analog/Digital In*
<b>IX.10</b>	Analog/Digital In
<b>IX.9</b>	Analog/Digital In
<b>IX.8</b>	Analog/Digital In
<b>IX.7</b>	Analog/Digital In
<b>(-)IX.6</b>	GND IX.6
<b>IX.6/INT</b>	Interrupt X In <sup>2</sup>
<b>(-)IX.5</b>	GND IX.5
<b>IX.5/INT</b>	Interrupt X In <sup>3</sup>
<b>(-)IX.4</b>	GND IX.4*
<b>IX.4</b>	Digital Input*
<b>(-)IX.3</b>	GND IX.3
<b>IX.3</b>	Digital Input
<b>(-)IX.2</b>	GND IX.2
<b>IX.2</b>	Digital Input
<b>(-)IX.1</b>	GND IX.1
<b>IX.1</b>	Digital Input
<b>(-)IX.0</b>	GND IX.0
<b>IX.0</b>	Digital Input

\*Connectors IX.12, IX.11 and IX.4 are not connected (NC) in D Zone.

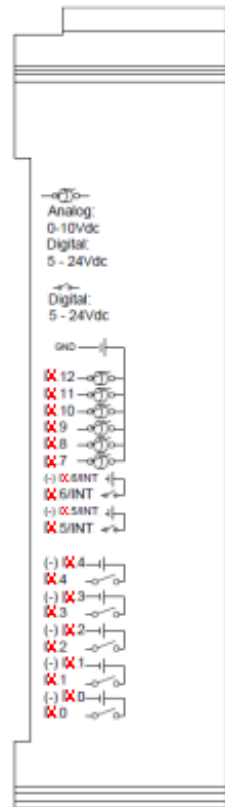

Analog/Digital Inputs

Interrupt Inputs (isolated)

Digital Inputs (isolated)

### Top Zone



Led indicator I/Os state

<b>X Zone</b>	
M-Duino Connector	Function
<b>GND</b>	GND
<b>AX.7</b>	Analog Out*
<b>AX.6</b>	Analog Out
<b>AX.5</b>	Analog Out
<b>QVdc</b>	External Isolated Out Vdc
<b>COM(-)</b>	External Isolated Out GND
<b>QX.7</b>	Digital/PWM Out*
<b>QX.6</b>	Digital/PWM Out
<b>QX.5</b>	Digital/PWM Out
<b>QX.4</b>	Digital Out*
<b>QX.3</b>	Digital Out
<b>QX.2</b>	Digital Out
<b>QX.1</b>	Digital Out
<b>QX.0</b>	Digital Out

\*Connectors AX.7, QX.7 and QX.4 are not connected (NC) in D Zone.

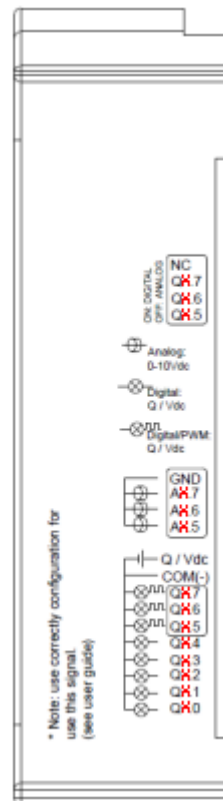

Configuration Switch\*

(see section 8 to select the correct configuration for outputs).

Analog Outputs

Voltage Supply/Reference for

Digital/PWM Outputs (isolated)

Digital Outputs

<sup>2</sup> See [section 5.4](#) to know more about interrupt pins.



### 5.3 Relay Zone connection (I/Os)

X Zone	
M-Duino Connector	Function
<b>RX.8</b>	Relay Out
<b>RX.7</b>	Relay Out
<b>RX.6</b>	Relay Out
<b>RX.5</b>	Relay Out*
<b>RX.4</b>	Relay Out
<b>AX.2</b>	Analog Out*
<b>AX.1</b>	Analog Out
<b>AX.0</b>	Analog Out
<b>GND</b>	GND
<b>QX.2</b>	Digital/PWM Out*
<b>QX.1</b>	Digital/PWM Out
<b>QX.0</b>	Digital/PWM Out
<b>COM(-)</b>	External Isolated Out Gnd
<b>QVdc</b>	External Isolated Out Vdc

\*Connectors RX.5, AX.2 and QX.2 are not connected (NC) in D Zone.

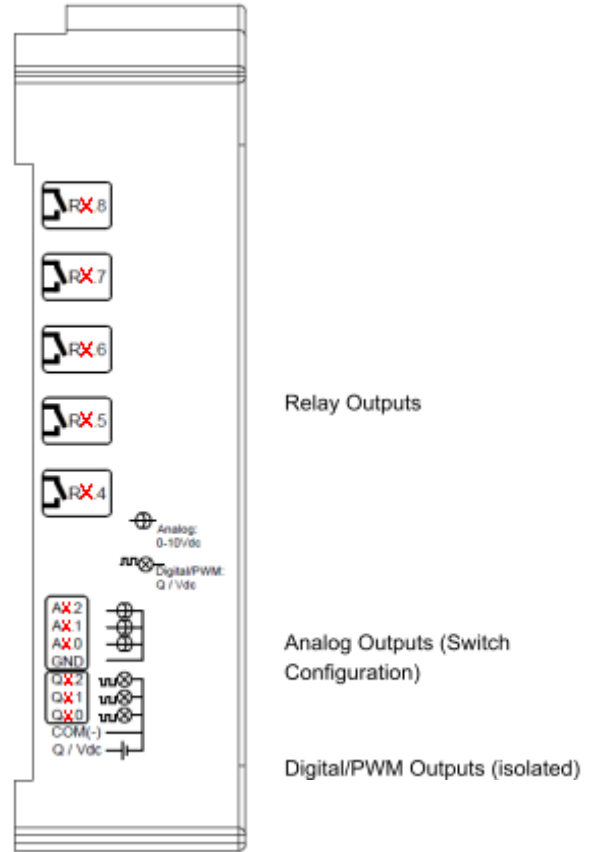

#### Top Zone

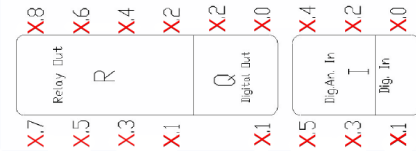

#### Led indicator I/Os state

X Zone	
M-Duino Connector	Function
<b>RX.3</b>	Relay Out
<b>RX.2</b>	Relay Out
<b>RX.1</b>	Relay Out
<b>GND</b>	GND
<b>IX.5</b>	Analog/Digital Input
<b>IX.4</b>	Analog/Digital Input
<b>IX.3</b>	Analog/Digital Input
<b>IX.2</b>	Analog/Digital Input
<b>IX.1/INT<sup>3</sup></b>	Interrupt X In
<b>(-)IX.1</b>	GND IX.1
<b>IX.0/INT<sup>4</sup></b>	Interrupt X In
<b>(-)IX.0</b>	GND IX.0

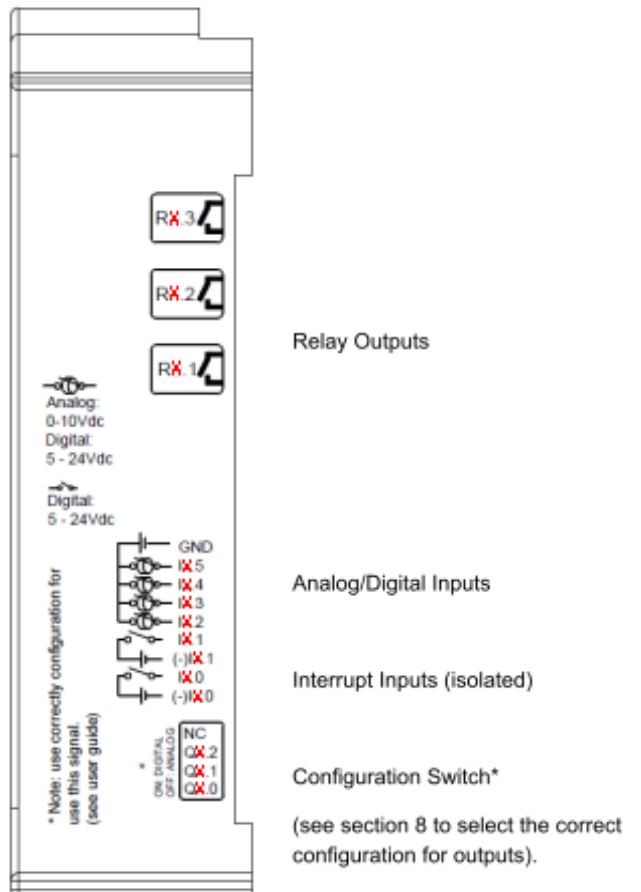

<sup>3</sup> See [section 5.4](#) to know more about interrupt pins.

## 5.4 Interrupt equivalence table

See the [Reference Table](#) in order to know the specific device details.

Zone	Analog/Digital			Relay		
	PLC Input	PLC Interrupt	M-Duino Pin	PLC Input	PLC Interrupt	M-Duino Pin
B	0.6	INT1	PIN3	0.1	INT1	PIN3
	0.5	INT0	PIN2	0.0	INT0	PIN2
C	-	-	-	-	-	-
	-	-	-	-	-	-
D	2.5	INT3	PIN21	2.1	INT3	PIN21
	2.6	INT2	PIN20	2.0	INT2	PIN20

Check this [link](#) for more information.

## 6 Software interface

Industrial Shields PLC are programmed using Arduino IDE, which is a software based on the C language. They can also be programmed directly using C, but it is much easier working with Arduino IDE, as it provides lots of useful libraries.

Industrial Shields provide a boards package for programming the PLCs, making it easier and friendlier. It includes various facilities such as not having to define the pins, etc.

In order to install Industrial Shields boards, these are the steps that must be followed.

### Requirements:

Arduino IDE 1.8.15 or above (recommended: 1.8.19).

### Steps:

1. Open Arduino IDE and go to: "File -> Preferences" located in the top left corner.

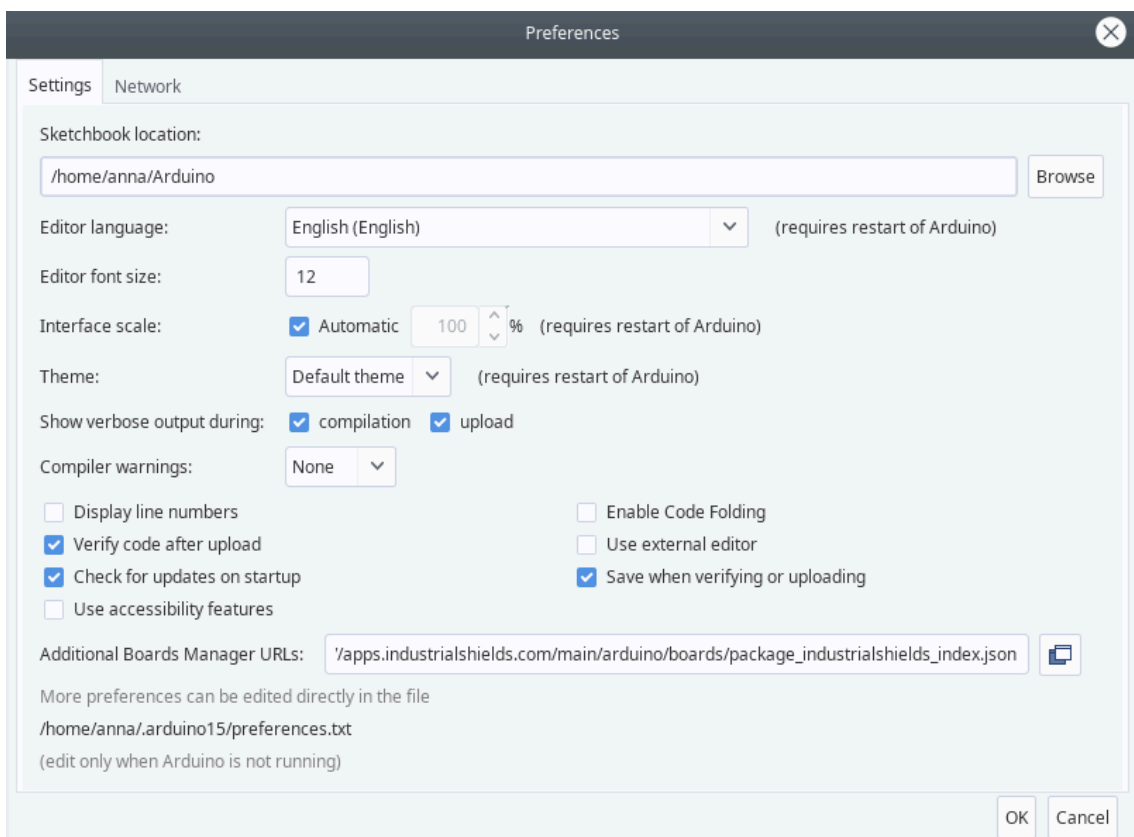

- In Additional Boards Manager URLs write the following:

[http://apps.industrialshields.com/main/arduino/boards/package\\_industrialshields\\_index.json](http://apps.industrialshields.com/main/arduino/boards/package_industrialshields_index.json)

- Press OK to save the changes.
- Go to: Tools -> Board: ... -> Boards Manager

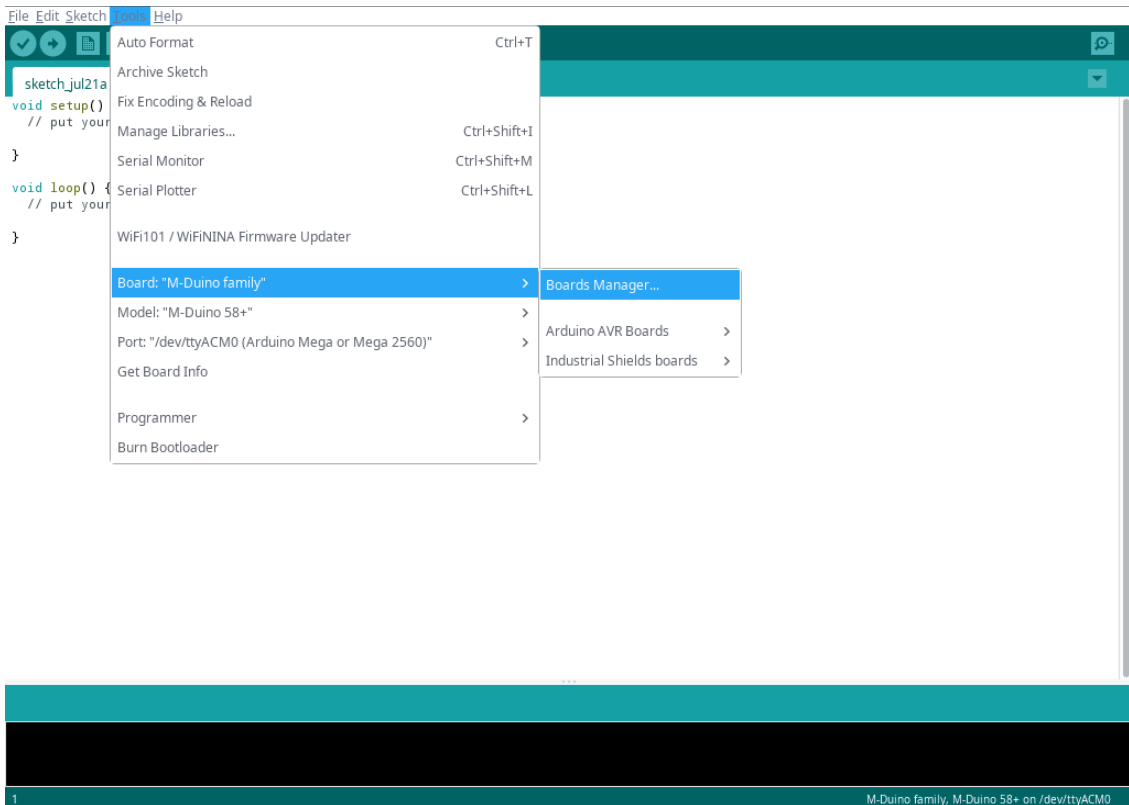

- Search for "industrialshields" on the browser.

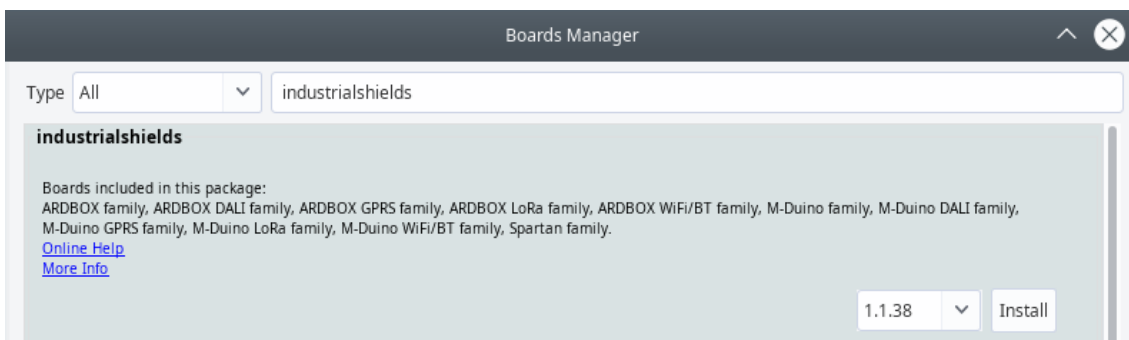

6. Click install (selecting the latest version).

Following these steps you will be able to see now the Industrial Shields Boards:

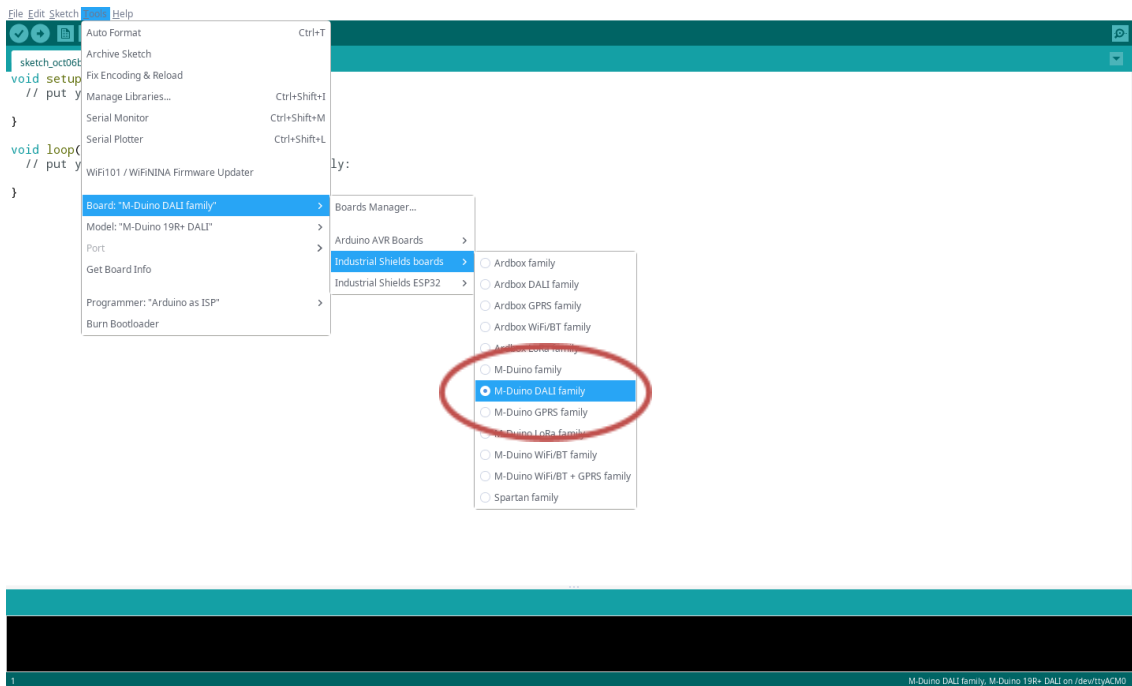

Once it is selected M-Duino DALI Family, an extra option will appear on Tools: There, it can be selected the exact model for every family.

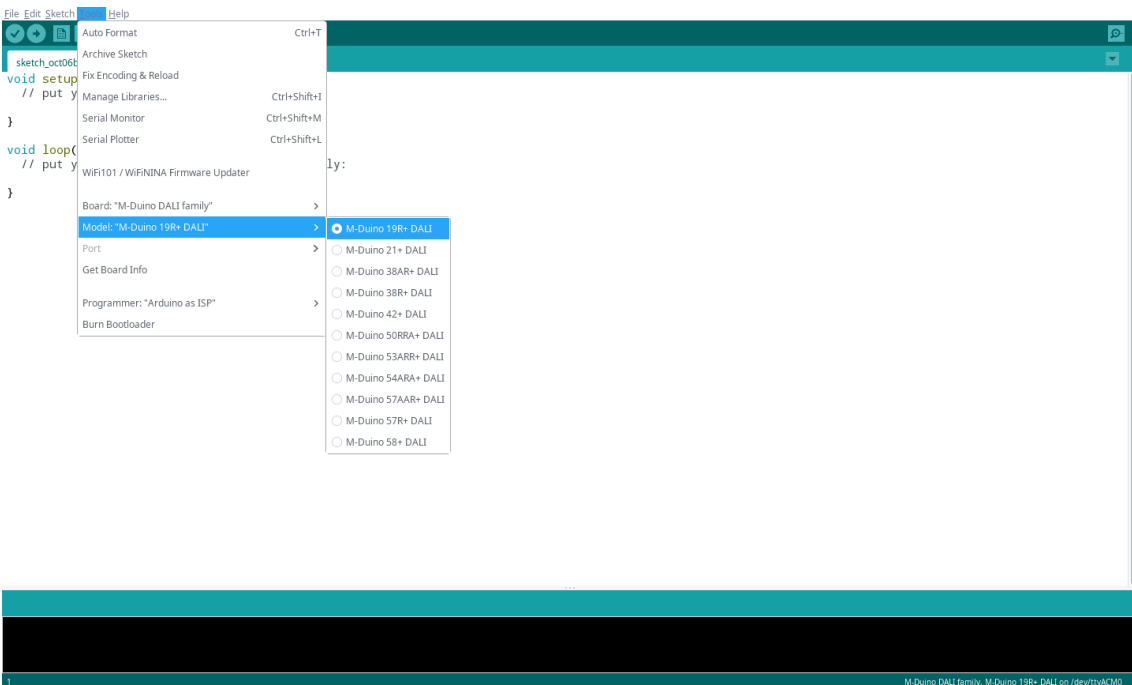

Also there are some examples of programming in File -> Examples -> Examples for M-Duino DALI family.

Furthermore there are some extra libraries that can be found in Industrial Shields github.

<https://github.com/Industrial-Shields/>

## 7 How to connect PLC Arduino to PC

- Connect USB port from PLC to PC.



**NOTE:**

M-Duino DALI Family uses B-USB cable.

- Open Arduino IDE interface:
- Select Industrial Shields boards -> M-Duino DALI Family
- Select the correct M-Duino Board (M-Duino 19R+ DALI in our example).

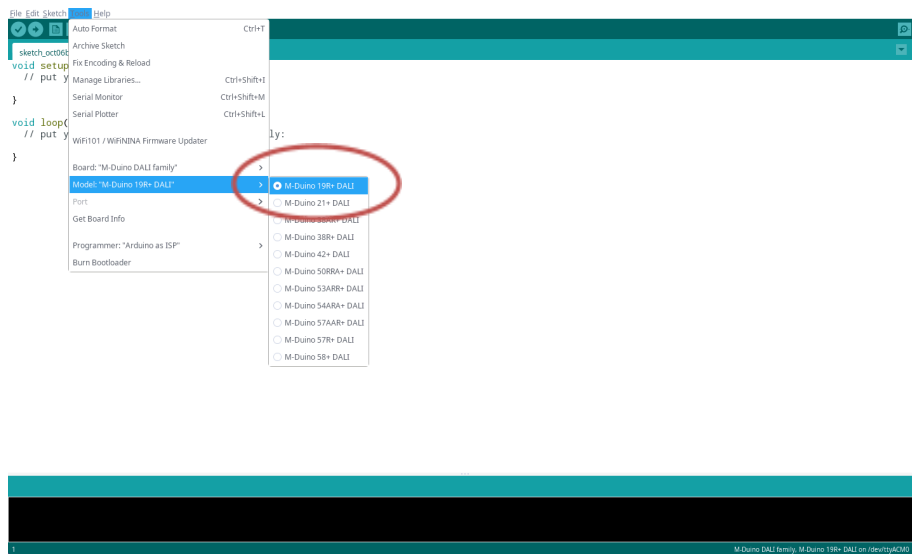

- Select the correct port.

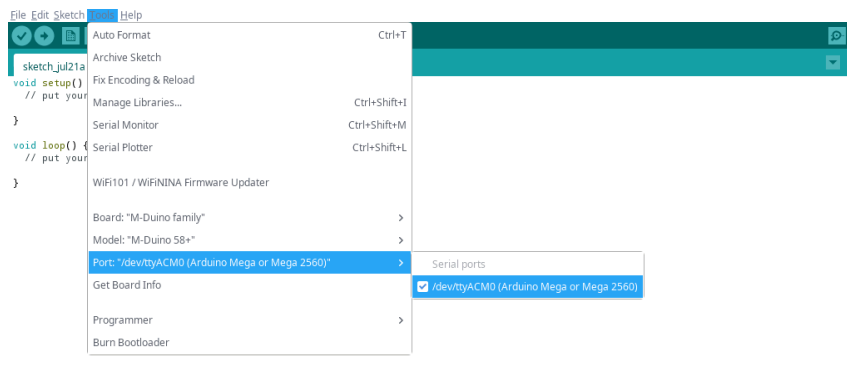

## 8 How to connect PLC to power supply

- M-Duino DALI Family PLCs are 12-24Vdc supplied. **IMPORTANT: The polarity IS NOT REVERSIBLE!**
- Make sure that the live and GND connector of the power supply match the PLC.
- Make sure that the power supply mains output is not higher than 24Vdc.

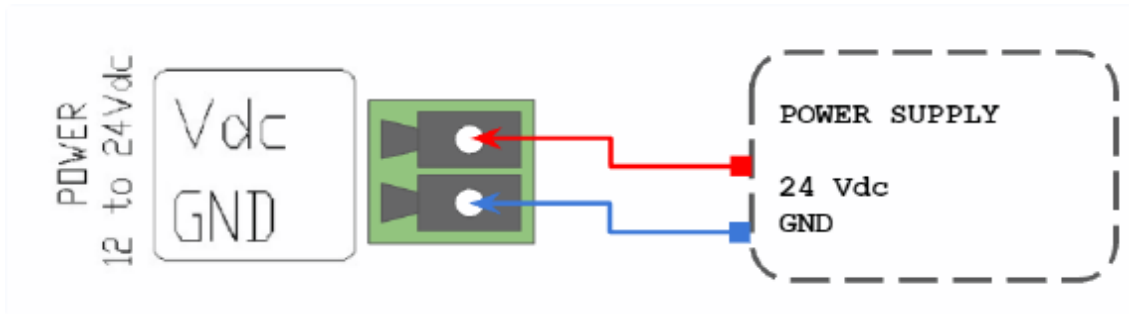

- Suggested power suppliers

Compact DIN rail power supply. Assembled on 35mm DIN Rail:  
 -12Vdc / 24Vdc  
 -2.5A  
 -30W

Industrial Shields power supplies provide parallel operation, overvoltage protection, and overcurrent protection. There is a LED indicator for power status, the power supply is certified according to UL.



The standard, Part 1 of IEC 61010, sets the general safety requirements for the following types of electrical devices and their accessories, regardless of where use of the device is intended.

The equipment must be powered from an external power source in accordance with IEC 61010-1, whose output is MBTS and is limited in power according to section 9.4 of IEC 61010-1.

**WARNING:** Once the equipment is installed inside an electrical cabinet, the MTBS cables of the equipment must be separated from the dangerous voltage cables.

## 9 Switch configuration

### 9.1 A Zone: Communications

A Zone		
Switch	OFF	ON
SCL   XX	SCL	XX
SDA   XX	SDA	XX
DALI   -	DALI	-
DALI   -	DALI	-
Pin 3   XX	Pin 3	XX
Pin 2   XX	Pin 2	XX
SD   XX	SD	XX
FD   HD	FD	HD

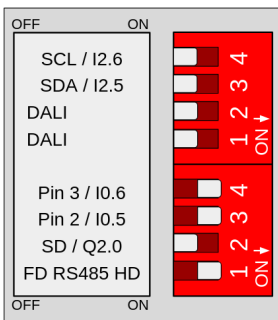

This is an D Zone Switch example from M-Duino 58+ DALI. In this case, SCL, SDA, I0.6, I0.5, Q2.0 and HD are enabled. This means SCL, SDA, Pin 3, Pin 2, SD and FD are disabled.

**4. SCL | XX:** Choosing between SCL or the input XX. If the switch is ON, it enables XX and disables SCL. If the switch is OFF, it enables SCL and disables XX. The serigraphy in the PLC will indicate which input is referred to XX.

**3. SDA | XX:** Choosing between SDA or the input XX. If the switch is ON, it enables XX and disables SDA. If the switch is OFF, it enables SDA and disables XX. The serigraphy in the PLC will indicate which input is referred to XX.

**2. DALI | - :** Always at OFF position.

**1. DALI | - :** Always at OFF position.



**4. Pin 3 | XX:** Choosing between Pin 3 or the input XX. If the switch is ON, it enables XX and disables Pin 3. If the switch is OFF, it enables Pin 3 and disables XX. The serigraphy in the PLC will indicate which input is referred to XX.

**3. Pin 2 | XX:** Choosing between Pin 2 or the input XX. If the switch is ON, it enables XX and disables Pin 2. If the switch is OFF, it enables Pin 2 and disables XX. The serigraphy in the PLC will indicate which input is referred to XX.

**2. SD | XX:** Choosing between SD or the input XX. If the switch is ON, it enables XX and disables SD. If the switch is OFF, it enables SD and disables XX. The serigraphy in the PLC will indicate which input is referred to XX.

**1. FD | HD:** Choosing between FD or HD. If the switch is ON, it enables HD and disables FD. If the switch is OFF, it enables FD and disables HD. Note: HD stands for Half Duplex and FD means Full Duplex. Check [section 11.2](#) for more information.

A Zone		
Switch	OFF	ON
NC	-	-
NC	-	-
NC   RTC	-	RTC
NC   RTC	-	RTC

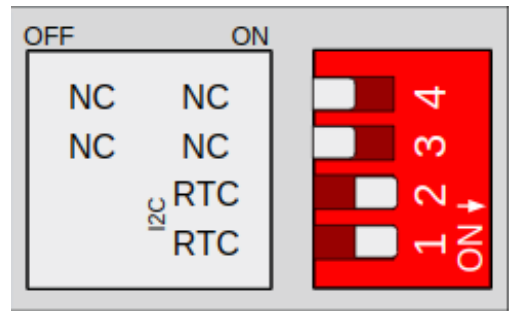

This switch enables the communication with RTC using I2C. Having both switches in ON mode activates the communication, whereas if they are in OFF mode I2C is disabled to reach the RTC.

## 9.2 Digital/Analogic Shield Switches

Digital/ Analogic Shield Switch		
Switch	OFF	ON
NC	-	-
AX.7   QX.7	AX.7	QX.7
AX.6   QX.6	AX.6	QX.6
AX.5   QX.5	AX.5	QX.5

\*X can change depending on which zone we are in. Check the serigraphy in the PLC to know what number takes X.

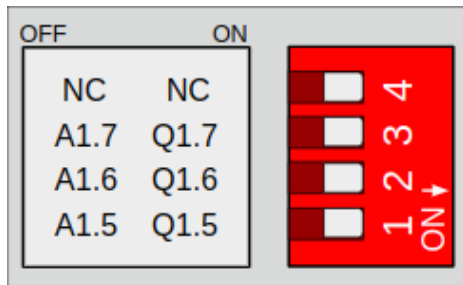

We can see here an example switch from the C Zone (Notice that X takes value 1 here).

For the Analog Shield if a switch is set to ON, it can only act as Digital Output. If it is set to OFF it can only act as an Analog Output.

If it is desired to use a Digital Output the switch must be set to ON and the pin that will provide this digital output is represented with QX.X, being X any number of the table above.

If it is desired to use an Analog Output the switch must be set to OFF and the pin that will provide this digital output is represented with AX.X, being X any number of the table above.

**\*IMPORTANT:** In D Zone, output A2.7 | Q2.7 is not connected.

### 9.3 Relay Shield Switches

Relay Shield Switch		
Switch	OFF	ON
NC	-	-
AX.2   QX.2	AX.2	QX.2
AX.1   QX.1	AX.1	QX.1
AX.0   QX.0	AX.0	QX.0

\*X can change depending on which zone we are in. Check the serigraphy in the PLC to know what number takes X.

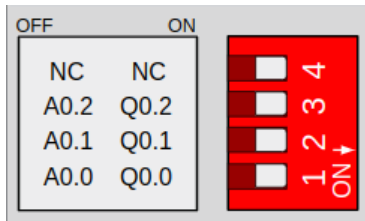

We can see here an example switch from the B Zone (Notice that X takes value 0 here).

For the Relay Shield if a switch is set to ON, it can only act as Digital Output. If it is set to OFF it can only act as an Analog Output.

If it is desired to use a Digital Output the switch must be set to ON and the pin that will provide this digital output is represented with QX.X, being X any number of the tables above.

If it is desired to use an Analog Output the switch must be set to OFF and the pin that will provide this digital output is represented with AX.X, being X any number of the tables above.

**\*IMPORTANT:** In D Zone, output A2.2 | Q2.2 is not connected.

## 10 M-Duino Arduino I/Os 5V pins

The M-Duino has some of the Mega board pins available. These pins can be programmed according to Arduino features such as I/Os operating at 5V or any additional features present in the pins (for example I2C communication in pins SCL and SDA). As these pins are directly connected to the Arduino Mega board they are not as well protected as the normal inputs. These pins are mainly meant to be used as prototyping.

The Arduino board available pins are summarised in the table below. In order to access some of these pins the configuration switch must be set to OFF position (see [section 9](#)) and some extra considerations must be taken in consideration when using these pins.

M-Duino terminal	Arduino pin	Enable Arduino pin
SCL	21	Communication switch: OFF
SDA	20	Communication switch OFF
RX0	0	
TX0	1	
RX	17	
TX	16	
MISO	50	
MOSI	51	
SCK	52	
Pin 3	3	Communication switch: OFF
Pin 2	2	Communication switch: OFF



**\*IMPORTANT:** Do not connect the terminals in the chart above to voltages higher than 5V. These terminals provide direct access to the Mega board.

Apart from the switch configuration there are some special conditions depending on these 5V. Now it is going to be shown the considerations to operate with these pins.

### 10.1 I2C pins – SDA/SCL

The I2C protocol is meant to work in a pull-up configuration. A pull-up configuration means that when the pin is at rest (nothing connected to it) it always reads a HIGH value. In this case it reads 5V when nothing is connected. The pull-up configuration is established by default in these pins.

If it is meant to use them as an internal arduino direct PIN at 5V, it has to be considered that they are pull-up inputs (2200Ω resistor is used in the internal pull-up).

## 10.2 Serial 0 – RX0/TX0

The Serial0 protocol can work also as a 5V pin. These pins should be used ultimately, only in case that all the 5V pins are already performing a function. This is because they are shared with the USB interface. If using these pins, the USB communication cannot be working at the same time.

When the PLC is not installed, USB communication is normally required for debugging or uploading/updating the program. If using both interfaces at the same time the Arduino board will get blocked.

These pins are not established with a pull-up or a pull-down configuration. The state of these pins is unknown. If these pins must be used, they require a pull-up or a pull-down configuration. The Arduino board allows the pins to be set in a pull-up configuration. If not it must be established as an external pull-up or pull-down circuit in order to correctly work with these pins.

## 10.3 SPI – MISO/MOSI/SCK

These pins can only work as 5V pins if the Ethernet protocol is not going to be used. As the Ethernet protocol uses the SPI to communicate with the Arduino board, both behaviours cannot happen at the same time as the Ethernet would not work.

These pins are not established with a pull-up or a pull-down configuration. The state of these pins is unknown. If these pins must be used, they require a pull-up or a pull-down configuration. The Arduino board allows the pins to be set in a pull-up configuration. If not it must be established as an external pull-up or pull-down circuit in order to correctly work with these pins.

## 10.4 Pin 2/Pin 3

To know how to configure these pins correctly, check [section 9](#).

These pins are not established with a pull-up or a pull-down configuration. The state of these pins is unknown. If these pins must be used, they require a pull-up or a pull-down configuration. The Arduino board allows the pins to be set in a pull-up configuration. If not it must be established as an external pull-up or pull-down circuit in order to correctly work with these pins.

## 11 A Zone Features: Communications & RTC & uSD

### 11.1 RS-232

The Arduino Mega function code to access the RS-232 port in the M-Duino is Serial2 (pins 16 and 17 of the Arduino Mega).

For the RS-232 communication protocol there isn't any switch that affects it. So it does not matter the configuration of the switches to implement a RS-232 communication.

Using the boards of Industrial Shields, there is a library that simplifies the RS-232 implementation.

Click [here](#)<sup>4</sup> or [here](#)<sup>5</sup> to see more about this communication.

### 11.2 RS-485

For RS485 communication protocol the defined Arduino Mega pins are shown in the chart below.

Function	Arduino Pin
DI	14
RO	15
RE	11
DE	46

For the RS-485 communication protocol there is only one switch that affects this communication. The RS-485 protocol will be always enabled, the only switch that affects is the one called "FD rs-485 HD" (See [Section 9](#)). This switch makes the choice between RS-485 Half Duplex or RS-485 Full Duplex (RS-422).

Using the boards of Industrial Shields, there is a library that simplifies the RS-485 implementation.

Click [here](#)<sup>6</sup> or [here](#)<sup>7</sup> to see more about this communication.

<sup>4</sup> <https://www.industrialshields.com/blog/arduino-industrial-1/post/basics-about-rs232-of-an-industrial-plc-183>

<sup>5</sup> <https://www.industrialshields.com/blog/arduino-industrial-1/post/how-to-use-rs-232-on-industrial-arduino-based-plc-16>

<sup>6</sup> <https://www.industrialshields.com/blog/arduino-industrial-1/post/basics-about-rs-485-of-an-industrial-plc-195>

<sup>7</sup> <https://www.industrialshields.com/blog/arduino-industrial-1/post/how-to-connect-two-industrial-plcs-through-rs-485-213>

## 11.3 I2C

I2C communication **DOES NOT REQUIRE** a pull-up resistor for the M-Duino. The pull-up resistor is already implemented in the PCB.

I2C communication is configured by switches, so the switches must be configured in order to enable the I2C communication (See [section 9](#) for more information).

Industrial Shields does not provide any library to implement the I2C as it can be used with the standard library of Arduino called Wire.

Click [here](#)<sup>8</sup> to see more about this communication.

## 11.4 SPI

The M-Duino pins used for the SPI bus are summarised in the table below. For SPI bus MISO, MOSI and CLOCK pins are common to all the connected devices to the M-Duino, conversely, each of the connected devices will have a single and dedicated SS pin.

Function	M-Duino connection	Mega board pin
MISO	50 S0	50
MOSI	51 SI	51
CLOCK	52 SCK	52
Reset	Reset	Reset
SS	SCL/SDA/RX0/TX0/RX3/TX3/Pin2/Pin3	21/20/1/0/15/14/2/3

Check the switch configuration at [section 9](#) to enable SS pins.

Click [here](#)<sup>9</sup> to see more about this communication.

## 11.5 TTL

M-Duino has two TTL ports, RX0/TX0, RX/TX. TTL0 is accessed with the function Serial (pins 0 and 1 of the Arduino Mega). TTL is accessed with the function Serial2 (pins 16 and 17 of the Arduino Mega). See [section 9](#) for more information.

## 11.6 Ethernet

M-Duino Ethernet port controller is based on w5500 IC, which is the IC compatible with Arduino Ethernet2 Shield libraries. All Ethernet shield Arduino libraries are compatible with the M-Duino. In the M-Duino, W5500 IC communicates to the Mega board via SPI bus (SS Arduino Mega pin 10). Click [here](#)<sup>10</sup> and [here](#)<sup>11</sup> to see more about this communication.

<sup>8</sup> <https://www.industrialshields.com/blog/arduino-industrial-1/post/i2c-bus-on-plc-arduino-for-industrial-automation-192>

<sup>9</sup> <https://www.industrialshields.com/blog/arduino-industrial-1/post/bus-spi-on-plc-arduino-from-industrial-shields-191>

<sup>10</sup> <https://www.industrialshields.com/blog/arduino-industrial-1/post/modbus-tcp-master-with-industrial-arduino-esp32-plcs-103>

<sup>11</sup> <https://www.industrialshields.com/blog/arduino-industrial-1/post/how-to-use-modbus-tcp-slave-library-with-a-plc-controller-arduino-105>

## 11.7 RTC

M-Duino RTC Module is based on the DS1307 Chip. This chip works with the I2C protocol communication, so it is required to have enabled the I2C protocol. This means 4 switches have to be configured in order to enable the RTC features.

RTC SCL & RTC SDA must be set to ON mode to enable the I2C wires to the RTC. If they are in OFF mode, the Arduino won't communicate with the RTC. Look at [section 11.3](#) for more information.

Using the boards of Industrial Shields, there is a library that simplifies the RTC implementation called RTC.

Click [here](#)<sup>12</sup> to see more about this feature.

## 11.8 uSD

The micro SD uses the SPI communication to interact with the Arduino Mega. The SPI protocol is always enabled, as there are no switches that configure it. However, there is a switch that must be placed to ON mode in order to communicate with the uSD:

SD: If this Switch is OFF, it enables the Chip Select of the microSD socket. If the switch is in ON mode the microSD can't be used. Check [section 9](#) for more information.

The uSD socket is found in the TOP part of the communication Shields, so in the frontal part of the PLC, it is required to open the plastic found in the frontal part and the socket is located under the supply of the Arduino.

Using the boards of Industrial Shields, there is a library that simplifies the uSD implementation called SD. It is the same as the Arduino library, with the only modification of using the pin 53 to select the Chip Select of the uSD chip.

Click [here](#)<sup>13</sup> to see more about this feature.

---

<sup>12</sup> <https://www.industrialshields.com/blog/arduino-industrial-1/post/rtc-test-on-m-duino-plus-version-51>

<sup>13</sup> <https://www.industrialshields.com/blog/arduino-industrial-1/post/basics-with-sd-card-in-an-industrial-plc-167>





**Verify that the CPU is not actively running a process before inserting the memory card.**

Inserting a memory card will cause the CPU to go to STOP mode, which could affect the operation of an online process or machine. Unexpected operation of a process or machine could result in death or injury to personnel and/or property damage. Before inserting a memory card, always ensure that the CPU is offline and in a safe state.



**Vérifiez que le processeur n'exécute pas activement un processus avant d'insérer la carte mémoire.**

Si vous insérez une carte mémoire, la CPU passe en mode STOP, ce qui peut affecter le fonctionnement d'un processus ou d'une machine en ligne. Le fonctionnement inattendu d'un processus ou d'une machine peut entraîner la mort ou des blessures corporelles et / ou des dégâts matériels. Avant d'insérer une carte mémoire, assurez-vous toujours que la CPU est hors ligne et en sécurité.

## 12 Examples

### 12.1 Lighting Protocol DALI in a PLC Arduino

To know what the DALI Protocol is and how it works in an industrial environment, look at this [post](#)<sup>14</sup>. A detailed description of DALI is done in it.

### 12.2 How to work with DALI Arduino Library and an industrial PLC

In this other [link](#)<sup>15</sup> a useful explanation on how the DALI Protocol can be implemented and used in industrial PLCs is given. Also, there is an example code to help in understanding the fundamentals of DALI communication.

---

<sup>14</sup>

<https://www.industrialshields.com/blog/arduino-industrial-1/post/lighting-protocol-dali-in-a-plc-arduino-238>

<sup>15</sup>

<https://www.industrialshields.com/blog/arduino-industrial-1/post/how-to-work-with-dali-arduino-library-and-an-industrial-plc-221>

## 13 Instructions for interconnection between Industrial Shields controllers

### 13.1 RS-232 Communication:

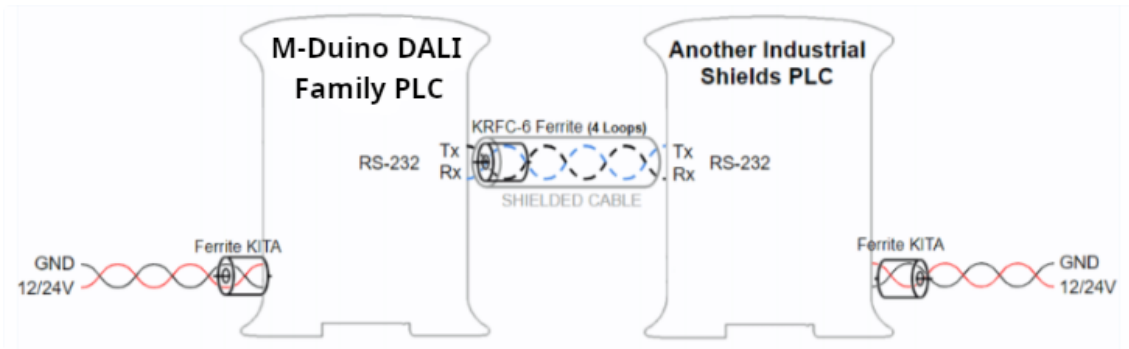

### 13.2 RS-485 Communication:

#### 13.2.1 Half Duplex

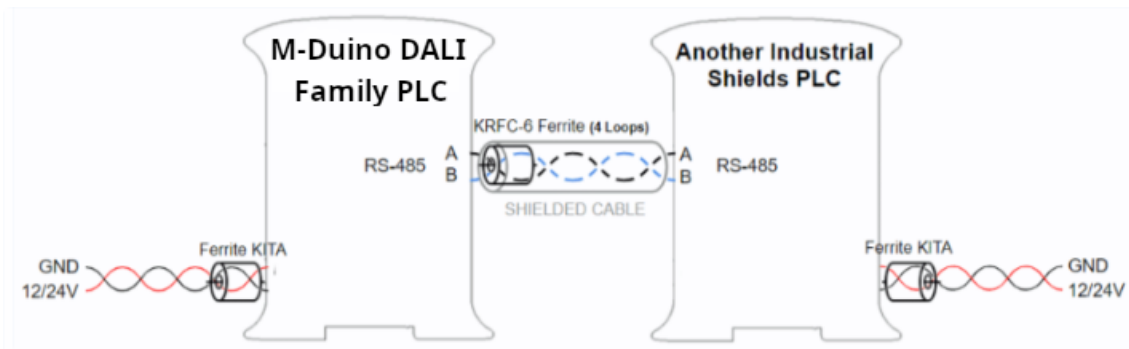

#### 13.2.2 Full Duplex

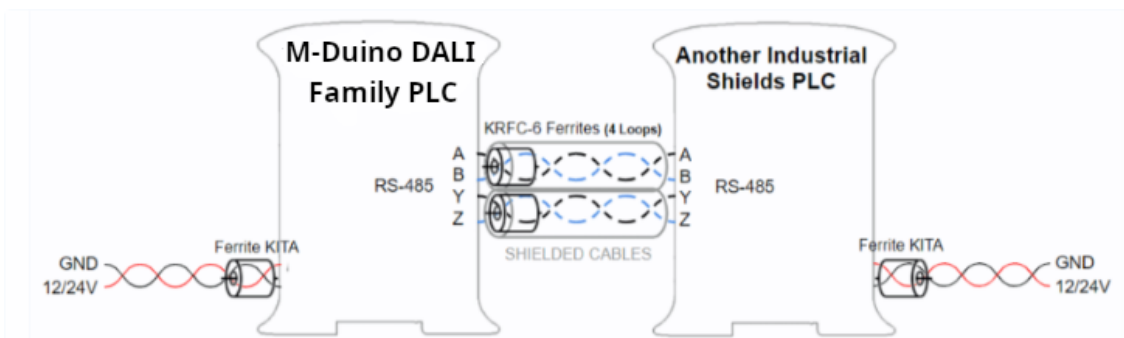

## 13.3 Ethernet

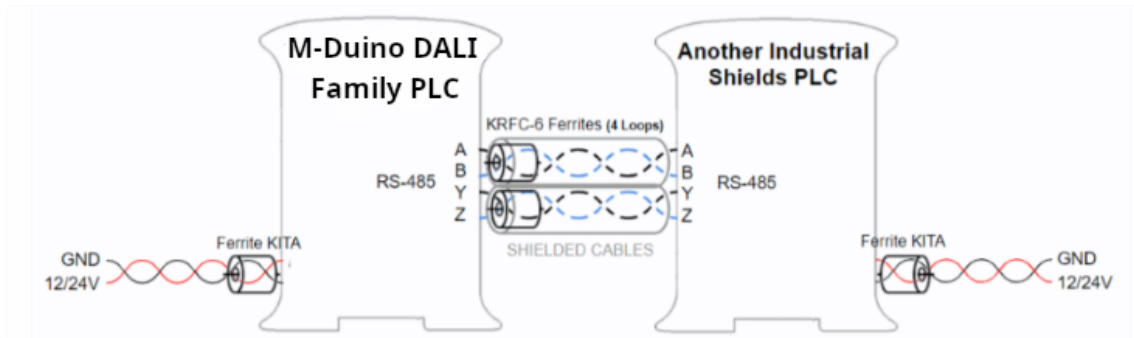

For Ethernet communication between Industrial Shields equipment a **SFTP CAT-6 Ethernet crossover cable** must be used.

## 14 Digital inputs threshold detection

The M-Duino inputs have a minimum voltage threshold to reliably detect the signal when used as digital input. The threshold value is different depending on the input type:

Input type	Threshold voltage (V)
Digital input	4
Analog input	5.1

## 15 I/O technical details

A comparison between the waveforms of the I/Os from the M-Duino DALI Family PLC and the Arduino Mega is done in this section.

Digital Output Waveform:

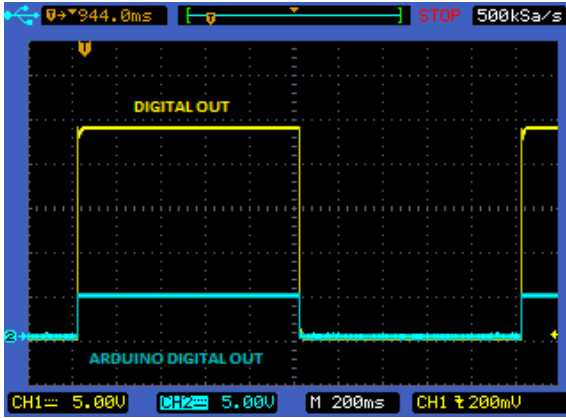

Digital Output Turn-off:

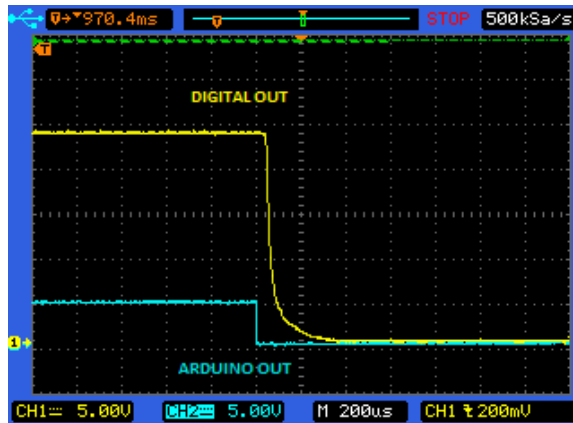

PWM Waveform:

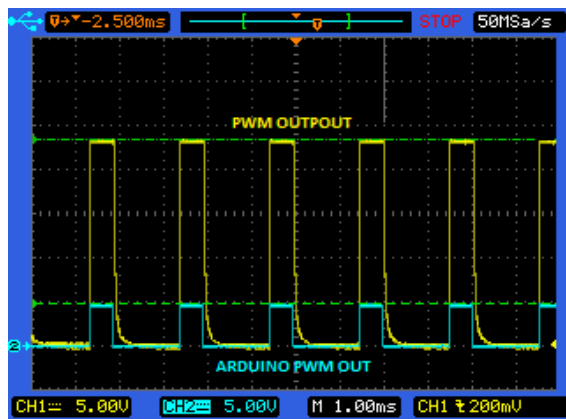

Analog Out Turn-On:

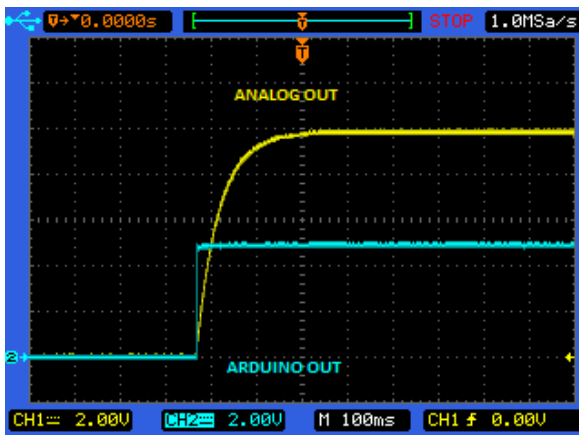

Analog Out Turn-Off:

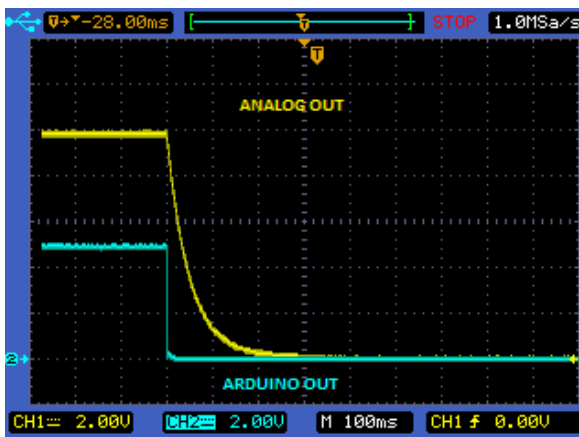

Analog /Digital input Turn-on:

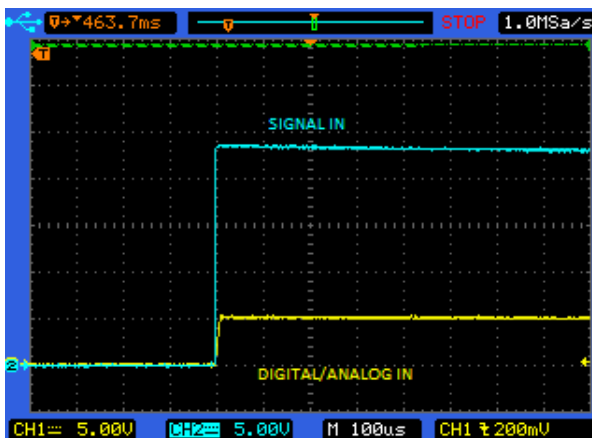

## 16 Typical Connections

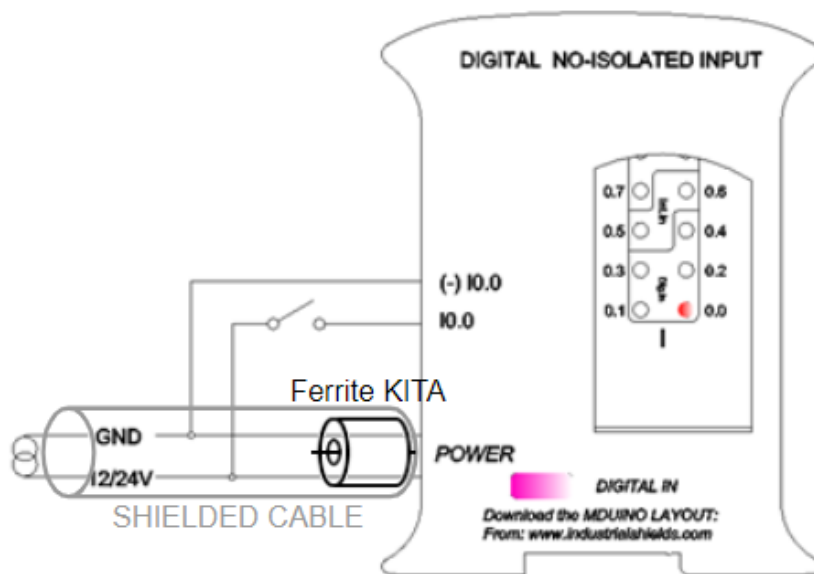
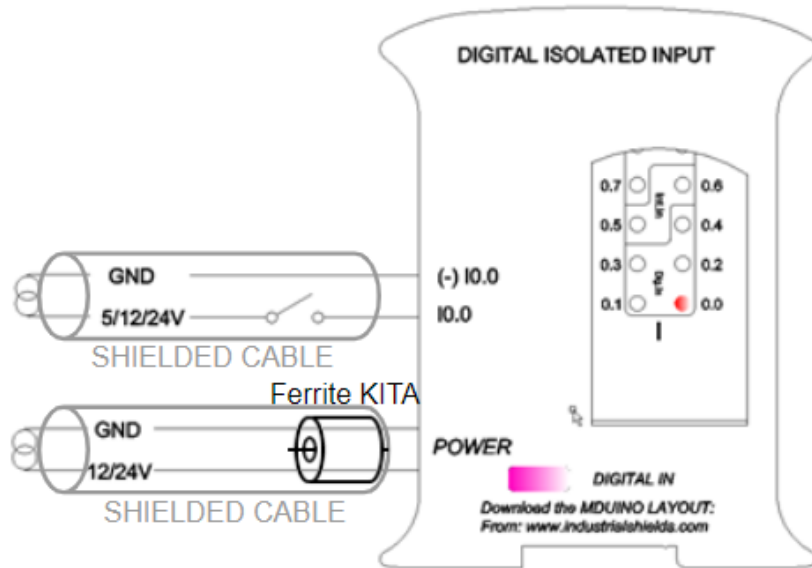

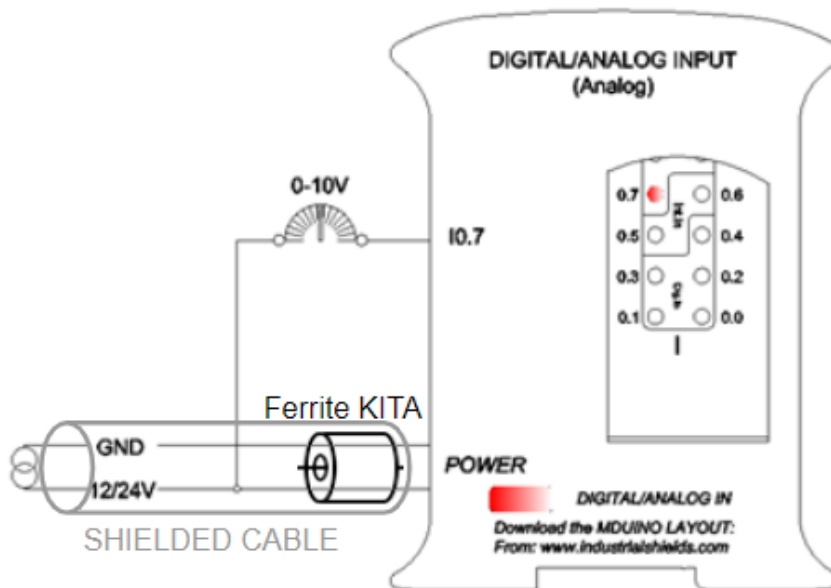
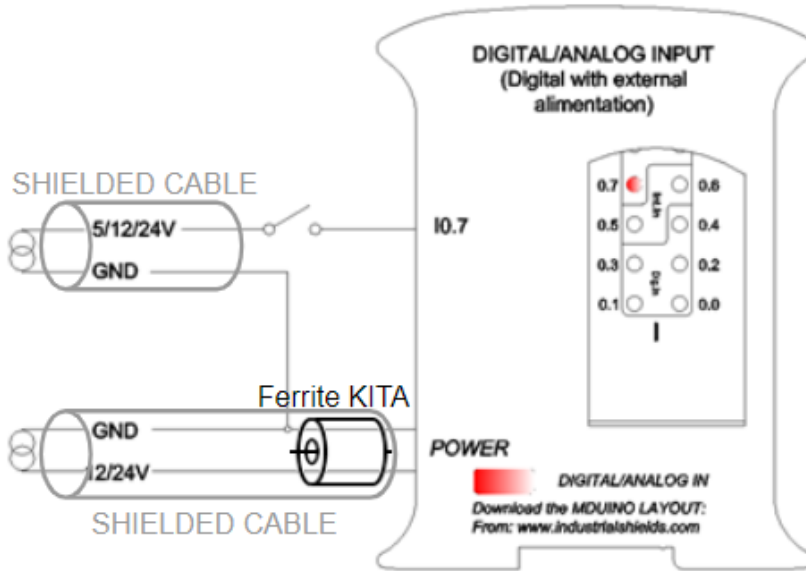



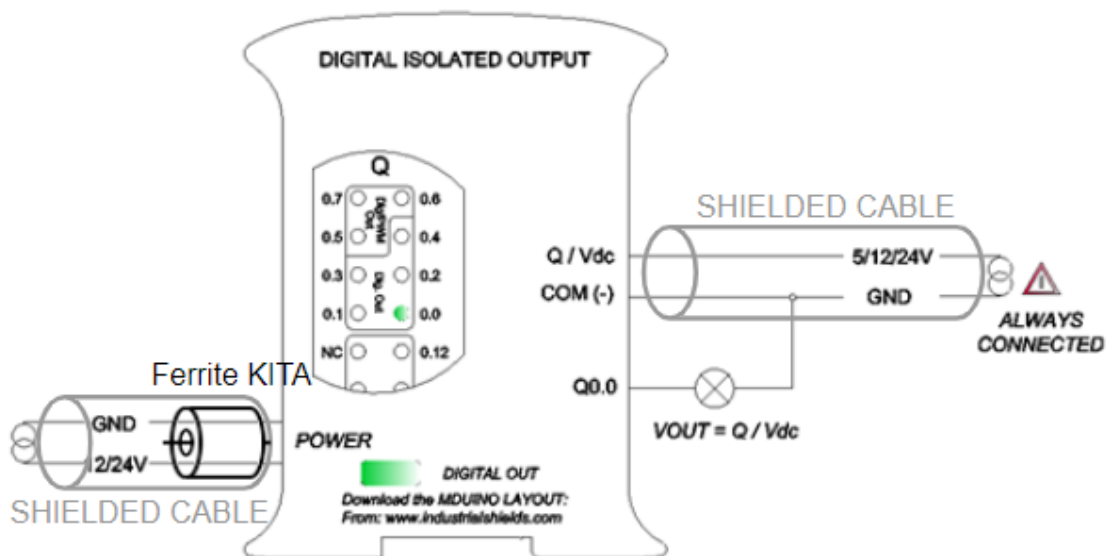
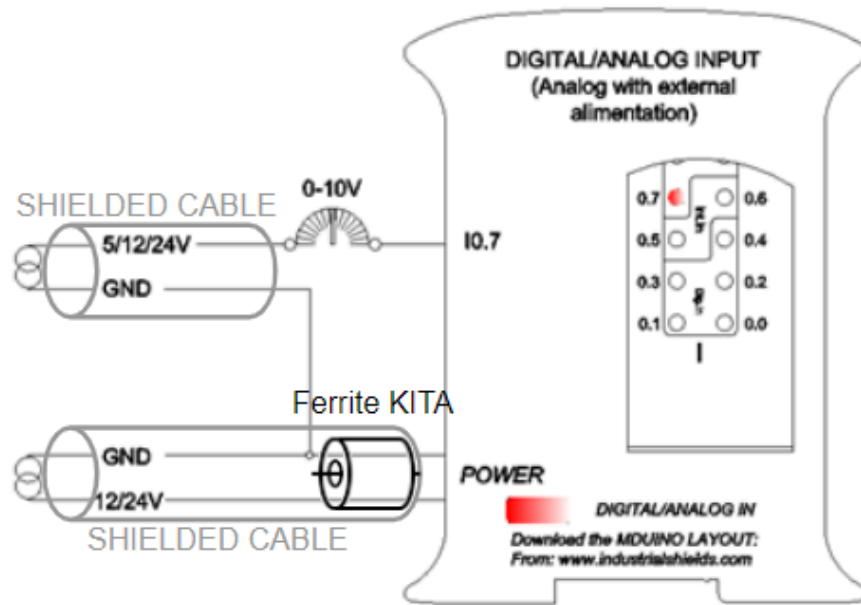

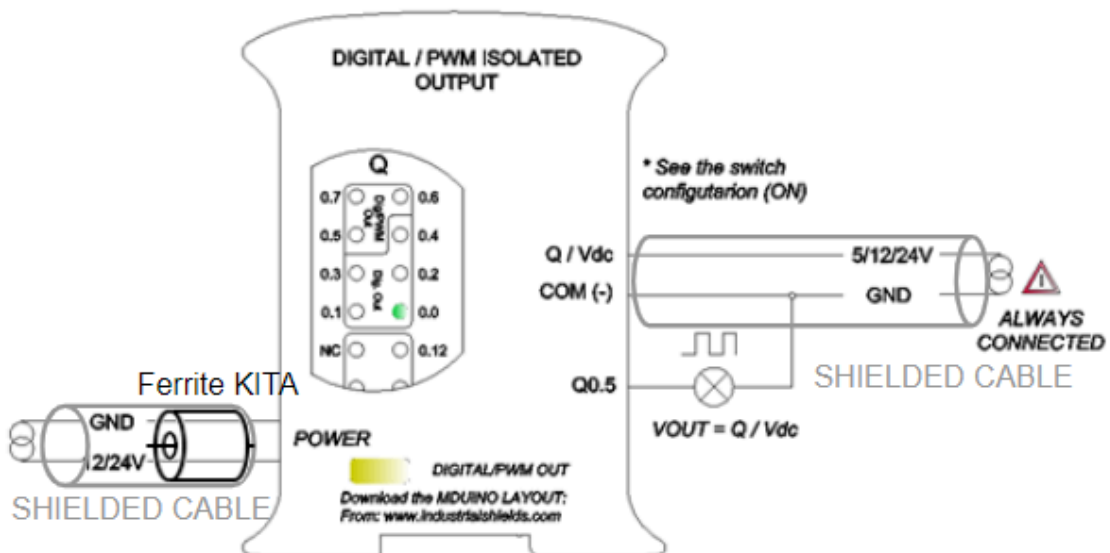
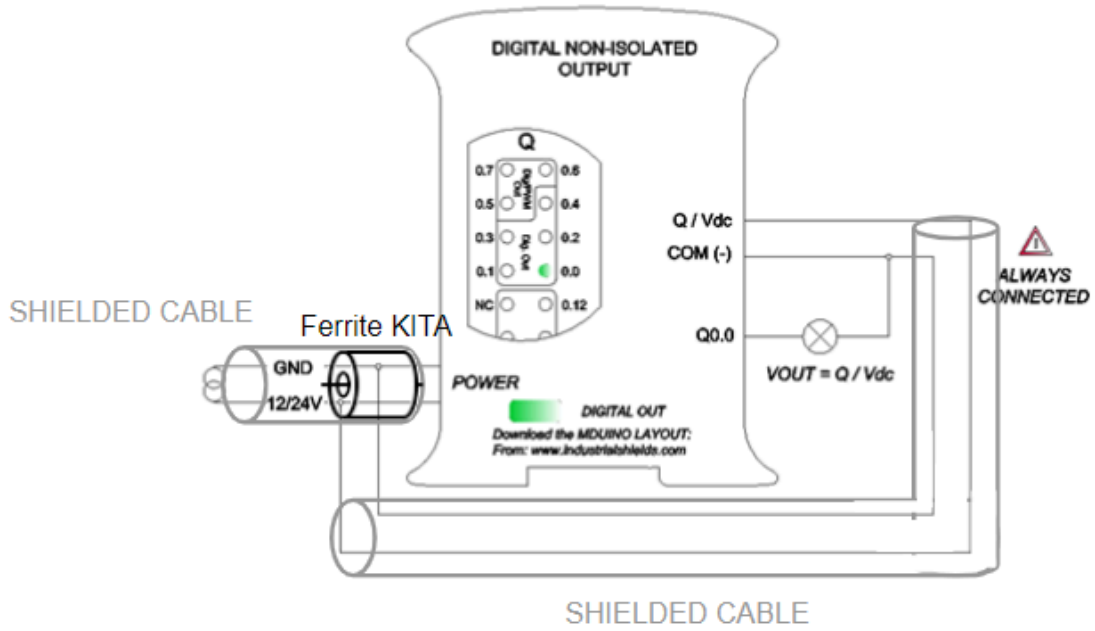

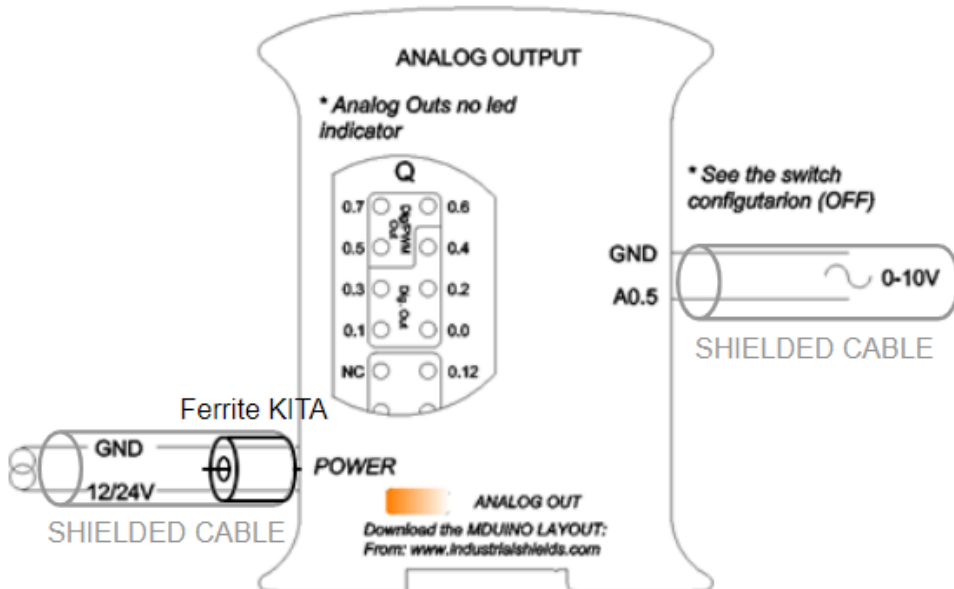
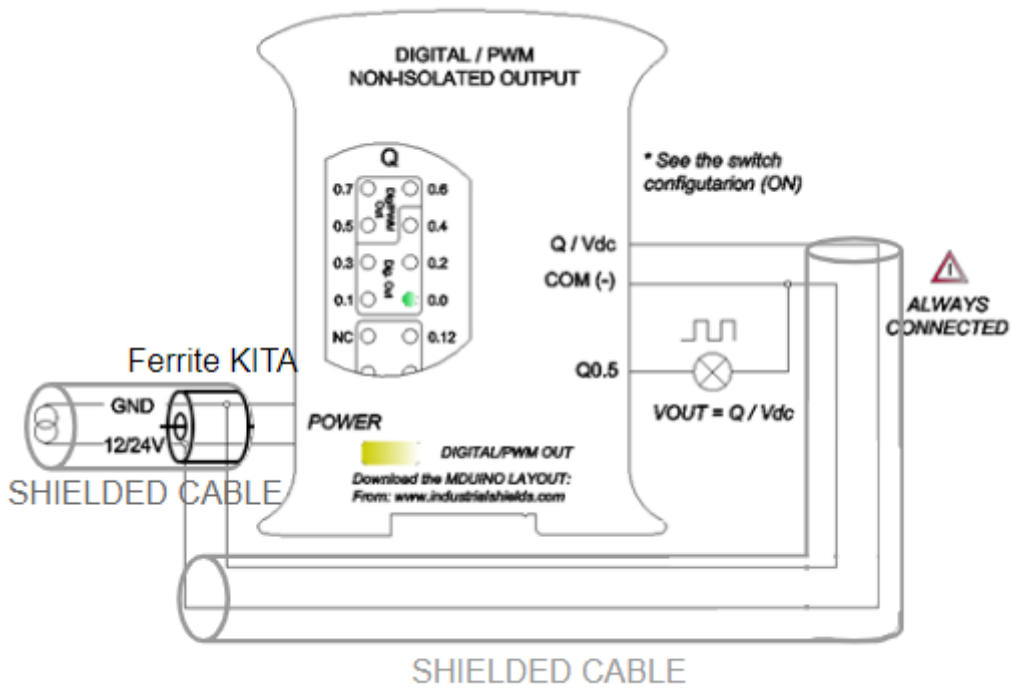

## 17 Connector details

The connector inside the PLCs that mounts on the PCB is [MC 0,5/10-G-2,5 - 1881529](#)<sup>16</sup> connector from Phoenix contact.

In the PLC we can find other connectors too, and these are the references for them:

MC 0,5/ 4-G-2,5 - 1881464

MC 0,5/ 6-G-2,5 - 1881480

MC 0,5/ 9-G-2,5 - 1881516

Connection details (10 pins):

<b>Article reference</b>	MC 0,5/10-G-2,5 - 1881529
<b>Height</b>	8.1 mm
<b>Pitch</b>	2.5 mm
<b>Dimension</b>	22.5 mm
<b>Pin dimensions</b>	0.8 x 0.8 mm
<b>Pin spacing</b>	2.5 mm

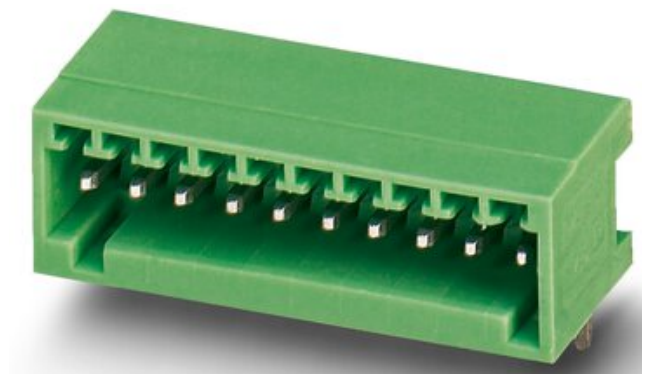

<sup>16</sup> <https://www.phoenixcontact.com/en-us/products/pcb-header-mc-0510-g-25-1881529>

For I/O and power supply there is a [FK-MC 0,5/10-ST-2,5 - 1881406](#)<sup>17</sup> connector from Phoenix contact.

In the PLC we can find other connectors too, and these are the references for them:

FK-MC 0,5/ 4-ST-2,5 - 1881341

FK-MC 0,5/ 6-ST-2,5 - 1881367

FK-MC 0,5/ 9-ST-2,5 - 1881396

Connection details (10 pins):

Article reference	FK-MC 0,5/10-ST-2,5
<b>Rigid conduit section min.</b>	0,14 mm <sup>2</sup>
<b>Rigid conduit section max.</b>	0,5 mm <sup>2</sup>
<b>Flexible conduit section min.</b>	0,14 mm <sup>2</sup>
<b>Flexible conduit section max.</b>	0,5 mm <sup>2</sup>
<b>Conduit section AWG/kcmil min.</b>	26
<b>Conduit section AWG/kcmil max.</b>	20

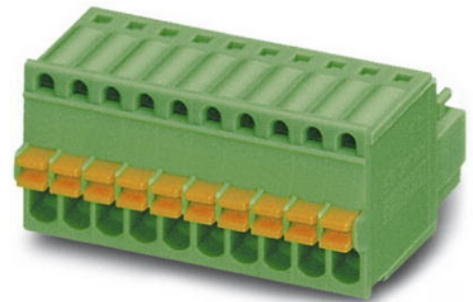

We can also find the relay connectors.

<sup>17</sup>

[https://es.farnell.com/phoenix-contact/fk-mc-0-5-10-st-2-5/plug-libre-muelle-2-5-mm-10-v/dp/1792814?CMP=KNC-GEN-KWL-PDP-High-Aov-phoenix-contact-15-July-22&mckv=\\_dc%7Cpcrid%7C603873204419%7C&gclid=Cj0KCQjw\\_vjWBhD8ARIsAH1mCd4jzLvIJs5K\\_3IEpaW5Anqo3FBLu1TwiPFtyKaiP-rj4LSly67bWoaAuLnEALw\\_wcB](https://es.farnell.com/phoenix-contact/fk-mc-0-5-10-st-2-5/plug-libre-muelle-2-5-mm-10-v/dp/1792814?CMP=KNC-GEN-KWL-PDP-High-Aov-phoenix-contact-15-July-22&mckv=_dc%7Cpcrid%7C603873204419%7C&gclid=Cj0KCQjw_vjWBhD8ARIsAH1mCd4jzLvIJs5K_3IEpaW5Anqo3FBLu1TwiPFtyKaiP-rj4LSly67bWoaAuLnEALw_wcB)

[MCV 1.5/ 2-G-3.81 1803426](#)<sup>18</sup> is the female connector, and [MC 1.5/ 2-ST-3.81, GTIN UPC](#)<sup>19</sup> is the male one. Both are from Phoenix Contact.

<b>Article reference</b>	MCV 1,5/ 2-G-3,81 1803426
<b>Height</b>	12.6 mm
<b>Pitch</b>	3.81 mm
<b>Dimension a</b>	3.81 mm
<b>Pin dimensions</b>	0.8 x 0.8 mm



<b>Article reference</b>	MC 1,5/ 2-ST-3,81 - 1803578
<b>Height</b>	11.1 mm
<b>Pitch</b>	3.81 mm
<b>Dimension a</b>	3.81 mm



<sup>18</sup>

[https://www.tme.eu/es/details/mcv1.5\\_2-g-3.81/bloque-de-bornas-extraibles/phoenix-contact/mcv-1-5-2-g-3-81-1803426/?brutto=1&currency=EUR&gclid=Cj0KCQjw\\_viWBhD8ARIsAH1mCd763F0sGBmfjy5pmZm9dKysA6ePciWt8md8utGsZX1OfLpgsBx4mnoaAo9GEALw\\_wcB](https://www.tme.eu/es/details/mcv1.5_2-g-3.81/bloque-de-bornas-extraibles/phoenix-contact/mcv-1-5-2-g-3-81-1803426/?brutto=1&currency=EUR&gclid=Cj0KCQjw_viWBhD8ARIsAH1mCd763F0sGBmfjy5pmZm9dKysA6ePciWt8md8utGsZX1OfLpgsBx4mnoaAo9GEALw_wcB)

<sup>19</sup>

[https://es.farnell.com/phoenix-contact/1803578/terminal-block-pluggable-2pos/dp/3704907?gclid=Cj0KCQjw\\_viWBhD8ARIsAH1mCd6YjA37NqmaafFBXgbRyGExfAM8qDodVOWZPFysLLQhnVygDn8ufNslaAmgYEALw\\_wcB&mckv=\\_dc%7Cpcrid%7C575710444791%7Cplid%7C%7Ckword%7C%7Cmatch%7C%7Cslid%7C%7Cproduct%7C3704907%7Cpgrid%7C131987845643%7Cptaid%7Cpla-372506228807&CMP=KNC-GES-GEN-SMART-SHOPPING-High-Jan-2022&gross\\_price=true](https://es.farnell.com/phoenix-contact/1803578/terminal-block-pluggable-2pos/dp/3704907?gclid=Cj0KCQjw_viWBhD8ARIsAH1mCd6YjA37NqmaafFBXgbRyGExfAM8qDodVOWZPFysLLQhnVygDn8ufNslaAmgYEALw_wcB&mckv=_dc%7Cpcrid%7C575710444791%7Cplid%7C%7Ckword%7C%7Cmatch%7C%7Cslid%7C%7Cproduct%7C3704907%7Cpgrid%7C131987845643%7Cptaid%7Cpla-372506228807&CMP=KNC-GES-GEN-SMART-SHOPPING-High-Jan-2022&gross_price=true)

## 18 DIN Rail mounting

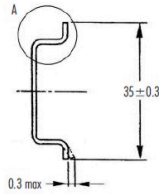
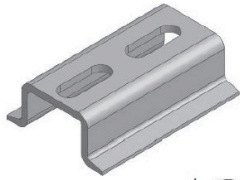

Profilato a cappello TH 35-7,5  
Top hat rail TH 35-7,5

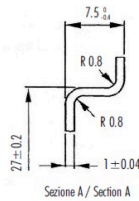

Profilato a cappello TH 35-15  
Top hat rail TH 35-15

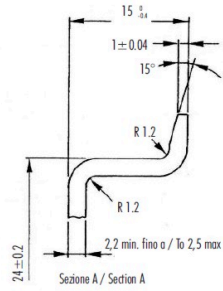

CARATTERISTICHE	METODO	UNITA' DI MISURA	BLENDE PC/ABS	
<b>Meccaniche</b>	Resistenza a trazione allo staccamento	ASTM D638	MPa	68
	Resistenza a trazione a rottura	ASTM D638	MPa	48
	Allungamento a rottura	ASTM D638	%	59
	Modulo in flessione	ASTM D790	MPa	2894
<b>Termiche</b>	Proof Load con intaglio	ISO 180/14	KJ/m <sup>2</sup>	5.5
	Temp. di rammolimento Visc. metodo B	ASTM D1525	°C	114
<b>Fisiche</b>	Temperatura Kiersto 1.81 MPa	ASTM D648	°C	97
	Peso specifico	ASTM D792	g/cm <sup>3</sup>	1.21
	Dist. nello stampo	ASTM D955	%	0.4/0.6
<b>Comportamento alla fiamma</b>	Melt Flow Index 240°C - 98N	ASTM D1238	g/10'	11.1
	Filo Incondens. 3.2 mm	IEC6052.1	°C	V-0 (0.8) 960

Italtronic si riserva il diritto di modificare il materiale con cui realizza i propri prodotti senza obbligo di preavviso.

FEATURES	TEST METHOD	UNITS	BLENDE PC/ABS	
<b>Mechanical test</b>	Resistance to tensile stress at yield	ASTM D638	MPa	68
	Tensile strength	ASTM D638	MPa	48
	Ultimate elongation	ASTM D638	%	59
	Flexing modulus	ASTM D790	MPa	2894
<b>Thermal test</b>	load test notched	ISO 180/14	KJ/m <sup>2</sup>	5.5
	Visc softening temperature method B	ASTM D1525	°C	114
<b>Physical test</b>	Rolling temperature 1.81 MPa	ASTM D648	°C	97
	Specific gravity	ASTM D792	g/cm <sup>3</sup>	1.21
	Mold shrinkage	ASTM D955	%	0.4/0.6
<b>Flame test</b>	Melt Flow Index 240°C - 98N	ASTM D1238	g/10'	11.1
	Self extinguisher (thickness in mm)	IEC6052.1	°C	V-0 (0.8) 960
	Incondensable thread 3.2 mm	IEC6052.1	°C	V-0 (0.8) 960

Italtronic can operate any change of the materials without being obliged to forewarn.

**For optimal operation of the product, it must be located in an electrical cabinet with IK08 mechanical protection. The minimum IP protection degree required is IP56.**

## 19 Installation and Maintenance

### Notes for installation:

- The installation position should be free from the following: dust or oil smoke, conductive dust, corrosive or flammable gas, high temperature, condensation, and rain.
- Besides, vibration and impact also affect the PLC normal operation and shorten its lifespan; electric shock, fire or misact also damages the product. During drilling or wiring, prevent the metal particles or wire segments from falling into the PLC casing, which may cause fire, fault or misact.
- After the PLC installation, clean the ventilation duct to prevent blocking, which may cause bad ventilation, or even fire, faults or misact.
- Do not online connect, plug or unplug cables, which are apt to cause electric shock or damage the circuit. Installation and wire connection must be firm and reliable. Poor connection could cause a misact.
- Use shielded twisted pairs for the I/O of high frequency signal and analog signal to improve system IMS.

The installation environment should be free from dust, oil smoke, conductive particles, corrosive or flammable gases, high temperature, condensation, and rain.

Besides, vibration and impact also affect the PLC normal operation and shorten its lifespan. It is recommended to install the PLC, together with the matching switches and contactors, in a dedicated electric cabinet and keep the cabinet ventilated. If the location has high ambient temperature or heat generating equipment nearby, install forced convection devices on top or sides of the cabinet to avoid over-temperature. During drilling or wiring, prevent the metal particles or wire segments from falling into the PLC casing, which may cause fire, fault or misact. After the PLC installation, clean the ventilation duct to prevent blocking, which may cause bad ventilation, or even fire, faults or misact.

The only way to disconnect the equipment from the electrical network is by removing the connectors that feed the equipment. Once installed in the electrical cabinet it is very important to ensure the power connectors for proper operation.

### Separate the M-Duino Family PLC from heat, high voltage and electrical noise:

Always separate the devices that generate high voltage and high electrical noise from the M-Duino. When configuring the layout of the M-Duino inside your panel, consider the heat-generating devices and locate the electronic-type devices in the cooler areas of your cabinet. Reducing the exposure to a high-temperature environment will extend the operating life of any electronic device. Consider also the routing of the wiring for the devices in the electric cabinet. Avoid placing low-voltage signal wires and communications cables in the same tray with AC power wiring and high energy, rapidly-switched DC wiring.

Provide adequate clearance for cooling and wiring M-Duino. Is designed for natural convection cooling. For proper cooling, you must provide a clearance of at least 25 cm



above and below the devices. Also, allow at least 25 cm of depth between the front of the modules and the inside of the enclosure.

#### Notes for maintenance:

A well-planned and executed maintenance program is essential to the satisfactory operation of solid-state electrical equipment. The kind and frequency of the maintenance operation will vary with the kind and complexity of the equipment as well as with the nature of the operating conditions. Maintenance recommendations of the manufacturer or appropriate product standards should be followed.

The following factors should be considered when formulating a maintenance program:

- Maintenance must be performed by qualified personnel familiar with the construction, operation, and hazards involved with the control.
- Maintenance should be performed with the control out of operation and disconnected from all sources of power.
- Care should be taken when servicing electrostatic sensitive components. The manufacturer's recommendations for these components should be followed.
- Ventilation passages should be kept open. If the equipment depends upon auxiliary cooling, e.g., air, water, or oil, periodic inspection (with filter replacement when necessary) should be made of these systems.
- The means employed for grounding or insulating the equipment from ground should be checked to assure its integrity.
- Accumulations of dust and dirt on all parts, including on semiconductor heat sinks, should be removed according to the manufacturer's instructions, if provided; otherwise, the manufacturer should be consulted. Care must be taken to avoid damaging any delicate components and to avoid displacing dust, dirt, or debris in a way that permits it to enter or settle into parts of the control equipment.
- Enclosures should be inspected for evidence of deterioration. Accumulated dust and dirt should be removed from the top of the enclosures before opening doors or removing covers.
- Certain hazardous materials removed as part of maintenance or repair procedure (e.g. polychlorinated biphenyls (PCBs) found in some liquid filled capacitors) must be disposed of as described in Federal regulations.

#### Safety rules for maintenance personnel

Consider the following steps to follow. A false manoeuvre could be the cause of an accident or material damage.

Do not disassemble or modify the modules. This could lead to breakdowns or malfunctions and could lead to injuries or fire.

- All types of radio communication devices, including mobile phones and personal handy-phone systems (PHS), must be kept more than **25 cm** away from the PLC in all directions. Failure to observe this precaution exposes malfunctions caused by an excess of temperature.
- Disconnect the external power supply of the system (on all phases) before connecting or disconnecting a module. Failure to observe this precaution may cause faults or malfunctions of the module.

- Tighten the screws of the terminal ports and the screws of the connectors within the prescribed tightening torque. Insufficient tightening can lead to loose parts or wires and cause malfunctions. Excessive tightening can damage the screws and / or the module, with the risk of falling, short circuits and malfunctions.
- Before handling a module, dispose of the electrostatic charge accumulated by the human body by touching a suitable conductive object. Failure to observe this precaution may cause faults or malfunctions of the module.

**Repair note:**

If the equipment is suitable to be repaired, it must be verified that the equipment remains in a safe state after repair.

## 20 Revision Table

Revision Number	Date	Changes
0	30/07/2020	First implementation
1	11/08/2020	Added DALI Communication
2	05/10/2022	M-Duino DALI Family User Manual Implementation
3	11/03/2024	Added section 14 "Digital inputs threshold detection"
4	26/09/2024	Added section 3.4 ("Isolation Precautions")
5	03/12/2024	Removed wrong IORef pin reference

About Industrial Shields:

Direction: Camí del Grau, nº25

Zip/Postal Code: 08272

City: Sant Fruitós de Bages (Barcelona)

Country: Spain

Telephone: (+34) 938 760 191 / (+34) 635 693 611

Mail: [industrialshields@industrialshields.com](mailto:industrialshields@industrialshields.com)