

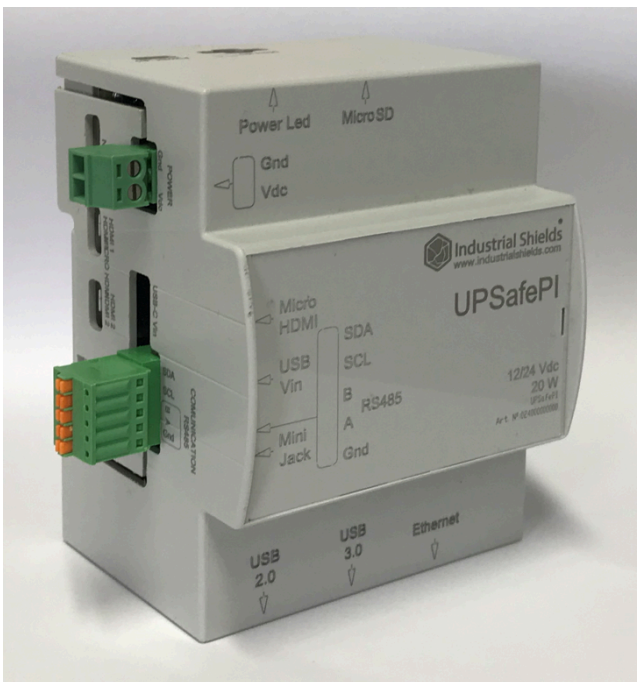

INDUSTRIAL SHIELDS

UPSafePi



UPS Safe Pi:

- Raspberry Pi 4
- UPS & RTC shield
- Enclosure

Industrial Shields

Raspberry Pi UPSafePi

Revised September 2024

Preface

This User Guide has been implemented by Boot & Work, S.L. working under the name Industrial Shields.

Purpose of the manual

The information contained in this manual can be used as a reference to operate, to functions, and to the technical data of the signal modules, power supply modules and interface modules.

Intended Audience

This User Guide is intended for the following audience:

- Persons in charge of introducing automation devices.
- Persons who design automation systems.
- Persons who install or connect automation devices.
- Persons who manage working automation installation

Intended use of Industrial Shields products

Consider the following:

Industrial Shields products should only be used for the cases of application foreseen in the catalogue and the associated technical documentation. If third-party products and components are used, they must have been recommended or approved by Industrial Shields.

The correct and safe operation of the products requires that your transport, storage, installation, assembly, operation and maintenance have been carried out in a correct manner. It must respect the permissible ambient conditions. You should also follow the indications and warnings that appear in the associated documentation.

The product / system dealt with in this documentation should only be handled or manipulated by qualified personnel for the task entrusted and observing what is indicated in the documentation corresponding to it, particularly the safety instructions and warnings included in it. Due to their training and experience, qualified personnel are in a position to recognize risks resulting from the handling or manipulation of such products / systems and to avoid possible hazards.

Disclaimers

Weights and Dimensions

Dimensions and weights are nominal and they are not used for manufacturing purposes, even when tolerances are shown.

Performance Data

The performance data given in this manual is provided as a guide for the user in determining suitability and does not constitute a warranty. It may represent the result of INDUSTRIAL SHIELDS's test conditions, and the users must correlate it to actual application requirements. Actual performance is subject to the INDUSTRIAL SHIELDS Warranty and Limitations of Liability.

Change in Specifications

Product specifications and accessories may be changed at any time based on improvements and other reasons.

It is our practice to change model numbers when features are changed, or published ratings or when significant construction changes are made. However, some specifications of the products may be changed without any notice. When in doubt, special numbers may be assigned to fix or establish key specifications for your application on your request. Please consult with your INDUSTRIAL SHIELDS representative at any time to confirm actual specifications of purchased products

Errors and Omissions

The information in this document has been carefully checked and is believed to be accurate; however, no responsibility is assumed for clerical, typographical, or proofreading errors, or omissions.

These components may only be operated in closed housings or in higher-level control cabinets with protective covers that are closed, and when all of the protective devices are used. These components may only be handled by qualified and trained technical personnel who are knowledgeable and observe all of the safety information and instructions on the components and in the associated technical user documentation. When carrying out a risk assessment of a machine in accordance with the EU Machinery Directive, the machine manufacturer must consider the following residual risks associated with the control and drive components of a PDS.

Table of Contents

1 General Description.....	6
1.1. General Specifications.....	6
1.1.1. Raspberry Pi 4.....	6
1.1.2. UPS & RTC shield.....	7
1.2. Available Communications & Accessories.....	7
1.3. Precautions.....	8
1.3.1. Raspberry Board.....	8
1.3.2. Intended Audience.....	8
1.3.3. General Precautions.....	8
1.3.4. Isolation Precautions.....	8
1.4. Pinout.....	9
1.4.1. UPS & RTC shield.....	9
1.4.2. Raspberry Pi 4.....	9
1.5. Pinout.....	10
1.5.1. Overall device.....	10
1.5.2. UPS & RTC Shield.....	10
1.6. Main parameters.....	11
1.7. Raspberry Pi 4 Pinout Connector.....	11
1.8. UPSafe Pi Serigraphy.....	13
1.8.1. View 1.....	13
1.8.2. View 2.....	13
1.8.3. View 3.....	13
1.8.4. View 4.....	14
1.8.5. View 5.....	14
1.9. Raspberry Pi Connections.....	15
1.10. Unmount/Mount instructions.....	16
1.11. Connectors.....	18
2 Raspberry Pi Software.....	21
2.1 Standard image installation.....	21
2.2 Enable the controlled shutdown on your Raspberry Pi.....	21
2.3 How to execute commands before the Power Off process.....	22
2.4 Enable the RTC functionality on your Raspberry Pi.....	23
2.5 Enable the RS-485 functionality on your Raspberry Pi.....	23
3 Revision Table.....	25



INDUSTRIAL SHIELDS

1 General Description

This device consists of a Raspberry Pi 4 attached to a UPS & RTC shield, all in a perfect fitted enclosure.

1.1. General Specifications

1.1.1. Raspberry Pi 4

Processor	Broadcom BCM2711, quad-core Cortex-A72 (ARM v8) 64-bit SoC @ 1.5GHz
Memory	2GB, 4GB or 8GB LPDDR4 (depending on model)
Connectivity	2.4 GHz and 5.0 GHz IEEE 802.11b/g/n/ac wireless LAN, Bluetooth 5.0, BLE Gigabit Ethernet 2 × USB 3.0 ports 2 × USB 2.0 ports.
GPIO	Standard 40-pin GPIO header (fully backwards-compatible with previous boards)
Video & Sound	2 × micro HDMI ports (up to 4Kp60 supported) 2-lane MIPI DSI display port 2-lane MIPI CSI camera port 4-pole stereo audio and composite video port
Multimedia	H.265 (4Kp60 decode); H.264 (1080p60 decode, 1080p30 encode); OpenGL ES 3.1 graphics, Vulkan 1.0
SD card support	Micro SD card slot for loading operating system and data storage
Input Power	5Vdc via USB-C connector (minimum 3A*) 5Vdc via GPIO header (minimum 3A*) Power over Ethernet (PoE)–enabled (requires separate PoE HAT)
Environment	Operating temperature 0–50°C

*A good quality 2.5A power supply can be used if downstream USB peripherals consume less than 500mA in total.

1.1.2. UPS & RTC shield

- Plug & Play UPS Smart Shield and Real Time Clock (RTC) for Raspberry Pi
- Avoid any SD corruption issue
- 12Vdc or 24Vdc
- With RS485 protocol available
- Compatible with all Raspberry Pi 2, 3, 4 & all Raspberry Pi B models
- Recharge Time: Less than 1 minute
- Reconnecting time: Less than 20 seconds
- With reboot button (or the possibility to add an external one)
- Vin ESD protection

Operational Voltage	Current	Max. Current	Super Capacitors	Certificate	Possible MCU Connections	RTC
12 or 24Vdc (Antipolarity + Filter)	3 A (Autoprotected by chip)	3,5 A	x2 (25F) 2.7V	CE, RoHs	-Raspberry Pi 2 & 2B -Raspberry Pi 3 & 3B -Raspberry Pi 4B	DS3231 Coin cell: CR1220

1.2. Available Communications & Accessories

- RS-485 Port
- ICSP Connector
- I2C (3,3Vdc)
- USB Type-C (Power Only)
- RTC
- Raspberry Pi Connector

1.3. Precautions

Read this manual before attempting to use the RASPBERRY Pi UPSafePi and follow its descriptions for reference during operation.

1.3.1. Raspberry Board

The RASPBERRY Pi UPSafePi includes a Raspberry Pi 4 Board as controller.

1.3.2. Intended Audience

This manual is intended for technicians, which must have knowledge on electrical systems.

1.3.3. General Precautions

The user must operate RASPBERRY Pi UPSafePi according to the performance specifications described in this manual.

Before using the RASPBERRY Pi UPSafePi under different conditions from what has been specified in this manual or integrating into nuclear control systems, railroad systems, aviation systems, vehicles, combustion systems, medical equipment, amusement machines, safety equipment and other systems, machines, and equipment that may have a serious influence on lives and property if used improperly, consult your INDUSTRIAL SHIELDS representative. Ensure that the rating and performance characteristics of the RASPBERRY Pi UPSafePi are sufficient for the systems, machines, and equipment, and be sure to provide the systems, machines, and equipment double safety mechanisms. This manual provides information for programming and operating the RASPBERRY Pi UPSafePi.

1.3.4. Isolation Precautions

Description:

This equipment does **not include galvanic isolation between the grounds** of the different systems. This means that if an external device or sensor that shares the same ground reference (GND) with the system is connected, any potential difference between these grounds could damage the connected components. To avoid issues with interference, ground loops, or damage to external equipment, ensure that all connected devices share the same ground reference or use systems with appropriate isolation.

Recommendations:

- **Connection Review:** Verify that all ground connections are properly made and that there are no significant potential differences between them.
- **Use of Isolation:** Consider using galvanic isolators or isolation transformers if it is necessary to connect equipment with different ground references.

1.4. Pinout

1.4.1. UPS & RTC shield

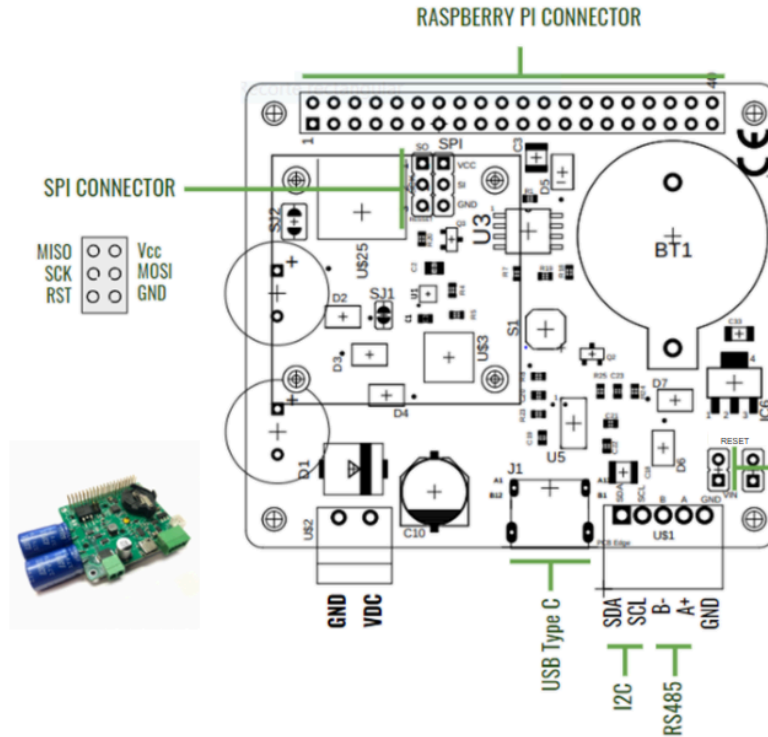

1.4.2. Raspberry Pi 4

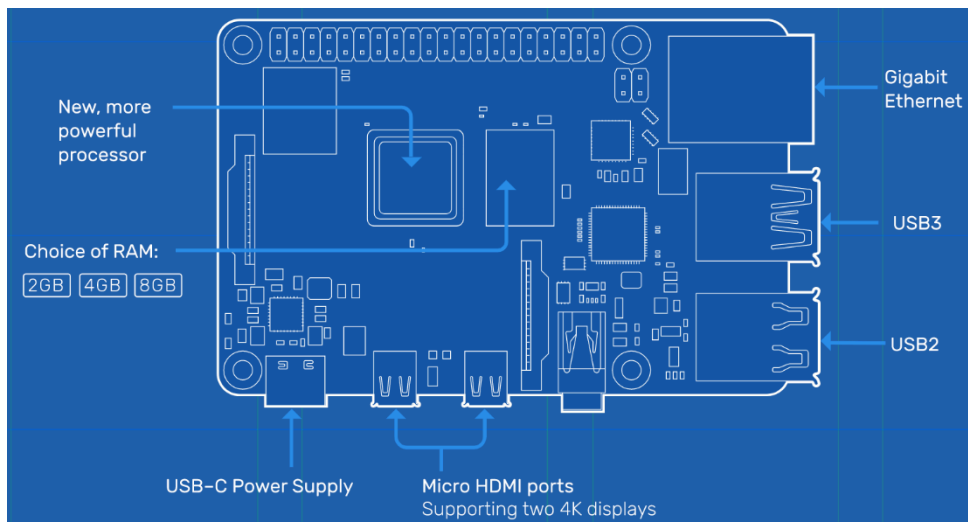

1.5. Pinout

1.5.1. Overall device

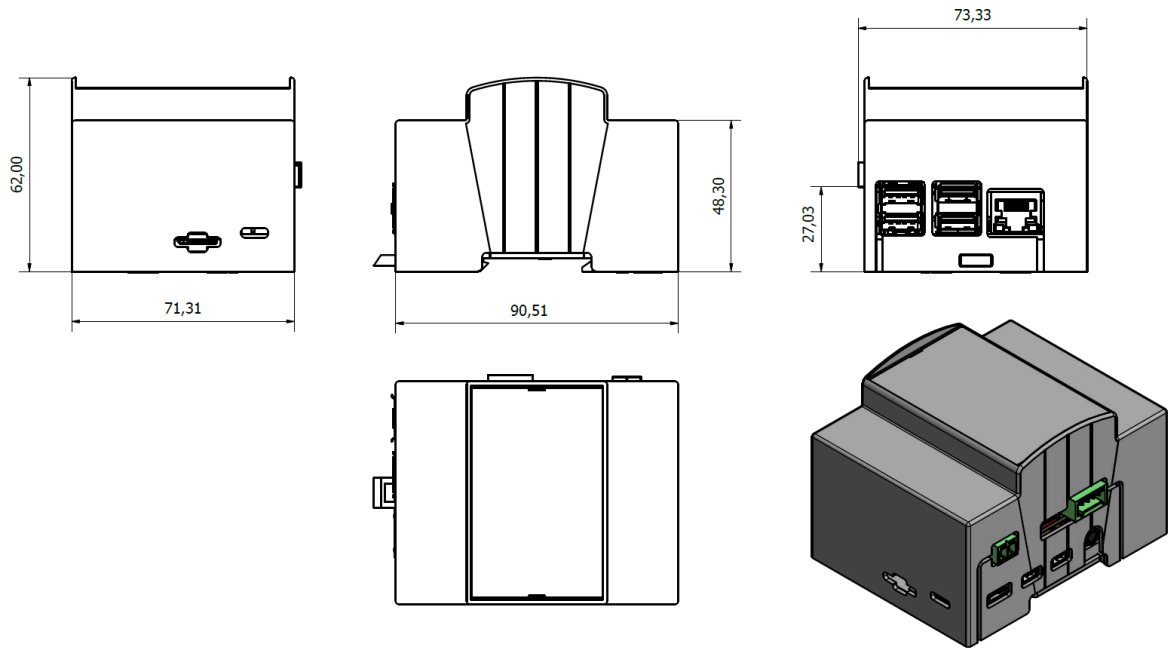

1.5.2. UPS & RTC Shield

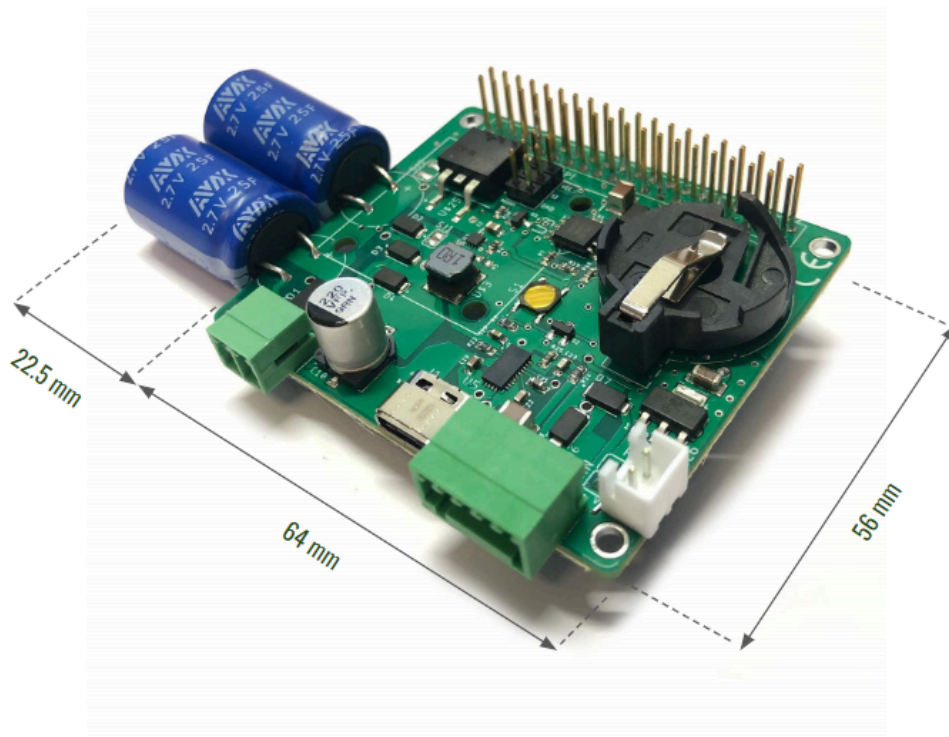

*The capacitors will be assembled in a different way.

1.6. Main parameters

Parameter	Value	Conditions
Input parameters		
Input voltage (screw terminal)	7Vdc ... 28Vdc	At screw terminal
Input voltage (USB terminal)	5Vdc	USB terminal
Average input current	0.5A	Charge mode + RPi Booting at Vin = 24V
Output parameters		
Output voltage range	4.75Vdc ... 5.5Vdc	
Output current range	0Aavg ... 2Aavg	
Output ripple	20mVpp	Raspberry Pi as a web server
Control parameters		
Pin 16 (GPIO23)	3.3Vdc – 5Vdc (Inputs maximum voltage)	
Pin 13 (GPIO27)	3.3Vdc – 5Vdc (Outputs maximum voltage)	

1.7. Raspberry Pi 4 Pinout Connector

	NC	1	2	Vin	
SDA	GPIO2	3	4	Vin	
SCL	GPIO3	5	6	GND	
	NC	7	8	GPIO14	TXD
	GND	9	10	GPIO15	RXD
	GPIO17	11	12	NC	
DE	GPIO27	13	14	GND	
	NC	15	16	GPIO23	UPS Control from RASPBerry
	NC	17	18	GPIO24	UPS Control to RASPBerry
	NC	19	20	GND	
	NC	21	22	NC	
	NC	23	24	NC	
	GND	25	26	NC	
	NC	27	28	NC	
	NC	29	30	GND	
	NC	31	32	NC	
	NC	33	34	GND	
	NC	35	36	NC	
	NC	37	38	NC	
	GND	39	40	NC	

I2C
Serial TTL
UPS
RS485

- GPIO24 (Raspberry's 18 pin) is used by UPS to report if an emergency power-off is needed. If the UPS shield detects that the external power supply has been lost, this pin is going to be connected to GND. In the opposite case, this pin is not going to be connected. Because of this, it is recommended to configure this pin with a pull-up software.
- GPIO23 (Raspberry's 16 pin) is used to report a finished saving process. If the system fails, the UPS shield will maintain the power supply till it receives a low logic value from this pin. If this pin is not connected, in the case of a failure the UPS shield will provide power till the capacitors run out of energy.
- GPIO27 (Raspberry's 13 pin) is the RS-485 half duplex control. The transmission will be enabled with a positive logical value. The reception will be enabled with a negative logical value.
- The reset white connector must have a normally open push button and, when it is pushed, the power supply is going to be removed from the Raspberry. This job can be equally done pushing the reset button in the shield.
- **CAUTION:** This shield is used to discharge the capacitors but, when they are fully charged, it is very important to ensure that no short-circuits will happen, as it may break the shield.

NOTE: If using Raspberry Pi 2 or Raspberry Pi 2 model B, consider the following information:

- GPIO27 is GPIO2 on a Raspberry Pi 2 or Raspberry Pi 2 B model.
- GPIO2 & GPIO3 are GPIO8 & GPIO9 respectively on a Raspberry Pi 2 or Raspberry Pi 2 B model.
- GPIO23 & GPIO24 are GPIO4 & GPIO5, respectively on a Raspberry Pi 2 or Raspberry Pi 2 B model.

1.8. UPSafe Pi Serigraphy

1.8.1. View 1

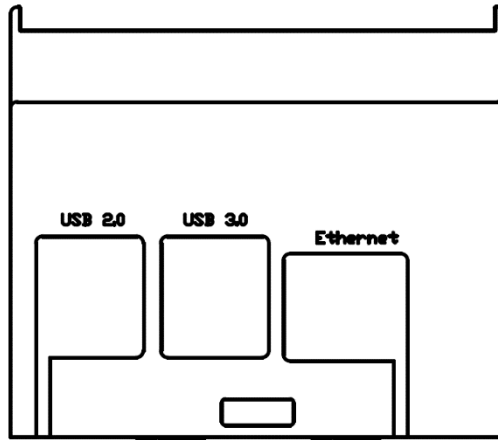

1.8.2. View 2

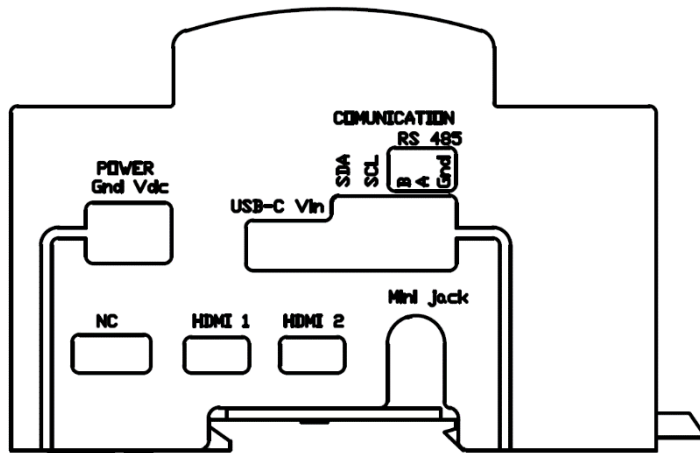

1.8.3. View 3

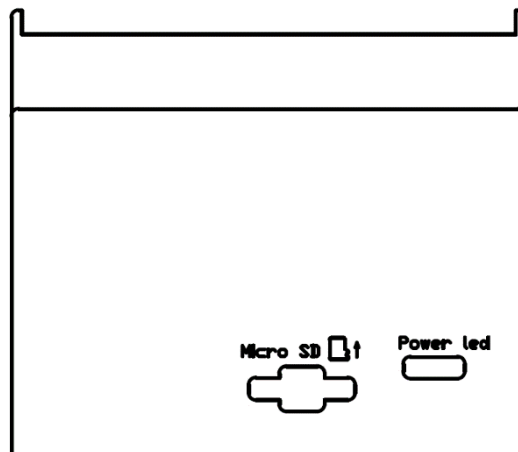

1.8.4. View 4

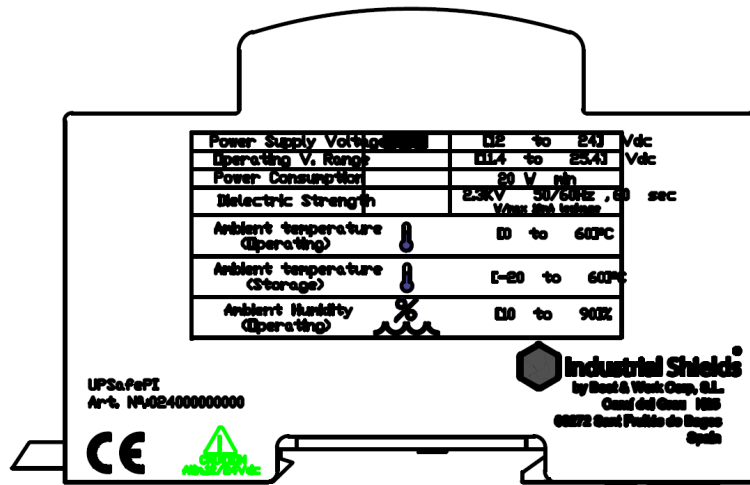

1.8.5. View 5

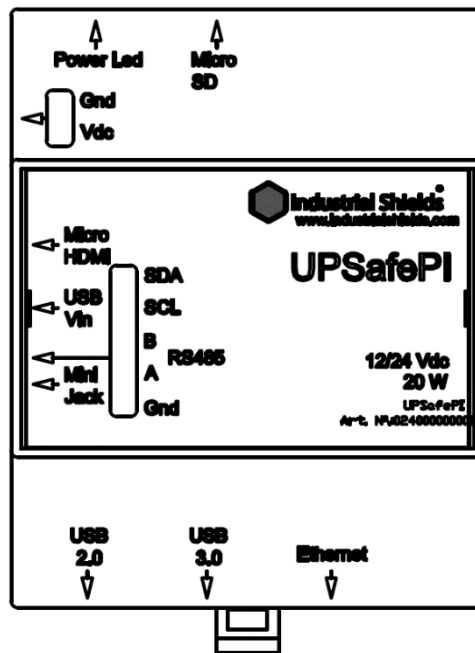

1.9. Raspberry Pi Connections

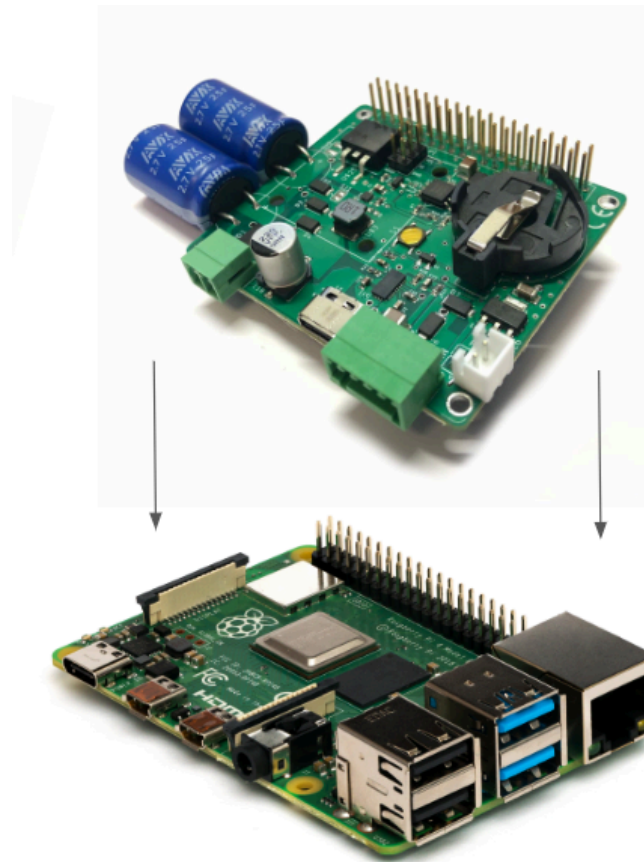

1.10. Unmount/Mount instructions

The device must be unmounted to place the Raspberry within the UPS shield (if required) or to access the cell coin slot.

The steps to unmount it are the following ones:

- Carefully, push with the fingers where the blue arrow is located and push with a screwdriver (or screw/unscrew if required) where the red arrow is located. Be delicate with the spots pointed with the alert sign. Remember to remove all the connectors and the microSD card to mount/unmount the device and place them again when the process is finished.

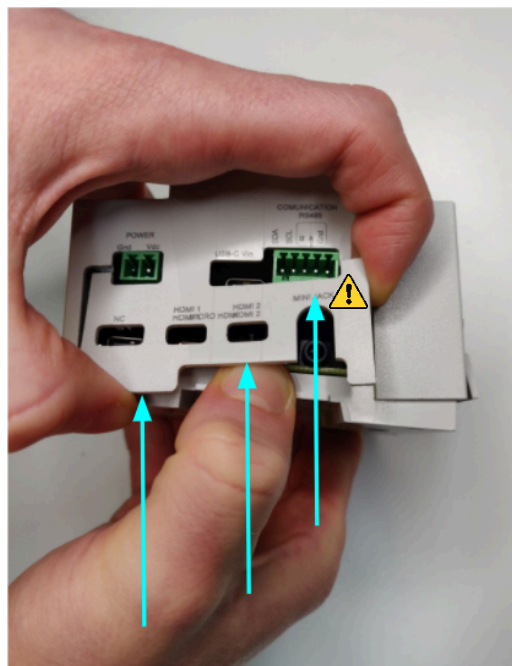
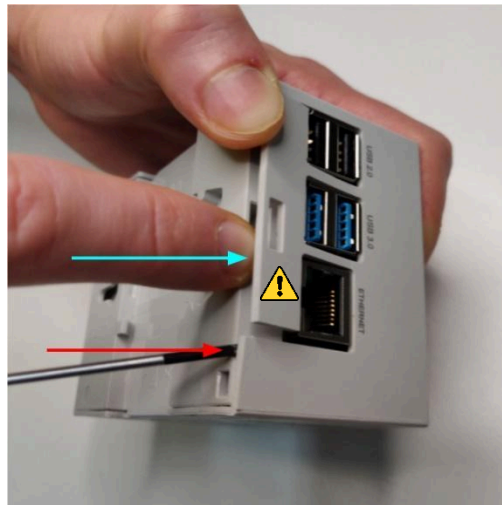

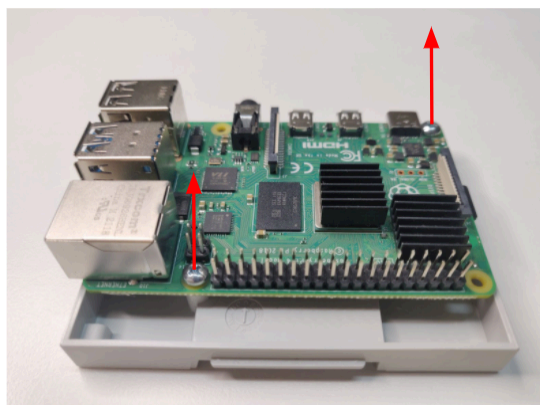
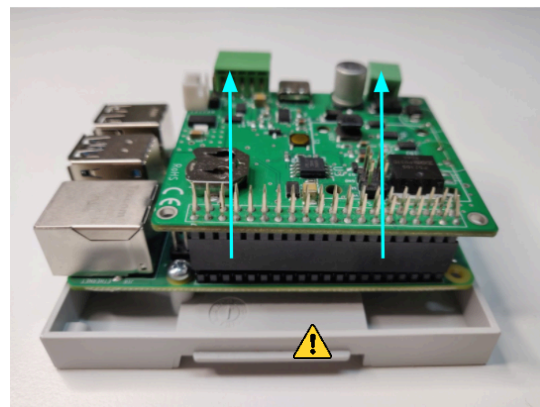
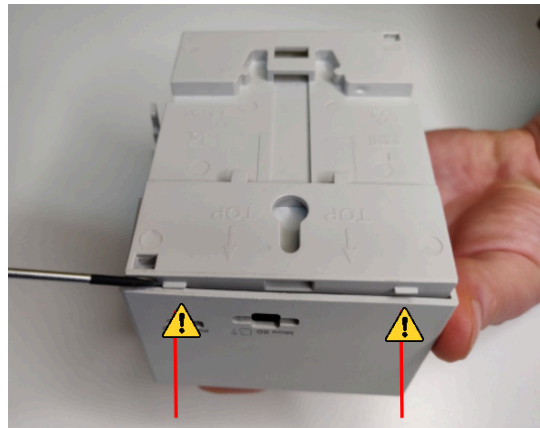

- The steps to mount it are the same but inversely (be careful with the plastic tabs and make sure that everything is placed the right way).

1.11. Connectors

- Power connector:

SKU: 15EDGRC-3.81-02P-14-00A(H)

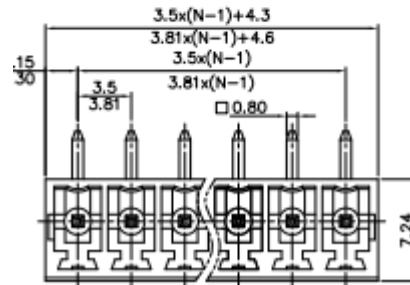
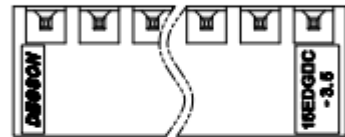
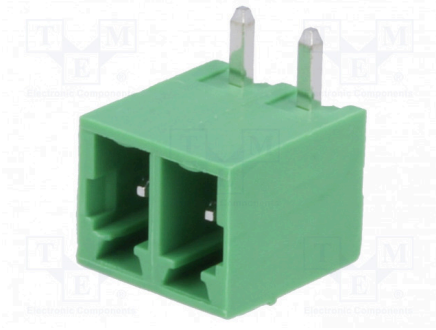

- Communications connector:

SKU: 15EDGKD-2.5-XXP-1Y-00A(H)

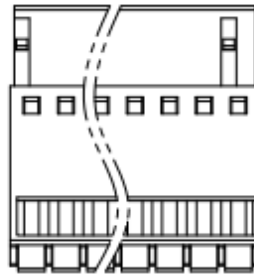
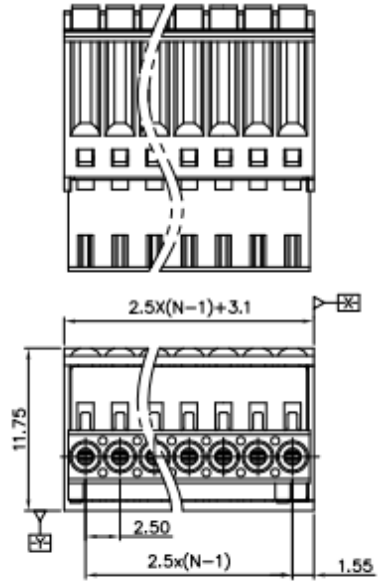

- Reset connector:

SKU: B2B-XH-A (LF)(SN)



Shape A

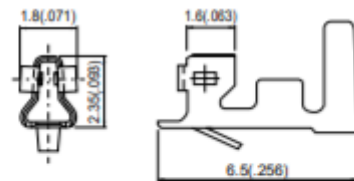

Shape B

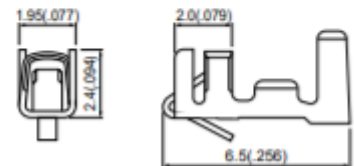

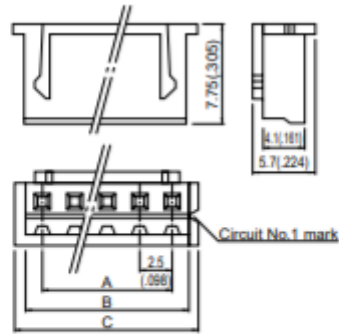

Plugged up
(2 circuits 10.0mm(.394") pitch)

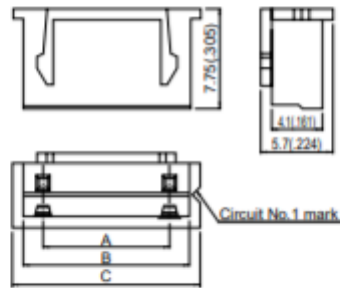

(6 circuits 5.0mm(.197") pitch)

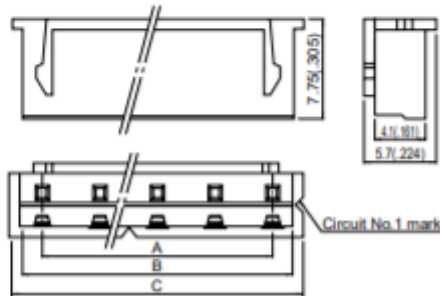

2 Raspberry Pi Software

To start working with the UPS on your Raspberry Pi module, you need to download the “rpishutdown” and “rpishutdown.service” files provided on this [link](#), and perform a simple installation on the OS image, which must be installed first.

2.1 Standard image installation

Raspberry must be used with an SD card inserted in the available slot which has a correct image installed. By default, the SD card is not provided. You will need to acquire one and install an appropriate OS image. The most used and recommended one is Raspberry Pi OS, previously known as Raspbian.

However, in case you want to install another operating system compatible with Raspberry Pi 4B it can be done, but keep in mind that all the services, scripts and executables must be added to the new image to set up the board features (the additional communications, the internal UPS, etc.).

These are the steps to install a fresh Raspberry Pi OS image:

1. Download the Raspberry Pi Imager from this URL: <https://www.raspberrypi.org/software/>
2. Download an operating system image from Raspberry Pi. All the operating system images available here: <https://www.raspberrypi.org/software/operating-systems/>
3. Take your microSD card with an adapter for your PC, and write the image using the Raspberry Pi Imager.
4. Once the process ends, you can introduce the microSD card in your Raspberry PLC.

2.2 Enable the controlled shutdown on your Raspberry Pi

The Raspberry based PLCs can perform a controlled shutdown once the UPS detects that the main power supply has been cut. This ensures all active processes are ended and the SD card image and files are protected.

To enable the controlled shutdown on the Raspberry Pi, follow these steps:

1. **Modify the configuration file:** The process is now managed using device tree overlays. Add the following two lines to the `/boot/firmware/config.txt` file:

```
dtoverlay=gpio-poweroff,gpiopin=23,active_low  
dtoverlay=gpio-shutdown,gpio_pin=24,gpio_pull=up
```

- The `gpio-poweroff` overlay ensures the system powers off gracefully using GPIO pin 23.
- The `gpio-shutdown` overlay detects when the system should shut down using GPIO pin 24.

2. **Save and reboot:** After editing and saving the file, reboot the Raspberry Pi to apply the changes.

The system will now perform a controlled shutdown when the main power is lost, ensuring the protection of data and processes.

2.3 How to execute commands before the Power Off process

To execute specific commands before the system powers off, follow these steps:

1. **Create the necessary directory:** Create the required directory to store the pre-poweroff hooks:

```
sudo mkdir -p /etc/rpishutdown/hooks
```

2. **Download the service file and hook script:** Fetch the required files for the pre-poweroff service and the check script:

```
sudo curl -L
https://apps.industrialshields.com/main/rpi_experimental/rpiplc/rpishutd
own-pre-poweroff.service \
  -o /lib/systemd/system/rpishutdown-pre-poweroff.service
sudo curl -L
https://apps.industrialshields.com/main/rpi_experimental/rpiplc/check-pr
e-poweroff-hook.sh \
  -o /etc/rpishutdown/hooks/check-pre-poweroff
```

Any type of file (Bash Scripts, Python, C++, etc.) can be executed, but the most important thing is that the file must be called “pre-poweroff” without any extension (and you must indicate the file type with the corresponding Shebang). The script execution time cannot surpass ~6 seconds, as it is the Raspberry’s Power Off period.

3. **Grant execution permissions:** Make the pre-poweroff script executable:

```
sudo chmod ugo+x /etc/rpishutdown/hooks/check-pre-poweroff
```

4. **Enable and start the pre-poweroff service:** Reload the systemd daemon and enable the new service:

```
sudo systemctl daemon-reload
sudo systemctl enable rpishutdown-pre-poweroff
sudo systemctl start rpishutdown-pre-poweroff
```

This setup ensures that any custom commands in the check-pre-poweroff script will be executed before the system powers off.

2.4 Enable the RTC functionality on your Raspberry Pi

To enable the RTC functionalities, the steps to follow are:

1. **Update your system:** Make sure your system has the latest updates by running:

```
sudo apt-get update
sudo apt-get -y upgrade
```

2. **Enable I2C on the Raspberry Pi:** Open the configuration file based on your system version:
 - For Bullseye: `/boot/config.txt`
 - For Bookworm or later: `/boot/firmware/config.txt`

Uncomment the following line if it's commented:

```
dtoverlay=i2c_arm=on
```

3. **Enable the RTC overlay:** Add the following line at the end of the file, after the `[all]` section:

```
dtoverlay=i2c-rtc,ds3231
```

4. **Restart the device:** Save the changes and reboot the system to apply the configuration.

2.5 Enable the RS-485 functionality on your Raspberry Pi

The UPS Shield module contains a 2-wire RS-485 (or RS-422) transceiver. The transceiver is driven by the Raspberry Pi UART interface on the GPIO14 and GPIO15 pins. We send and receive data by `/dev/ttyS0`.

- In order to ensure you have got the latest updates you should run the following commands:

```
sudo apt-get update
sudo apt-get -y upgrade
```

- At the end of the `/boot/config.txt` file, after the `[all]` statement, introduce this line:

```
enable_uart=1
```

The following table includes the RS-485 port requirements:

Parameter	Value	Conditions
RS-485 Interface Communication Type	2-wire, half duplex	Transceiver chip ISL8483E
RX/TX direction control	Controlled by GPIO24	Diver enabled by a low TX data bit Driver disabled 25 μ s after the end of a low TX data bit
Failsafe biasing	390R to GND 390R to 5V	
Line Termination	120R	390R//220R//390R+2*10R
Protection	ESD to +/- 15 kV	No Surge/Burst protection
Echo-feature	RX always enabled TX enabled at data	Optional
Data transmission speed	0...250kbps	25 μ s transmission pause between TX and RX required

3 Revision Table

Revision Number	Date	Changes
0	28/12/2021	First implementation
1	25/07/2023	Minor changes
2	03/09/2024	Improved text and formatting
3	05/09/2024	Updated "Raspberry Pi Software" section
4	27/09/2024	Added section 1.3 ("Precautions")

About Industrial Shields:

Direction: Camí del Grau, 25

Zip/Postal Code: 08272

City: Sant Fruitós de Bages (Barcelona)

Country: Spain

Telephone: (+34) 938 760 191 / (+34) 635 693 611

Mail: industrialshields@industrialshields.com