

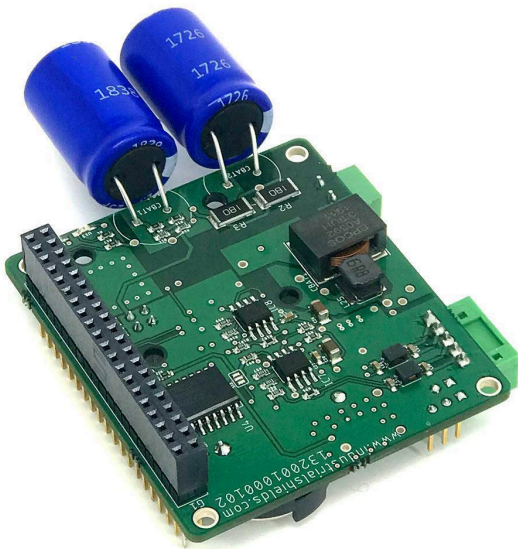

INDUSTRIAL SHIELDS

Raspberry Pi UPS & RTC Shield



- Plug & Play UPS Smart Shield and Real Time Clock (RTC) for Raspberry Pi
- Avoid any SD corruption issue
- 12Vdc or 24Vdc
- With RS-485 protocol available
- Compatible with Tinkerboard. All Raspberry Pi 2, 3, 4 & all Raspberry Pi B models
- Recharge Time: Less than 1 minute
- Reconnecting time: Less than 20 seconds
- With reboot button (or the possibility to add an external one)

Industrial Shields

Raspberry Pi UPS & RTC Shield

Revised September 2024

Preface

This User Guide has been implemented by Boot & Work, S.L. working under the name Industrial Shields.

Purpose of the manual

The information contained in this manual can be used as a reference to operating, to functions, and to the technical data of the signal modules, power supply modules and interface modules.

Intended Audience

This User Guide is intended for the following audience:

- Persons in charge of introducing automation devices.
- Persons who design automation systems.
- Persons who install or connect automation devices.
- Persons who manage working automation installation.

Intended use of Industrial Shields products

Consider the following:

Industrial Shields products should only be used for the cases of application foreseen in the catalogue and the associated technical documentation. If third-party products and components are used, they must have been recommended or approved by Industrial Shields.

The correct and safe operation of the products requires that your transport, storage, installation, assembly, operation and maintenance have been carried out in a correct manner. It must respect the permissible ambient conditions. You should also follow the indications and warnings that appear in the associated documentation.

The product / system dealt with in this documentation should only be handled or manipulated by qualified personnel for the task entrusted and observing what is indicated in the documentation corresponding to it, particularly the safety instructions and warnings included in it. Due to their training and experience, qualified personnel are in a position to recognize risks resulting from the handling or manipulation of such products / systems and to avoid possible hazards.

Disclaimers

Weights and Dimensions

Dimensions and weights are nominal and they are not used for manufacturing purposes, even when tolerances are shown.

Performance Data

The performance data given in this manual is provided as a guide for the user in determining suitability and does not constitute a warranty. It may represent the result of INDUSTRIAL SHIELDS's test conditions, and the users must correlate it to actual application requirements. Actual performance is subject to the INDUSTRIAL SHIELDS Warranty and limitations of Liability.

Change in Specifications

Product specifications and accessories may be changed at any time based on improvements and other reasons.

It is our practice to change model numbers when features are changed, or published ratings or when significant construction changes are made. However, some specifications of the products may be changed without any notice. When in doubt, special numbers may be assigned to fix or establish key specifications for your

application on your request. Please consult with your INDUSTRIAL SHIELDS representative at any time to confirm actual specifications of purchased products.

Errors and Omissions

The information in this document has been carefully checked and is believed to be accurate; however, no responsibility is assumed for clerical, typographical, or proofreading errors, or omissions.

These components may only be operated in closed housings or in higher-level control cabinets with protective covers that are closed, and when all of the protective devices are used. These components may only be handled by qualified and trained technical personnel who are knowledgeable and observe all of the safety information and instructions on the components and in the associated technical user documentation. When carrying out a risk assessment of a machine in accordance with the EU Machinery Directive, the machine manufacturer must consider the following residual risks associated with the control and drive components of a PDS.

1. Unintentional movements of driven machine components during commissioning, operation, maintenance, and repairs caused by, for example: – Hardware defects and/or software errors in the sensors, controllers, actuators, and connection technology – Response times of the controller and drive – Operating and/or ambient conditions not within the scope of the specification – Condensation / conductive contamination – Parameterization, programming, cabling, and installation errors – Use of radio devices / cellular phones in the immediate vicinity of the controller – External influences / damage.
2. Exceptional temperatures as well as emissions of noise, particles, or gas caused by, for example: – Component malfunctions – Software errors – Operating and/or ambient conditions not within the scope of the specification – External influences / damage.
3. Hazardous shock voltages caused by, for example: – Component malfunctions – Influence of electrostatic charging – Induction of voltages in moving motors – Operating and/or ambient conditions not within the scope of the specification – Condensation / conductive contamination – External influences / damage
4. Electrical, magnetic and electromagnetic fields generated in operation that can pose a risk to people with a pacemaker, implants or metal replacement joints, etc. if they are too close.
5. Release of environmental pollutants or emissions as a result of improper operation of the system and/or failure to dispose of components safely and correctly.

Table of Contents

1 General Description.....	6
1.1. General Specifications.....	6
1.2. Available Communications & Accessories.....	6
1.3. Precautions.....	7
1.3.1. Raspberry Board.....	7
1.3.2. Intended Audience.....	7
1.3.3. General Precautions.....	7
1.3.4. Isolation Precautions.....	7
1.4. UPS & RTC Shield Pinout.....	8
1.5. Mechanical dimensions.....	8
1.6. Main parameters.....	9
1.7. Raspberry Pi 3 Pinout Connector.....	9
1.8. Raspberry Pi Connections.....	11
1.9. Connectors.....	12
2 Raspberry Pi Connections.....	14
2.1 Enable the controlled shutdown on your Raspberry Pi.....	14
2.2 Enable the RTC functionality on your Raspberry Pi.....	15
2.3 Enable the RS-485 functionality on your Raspberry Pi.....	15
3 Revision table.....	17



INDUSTRIAL SHIELDS

1 General Description

1.1. General Specifications

Operational Voltage	Current	Max. Current	Super Capacitors	Certificate	Possible MCU Connections	RTC
12 or 24Vdc (Antipolarity + Filter)	3 A (Autoprotected by chip)	3,5 A	x2 (25F)	CE, RoHs	-Raspberry Pi 2 & 2B -Raspberry Pi 3 & 3B -Raspberry Pi 4B -Tinkerboard (ASUS)	DS3231 Coin cell : CR2032

1.2. Available Communications & Accessories

- RS-485 Port
- ICSP Connector
- I2C (3,3Vdc)
- USB Type-C (Power Only)
- RTC
- Raspberry Pi Connectors
- Possibility of connecting a 5Vdc fan

1.3. Precautions

Read this manual before attempting to use the RASPBERRY Pi UPS & RTC Shield and follow its descriptions for reference during operation.

1.3.1. Raspberry Board

The RASPBERRY Pi UPS & RTC Shield includes a Raspberry Pi 4 Board as controller.

1.3.2. Intended Audience

This manual is intended for technicians, which must have knowledge on electrical systems.

1.3.3. General Precautions

The user must operate Raspberry Pi UPS & RTC Shield according to the performance specifications described in this manual.

Before using the RASPBERRY Pi UPS & RTC Shield under different conditions from what has been specified in this manual or integrating into nuclear control systems, railroad systems, aviation systems, vehicles, combustion systems, medical equipment, amusement machines, safety equipment and other systems, machines, and equipment that may have a serious influence on lives and property if used improperly, consult your INDUSTRIAL SHIELDS representative. Ensure that the rating and performance characteristics of the Raspberry Pi UPS & RTC Shield are sufficient for the systems, machines, and equipment, and be sure to provide the systems, machines, and equipment double safety mechanisms. This manual provides information for programming and operating the Raspberry Pi UPS & RTC Shield.

1.3.4. Isolation Precautions

Description:

This equipment does **not include galvanic isolation between the grounds** of the different systems. This means that if an external device or sensor that shares the same ground reference (GND) with the system is connected, any potential difference between these grounds could damage the connected components. To avoid issues with interference, ground loops, or damage to external equipment, ensure that all connected devices share the same ground reference or use systems with appropriate isolation.

Recommendations:

- **Connection Review:** Verify that all ground connections are properly made and that there are no significant potential differences between them.
- **Use of Isolation:** Consider using galvanic isolators or isolation transformers if it is necessary to connect equipment with different ground references.

1.4. UPS & RTC Shield Pinout

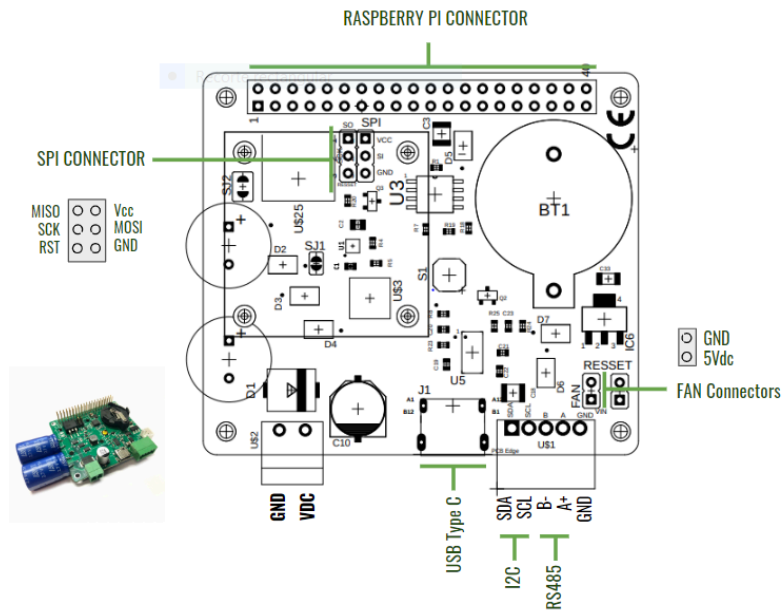

1.5. Mechanical dimensions

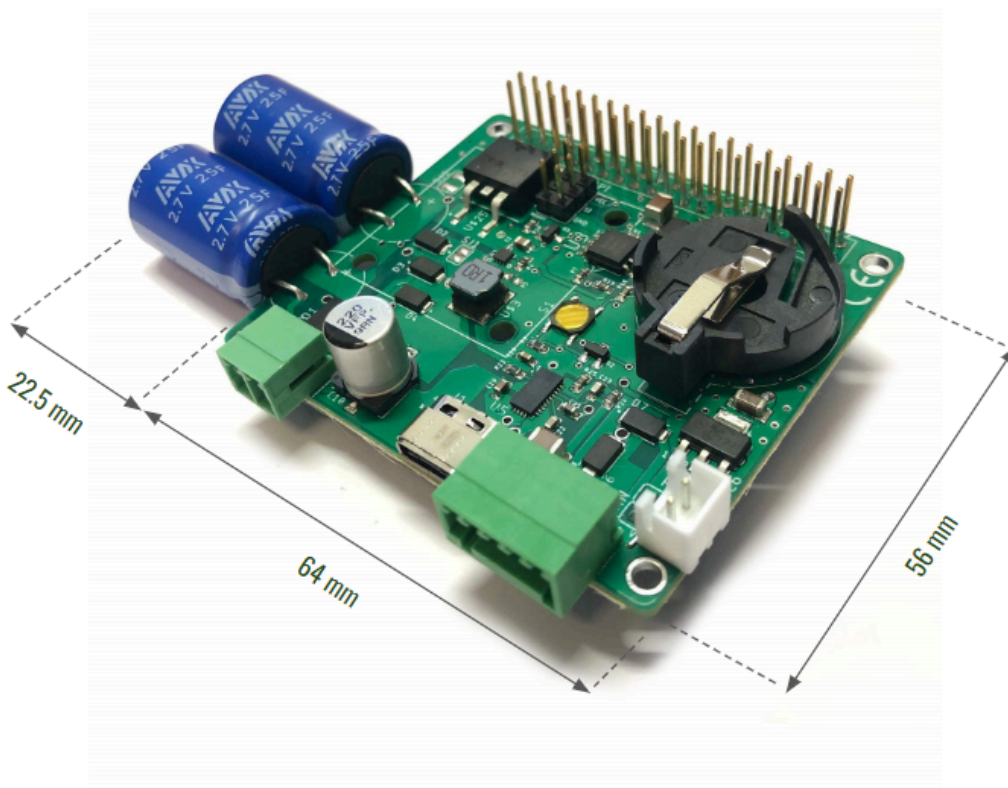

1.6. Main parameters

Parameter	Value	Conditions
Input parameters		
Input voltage (screw terminal)	7Vdc ... 28Vdc	At screw terminal
Input voltage (USB terminal)	5Vdc	USB terminal
Average input current	0.5A	Charge mode + RPI3 Booting at Vin = 24V
Output parameters		
Output voltage range	4.75Vdc ... 5.5Vdc	
Output current range	0Aavg ... 2Aavg	
Output ripple	20mVpp	Raspberry Pi4 as a web server
Fan voltage	4.75Vdc – 5.5Vdc	
Control parameters		
Pin 16 (GPIO23)	3.3Vdc – 5Vdc (Inputs maximum voltage)	
Pin 13 (GPIO27)	3.3Vdc – 5Vdc (Outputs maximum voltage)	

1.7. Raspberry Pi 3 Pinout Connector

	NC	1	2	Vin	
SDA	GPIO2	3	4	Vin	
SCL	GPIO3	5	6	GND	
	NC	7	8	GPIO14	TXD
	GND	9	10	GPIO15	RXD
	GPIO17	11	12	NC	
DE	GPIO27	13	14	GND	
	NC	15	16	GPIO23	UPS Control from RASPBERY
	NC	17	18	GPIO24	UPS Control to RASPBERY
	NC	119	20	GND	
	NC	21	22	NC	
	NC	23	24	NC	
	GND	25	26	NC	
	NC	27	28	NC	
	NC	29	30	GND	
	NC	31	32	NC	
	NC	33	34	GND	
	NC	35	36	NC	
	NC	37	38	NC	
	GND	39	40	NC	

I2C
Serial TTL
RS485
UPS

- GPIO24 (Raspberry's 18 pin) is used by UPS to report if an emergency power-off is needed. If the UPS shield detects that the external power supply has been lost, this pin is going to be connected to GND. In the opposite case, this pin is not going to be connected. Because of this, it is recommended to configure this pin with a pull-up software.
- GPIO23 (Raspberry's 16 pin) is used to report a finished saving process. If the system fails, the UPS shield will maintain the power supply till it receives a low logic value from this pin. If this pin is not connected, the UPS shield will manage that, in the case of a failure, it must provide power till the capacitors run out of energy.
- GPIO27 (Raspberry's 13 pin) is the 485 half duplex control. The transmission will be enabled with a positive logical value. The reception will be enabled with a negative logical value.
- The reset white connector must have a normally open push button and, when it is pushed, the power supply is going to be removed from the Raspberry. This job can be equally done pushing the reset button in the shield.
- Just below the shield, there is a connector to provide power to a fan (if it is needed). There are through-holes to put support columns and a fan.
- **CAUTION:** This shield is used to discharge the capacitors but, when they are fully charged, it is very important to ensure that any short-circuit happens because it may break the shield.

NOTE: If using Raspberry Pi 2 or Raspberry Pi 2 model B, consider the following information:

- GPIO27 is GPIO2 on a Raspberry Pi 2 or Raspberry Pi 2 B model.
- GPIO2 & GPIO3 are GPIO8 & GPIO9 respectively on a Raspberry Pi 2 or Raspberry Pi 2 B model.
- GPIO23 & GPIO24 are GPIO4 & GPIO5, respectively on a Raspberry Pi 2 or Raspberry Pi 2 B model.

1.8. Raspberry Pi Connections

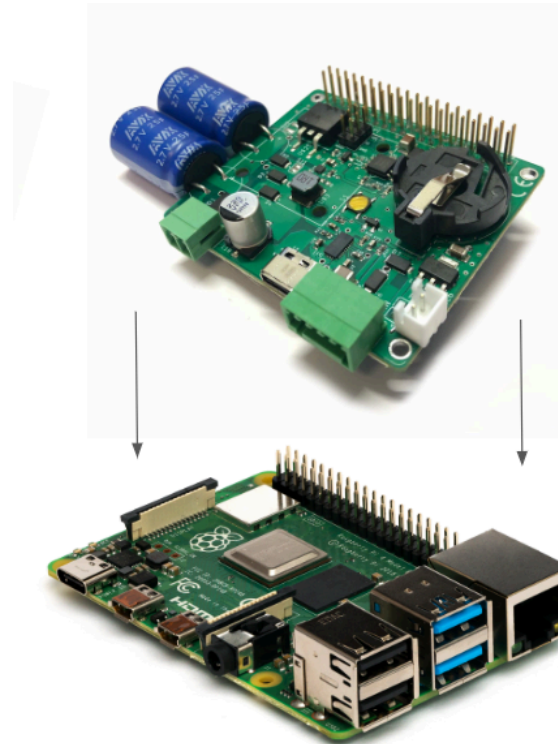

1.9. Connectors

- Power connector:

SKU: 15EDGRC-3.81-02P-14-00A(H)

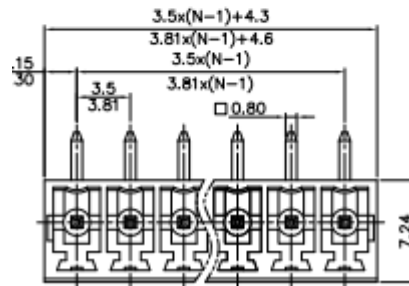
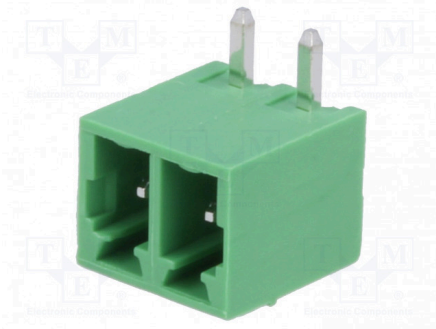

- Communications connector:

SKU: 15EDGKD-2.5-XXP-1Y-00A(H)

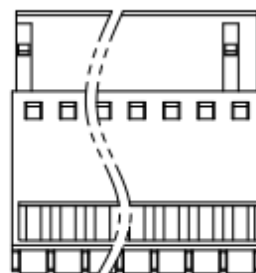
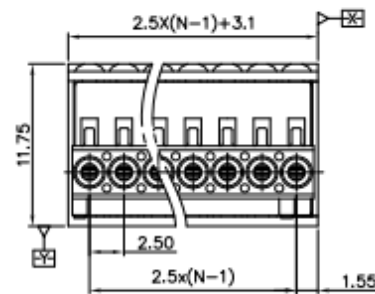
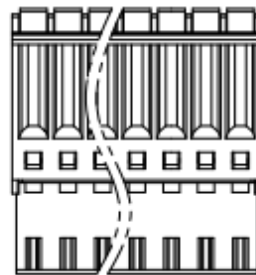

- Reset connector:

SKU: B2B-XH-A (LF)(SN)



Shape A

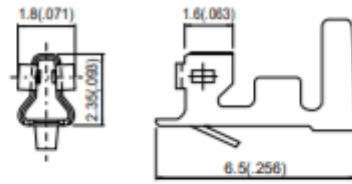

Shape B

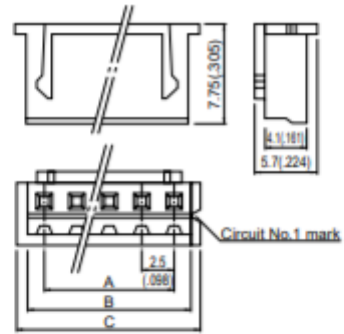
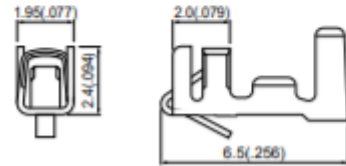

**Plugged up
(2 circuits 10.0mm(.394") pitch)**

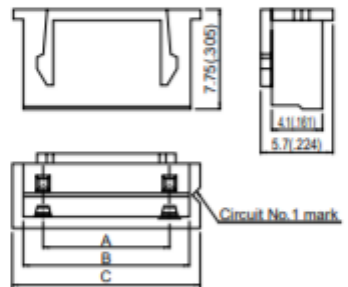

(6 circuits 5.0mm(.197") pitch)

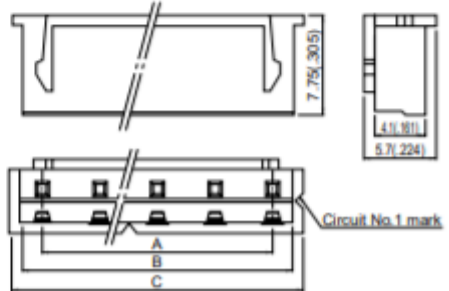

2 Raspberry Pi Connections

To start working with the UPS on your Raspberry Pi module, you need to download the `rpishutdown` file and `rpishutdown.service` provided on this [link](#).

2.1 Enable the controlled shutdown on your Raspberry Pi

The “`rpishutdown`” service allows the UPS to do a controlled shutdown of the Operative System once it detects that the main power inlet of the Raspberry PLC has been disabled. It ends all active processes before the shutdown, protecting the SD card image and all the files inside.

Once both files (“`rpishutdown`” and “`rpishutdown.service`”) have been downloaded, the next step is to move these files into the following addresses, as described in the following steps.

We are going to copy the “`rpishutdown`” file to “`/usr/local/bin/`”. This directory is usually created by default but, in case it is not, you can create this folder executing this command:

```
sudo mkdir -p /usr/local/bin
```

Once we are on the expected folder, we are going to execute these commands in the following command:

```
cd /usr/local/bin  
sudo chmod ugo+x rpishutdown
```

Now that the “`rpishutdown`” file has permissions, the next step is to copy the “`rpishutdown.service`” on the expected folder using the following command:

```
mv rpishutdown.service /lib/systemd/system
```

Finally, the service needs to be activated to run on the Operative System, this can be achieved with the next command:

```
sudo systemctl start rpishutdown.service
```

The service can be also stopped if needed:

```
sudo systemctl stop rpishutdown.service
```

2.2 Enable the RTC functionality on your Raspberry Pi

To enable the RTC functionalities, the steps to follow are:

- In order to ensure you have got the latest updates you should run the following commands:

```
sudo apt-get update
sudo apt-get -y upgrade
```

- In the file `/boot/config.txt` uncomment the following line:

```
dtoverlay=i2c_arm=on
```

- At the end of the file `/boot/config.txt`, after the “[all]” statement, introduce the following line:

```
dtoverlay=i2c-rtc,ds3231
```

Finally, the last step requires restarting the Raspberry Pi so that the changes made are saved and you can work with the RTC integrated in the UPS.

2.3 Enable the RS-485 functionality on your Raspberry Pi

The UPS Shield module contains a 2-wire RS-485 (or RS-422) transceiver. The transceiver is driven by the Raspberry Pi UART interface on the GPIO14 and GPIO15 pins. We send and receive data by `/dev/ttyS0`.

- In order to ensure you have got the latest updates you should run the following commands:

```
sudo apt-get update
sudo apt-get -y upgrade
```

- At the end of the file `/boot/config.txt`, after the “[all]” statement introduce the following line:

```
enable_uart=1
```

The following table includes the RS-485 port requirements:

Parameter	Value	Conditions
<i>RS-485 Interface Communication Type</i>	2-wire, half duplex	Transceiver chip ISL8483E
<i>RX/TX direction control</i>	Controlled by GPIO24	Diver enabled by a low TX data bit Driver disabled 25 us after the end of a low TX data bit
<i>Failsafe biasing</i>	390R to GND 390R to 5V	
<i>Line Termination</i>	120R	390R//220R//390R+2*10R
<i>Protection</i>	ESD to +/- 15 kV	No Surge/Burst protection
<i>Echo-feature</i>	RX always enabled TX enabled at data	Optional
<i>Data transmission speed</i>	0...250kbps	25 us transmission pause between TX and RX required

3 Revision table

Revision Number	Date	Changes
0	28/04/2020	First implementation
1	26/07/2023	Minor Changes
2	27/09/2024	Added section 1.3 ("Precautions")

About Industrial Shields:

Direction: Camí del Grau, 25

Zip/Postal Code: 08272

City: Sant Fruitós de Bages (Barcelona)

Country: Spain

Telephone: (+34) 938 760 191 / (+34) 635 693 611

Mail: industrialshields@industrialshields.com