

WIS Controllers

Manual

Let's connect



WIS-MKR1010-A1

WIS-MKR1010-LORA-A1

WIS-MKR1010-NBIOT-A1

WIS-ESP32-A1

WIS-ESP32-LORA-A1

WIS-ESP32-NBIOT-A1



Industrial Shields

Prerequisite:

Software:

- Arduino IDE Platform Version 1.8.15 or above
- USB Drivers for WIS-ESP32-A1 series

Hardware:

- External Power Supply unit (12/24Vdc)
- Micro USB type B to USB converter

Revision history

Version	Date	Change log	Author
00	2021-10	Draft	-
01	2022-03	Draft corrections	-
02	2022-04	Technical details upgrade	-
03	2022-06	Technical & General Specs revision + Mechanical dimension review	-
04	2024-04	CE and UKCA compliance review	-
05	2024-09	"Precautions" section added	-

Intended Audience

This User Guide is intended for the following audience:

- Persons in charge of introducing automation devices.
- Persons who design automation systems.
- Persons who install or connect automation devices.
- Persons who manage working automation installation.

Contact

Direction: Camí del Grau, n°25
Zip / Postal Code: 08272
City: Sant Fruitós de Bages (Barcelona)
Telephone: +34 938 760 191 / +34 644 927 900
Mail: industrialshields@industrialshields.com
Website: www.industrialshields.com

For further support please contact your local sales representative.

Preface

This User Guide has been implemented by Boot & Work, S.L. working under the name Industrial Shields.

Application Considerations and Warranty

Read and Understand this Manual

Please read and understand this manual before using the product. Please consult your comments or questions to Industrial Shields before using the product.

Application Consideration

THE PRODUCTS CONTAINED IN THIS DOCUMENT ARE NOT SAFETY RATED. THEY SHOULD NOT BE RELIED UPON AS A SAFETY COMPONENT OR PROTECTIVE DEVICE FOR ENSURING SAFETY OF PERSONS, AS THEY ARE NOT RATED OR DESIGNED FOR SUCH PURPOSES.

Please know and observe all prohibitions of use applicable to the products.

FOR AN APPLICATION INVOLVING SERIOUS RISK TO LIFE OR PROPERTY WITHOUT ENSURING THAT THE SYSTEM AS A WHOLE HAS BEEN DESIGNED TO ADDRESS THE RISKS, NEVER USE THE INDUSTRIAL SHIELDS PRODUCTS.

NEVER USE THE INDUSTRIAL SHIELDS PRODUCTS BEFORE THEY ARE PROPERLY RATED AND INSTALLED FOR THE INTENDED USE WITHIN THE OVERALL EQUIPMENT OR SYSTEM.

Industrial Shields shall not be responsible for conformity with any codes, regulations or standards that apply to the combination of products in the customer's application or use of the product.

The following are some examples of applications for which particular attention must be given. This is not intended to be an exhaustive list of all possible uses of the products, nor is it intended to imply that the uses may be suitable for the products:

- Systems, machines, and equipment that could present a risk to life or property.
- Nuclear energy control systems, combustion systems, railroad systems, aviation systems, medical equipment, amusement machines, vehicles, safety equipment, and installation subject to separate industry or government regulations.
- Outdoor use involves potential chemical contamination or electrical interference, or conditions or uses not described in this document.

At the customer's request, INDUSTRIAL SHIELDS will provide applicable third-party certification documents identifying ratings and limitations of use that apply to the products. This information by itself is not sufficient for a complete determination of the suitability of the products in combination with the system, machine, end product, or other application or use.

Disclaimers

Weights and Dimensions

Dimensions and weights are nominal and they are not used for manufacturing purposes, even when tolerances are shown.

Performance Data

The performance data given in this manual is provided as a guide for the user in determining suitability and does not constitute a warranty. It may represent the result of INDUSTRIAL SHIELDS's test conditions, and the users most correlate it to actual application requirements. Actual performance is subject to the INDUSTRIAL SHIELDS Warranty and Limitations of Liability.

Errors and Omissions

The information in this document has been carefully checked and is believed to be accurate; however, no responsibility is assumed for clerical, typographical, or proofreading errors, or omissions.

The control and drive components of an Industrial Shields PLC are approved for industrial and commercial use in industrial line supplies. Their use in public line supplies requires a different configuration and/or additional measures. These components may only be operated in closed housings or in higher-level control cabinets with protective covers that are closed, and when all of the protective devices are used. These components may only be handled by qualified and trained technical personnel who are knowledgeable and observe all of the safety information and instructions on the components and in the associated technical user documentation. When carrying out a risk assessment of a machine in accordance with the EU Machinery Directive, the machine manufacturer must consider the following residual risks associated with the control and drive components of a PDS.

1. Unintentional movements of driven machine components during commissioning, operation, maintenance, and repairs caused by, for example: – Hardware defects and/or software errors in the sensors, controllers, actuators, and connection technology – Response times of the controller and drive – Operating and/or ambient conditions not within the scope of the specification – Condensation / conductive contamination – Parameterization, programming, cabling, and installation errors – Use of radio devices / cellular phones in the immediate vicinity of the controller – External influences / damage.
2. Exceptional temperatures as well as emissions of noise, particles, or gas caused by, for example: – Component malfunctions – Software errors – Operating and/or ambient conditions not within the scope of the specification – External influences / damage.
3. Hazardous shock voltages caused by, for example: – Component malfunctions – Influence of electrostatic charging – Induction of voltages in moving motors – Operating and/or ambient conditions not within the scope of the specification – Condensation / conductive contamination – External influences / damage
4. Electrical, magnetic and electromagnetic fields generated in operation that can pose a risk to people with a pacemaker, implants or metal replacement joints, etc. if they are too close.

5. Release of environmental pollutants or emissions as a result of improper operation of the system and/or failure to dispose of components safely and correctly.

Warranty and Limitations of Liability

Warranty

Industrial Shields's exclusive warranty is that the products are free from defects in materials and workmanship for a period of one year (or other period if specified) from date of sale by Industrial Shields.

INDUSTRIAL SHIELDS MAKES NO REPRESENTATION OR WARRANTY, EXPRESSED OR IMPLIED, REGARDING MERCHANTABILITY, NON-INFRINGEMENT, OR FITNESS FOR PARTICULAR PURPOSE OF THE PRODUCTS. ANY BUYER OR USER ACKNOWLEDGES THAT THE BUYER OR USER ALONE HAS DETERMINED THAT THE PRODUCTS WILL SUITABLY MEET THE REQUIREMENTS OF THEIR INTENDED USE. INDUSTRIAL SHIELDS DISCLAIMS ALL OTHER WARRANTIES, EXPRESS OR IMPLIED

Limitations of Liability

INDUSTRIAL SHIELDS SHALL NOT BE RESPONSIBLE FOR SPECIAL, INDIRECT, OR CONSEQUENTIAL DAMAGES, LOSS OF PROFITS OR COMERCIAL LOSS IN ANY WAY CONNECTED WITH THE PRODUCTS, WHETHER SUCH CLAIM IS BASED ON CONTRACT, WARRANTY, NEGLIGENCE, OR STRICT LIABILITY.

IN NO EVENT SHALL INDUSTRIAL SHIELDS BE RESPONSIBLE FOR WARRANTY, REPAIR OR OTHER CLAIMS REGARDING THE PRODUCTS UNLESS INDUSTRIAL SHIELDS'S ANALYSIS CONFIRMS THAT THE PRODUCTS WERE PROPERLY HANDLED, STORED, INSTALLED, AND MAINTAINED AND NOT SUBJECT TO CONTAMINATION, ABUSE, MISUSE, OR INAPPROPRIATE MODIFICATION OR REPAIR.

Table of Contents

1 About this documentation	9
1.1 Symbols and notes	9
2 Safety	12
2.1 General Safety Notice	12
2.2 Precautions	13
2.2.1 Raspberry Board	13
2.2.2 Intended Audience	13
2.2.3 General Precautions	13
2.2.4 Isolation Precautions	13
3 System Overview	14
3.1 General specifications	14
3.2 Mechanical Dimensions	15
3.3 Connectors	16
3.4 Device Overview	17
3.5 WIS MKR1010	18
3.5.1 CPU Specifications	18
3.5.2 Pin-Out of WIS MKR1010 series	19
3.6 WIS ESP32	20
3.6.1 CPU Specifications	21
3.6.2 Software Requirements	21
3.6.3 Pin-Out of WIS ESP32 series	21
3.7 Power Supply	23
3.8 Ferrite TRM-16-8-16E-WE – How to connect	24
3.9 Reset Button	26
3.10 Switch Configuration	26
3.11 IO's Configuration	27
3.11.1 Digital Inputs	27
3.11.2 Digital Outputs	28
3.11.3 Analogue / Digital Inputs Configurable	29
3.11.4 Analogue Output	31
3.11.5 Multi-Function Pins	32
3.12 Available communications	34
3.12.1 Serial TTL (UART)	34
3.12.2 RS-485	35
3.12.3 Ethernet	36
3.12.4 WiFi	37
3.12.5 Bluetooth Low Energy	37
3.12.6 SPI	38

3.12.6.1 Internal SPI Block Diagram for WIS PLC Series.....	38
3.12.7 I2C.....	39
3.12.7.1 Internal I2C Block Diagram for WIS MKR1010 Series.....	40
3.12.7.2 Internal I2C Block Diagram for WIS ESP32 Series.....	40
3.13 Other functionalities.....	41
3.13.1 RTC.....	41
3.13.2 EEPROM.....	41
3.13.3 ATECC Encryption Chipset.....	42
3.13.4 uSD slot.....	42
3.14 Additional Communications.....	43
3.14.1 LoRa and LoRaWAN.....	43
3.14.2 NB IoT.....	44
3.14.3 Antennas.....	44
3.14.3.1 WiFi Antennas.....	45
3.14.3.2 LoRa Antennas.....	47
3.14.3.3 Cellular Antennas.....	49
4 Software Programming.....	52
4.1 Connect WIS to PC.....	52
4.2 Arduino IDE.....	53
5 Installation & Maintenance.....	56

1 About this documentation

1.1 Symbols and notes

The safety notices in this documentation are designed according to the severity of the danger.

	DANGER
	Imminent risk to life! Notes with the signal word “Danger” warn you of situations which will result in serious injury or death if you do not follow the instructions given in this manual.









	WARNING
	Possible danger to life! Notes with the signal word “Warning” warn you of situations which may result in serious injury or death if you do not follow the instructions given in this manual.

	CAUTION
	Risk of injury! Notes with the signal word “Caution” warn you of situations which may result in injury if you do not follow the instructions given in this manual.

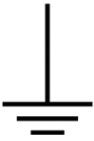
ATTENTION
Material damage! Notes with the signal word “Attention” warn you of hazards which may result in material damage.

Text next to this arrow are notes which are not relevant to safety but provide important information about proper and effective work procedures.

Table that includes all the symbology that is used in the serigraph of the WIS Family products:

Symbol	Standard No. / Standard Title	Standard Reference No. / Symbol Title	Symbol Meaning
	IEC 60417 / Graphical symbols for use on equipment	5031 / Direct Current	Indicates that the equipment is suitable for direct current only; to identify relevant terminals
	IEC 60417 / Graphical symbols for use on equipment	5130 / Pulse General	To identify the control by which a pulse is started.
	IEC 60417 / Graphical symbols for use on equipment	5017 / Earth, Ground	To identify an earth (ground) terminal in cases where neither the symbol 5018 nor 5019 is explicitly required.
	IEC 60417 / Graphical symbols for use on equipment	5115 / Signal lamp	To identify the switch by means of which the signal lamp(s) is (are) switched on or off.
	2014/30/UE / Electromagnetic Compatibility	CE Marking	CE marking indicates that a product complies with applicable European Union regulations
	2016_1091 / Electromagnetic Compatibility	UKCA Marking	UKCA marking indicates that a product complies with applicable United Kingdom regulations
	ISO 7000/ Graphical symbols for use on equipment	0434B / Warning symbol	Indicates a potentially hazardous situation which, if not avoided, could result in death or serious injury
	ISO 7000/ Graphical symbols for use on equipment	5036 / Dangerous Voltage	To indicate hazards arising from dangerous voltages

- Unused pins should not be connected. Ignoring the directive may damage the controller.
- Improper use of this product may severely damage the controller.
- Refer to the controller's User Guide regarding wiring considerations.
- Before using this product, it is the responsibility of the user to read the product's User Guide and all accompanying documentation.
- Maintenance must be performed by qualified personnel familiarized with the construction, operation, and hazards involved with the control.

- Maintenance should be performed with the control out of operation and disconnected from all sources of power.
- Care should be taken when servicing electrostatic sensitive components. The manufacturer's recommendations for these components should be followed.
- The WIS PLC Family products are Open Type Controllers. It is required that you install the WIS PLC in a housing, cabinet, or electric control room. Entry to the housing, cabinet, or electric control room should be limited to authorized personnel. Failure to follow these installation requirements could result in severe personal injury and/or property damage. Always follow these requirements when installing WIS family PLCs.
- In case of installation or maintenance of the WIS PLC Family products please follow the instructions marked in the Installation and Maintenance section.
- Do not disconnect equipment when a flammable or combustible atmosphere is present. Disconnection of equipment when a flammable or combustible atmosphere is present may cause a fire or explosion which could result in death, serious injury and/or property damage.

2 Safety

This section includes general safety instructions for handling the WIS family products. Specific warning notices for specific tasks and situations are given at the appropriate places in the documentation. Failure to observe the safety and warning notices can result in damage to persons and material.

2.1 General Safety Notice

Consider the following steps to follow. A false manoeuvre could be the cause of an accident or material damage.

Do not disassemble or modify the modules. This could lead to breakdowns or malfunctions and could lead to injuries or fire.

- All types of radio communication devices, including mobile phones and personal handy-phone systems (PHS), must be kept more than **25cm** away from the PLC in all directions. Failure to observe this precaution exposes malfunctions caused by excess temperature.
- Disconnect the external power supply of the system (on all phases) before connecting or disconnecting a module. Failure to observe this precaution may cause faults or malfunctions of the module.
- Tighten the screws of the terminal ports and the screws of the connectors within the prescribed tightening torque. Insufficient tightening can lead to loose parts or wires and cause malfunctions. Excessive tightening can damage the screws and / or the module, with the risk of falling, short circuits, and malfunctions.
- Before handling a module, dispose of the electrostatic charge accumulated by the human body by touching a suitable conductive object. Failure to observe this precaution may cause faults or malfunctions of the module.

Fuse protection

The operator must set up the equipment so that it is protected against overloading. The 12V DC or 24 V DC power supply units used must fulfill the SELV category, no matter whether they supply the system or feed-in modules. The output voltage of the feed-in power supply has to fulfill overvoltage category 1 according to IEC 61010. When connecting to outer current circuits the respective overload category must be regarded for each single module of the u-control station (see technical data).

The main switch, the switches of the subsequent circuits, the cable cross sections and the fuse protection must be configured according to IEC 61010.

Earthing

Via an FE spring on its underside each controller and each module is electrically connected to the DIN rail. This connection is only established if the assembly is carried out carefully and in accordance with the instructions. To ensure the earthing of the station the DIN rail must be connected to the protective earth via the earth terminals (PE).

Several modules have connections with green pushers. An FE potential is also provided at these connections. **They must not be used as a PE!**

Electromagnetic Compatibility RED Directive

The IEC 61000 standard on immunity requirements for electromagnetic compatibility applies to standard and additional wireless communications in the WIS family of PLCs.

The immunity requirements have been selected to ensure an adequate level of immunity for devices used in industrial settings. The equipment meets the essential electromagnetic compatibility requirements concerning immunity.

According to the regulations that are part of EN 61131-2: 2007 and specifically, the sections

61000-6-2 for immunity and 61000-6-3 for emissions, WIS models ensure the smooth operation of all your wireless networks in industrial and / or domestic environments.

2.2 Precautions

Read this manual before attempting to use the WIS CONTROLLER and follow its descriptions for reference during operation.

2.2.1 Raspberry Board

The WIS CONTROLLER includes a Raspberry Pi 4 Board as controller.

2.2.2 Intended Audience

This manual is intended for technicians, which must have knowledge on electrical systems.

2.2.3 General Precautions

The user must operate the WIS Controller according to the performance specifications described in this manual.

Before using the WIS CONTROLLER under different conditions from what has been specified in this manual or integrating into nuclear control systems, railroad systems, aviation systems, vehicles, combustion systems, medical equipment, amusement machines, safety equipment and other systems, machines, and equipment that may have a serious influence on lives and property if used improperly, consult your INDUSTRIAL SHIELDS representative. Ensure that the rating and performance characteristics of the WIS Controller are sufficient for the systems, machines, and equipment, and be sure to provide the systems, machines, and equipment double safety mechanisms. This manual provides information for programming and operating the WIS Controller,

2.2.4 Isolation Precautions

Description:

This equipment does **not include galvanic isolation between the grounds** of the different systems. This means that if an external device or sensor that shares the same ground reference (GND) with the system is connected, any potential difference between these grounds could damage the connected components. To avoid issues with interference, ground loops, or damage to external equipment, ensure that all connected devices share the same ground reference or use systems with appropriate isolation.

Recommendations:

- **Connection Review:** Verify that all ground connections are properly made and that there are no significant potential differences between them.
- **Use of Isolation:** Consider using galvanic isolators or isolation transformers if it is necessary to connect equipment with different ground references.

3 System Overview

Within the WIS PLC family, there are two main variants in terms of CPUs. These variants integrate the MKR1010 CPU and the ESP32 CPU, below are the main characteristics of each of the CPUs and the functionalities and general specifications of the WIS PLC family.

3.1 General specifications

WIS PLC FAMILY GENERAL SPECIFICATIONS		
Input Voltage	12 to 24Vdc ===	
Input rated voltage	11.4 to 25.4 Vdc ===	
Rated Power	30 W	
I max. at 24Vdc	1.5A	
Ambient Temperature (Operating)	0° to 60°C	
Ambient Temperature (Storage)	-20° to 60°C	
Ambient Humidity (Operating)	10% to 90% (Without Condensation)	
Ambient Environment (Operating)	With no corrosive gas	
Max. Operating Altitude	2000m (6562 ft)	Will work without derating at a maximum altitude of 2000m
Pollution Degree	PD2	Normally only non conductive pollution occurs. Temporary conductivity caused by condensation is to be expected.
Size	107x46x127	
Communications	Ethernet – RS485 and Serial TTL (Selectable by switch) SPI – Wi-Fi (With external Antenna) – Bluetooth Low Energy – I2C	
USB consideration!	Only meant for uploading or debugging, not always connected as a serial in a project!	Cannot be working in a final application
Analog Input 12bit (0-10VDC)	0 to 10Vdc Input Impedance: 39K Separated PCB ground Rated Voltage: 10Vac ===	I max: 2mA at 10Vdc
Digital Isolated Input (5-24VDC)	5 to 24Vdc I max: 12 mA Galvanic Isolation Rated Voltage: 24 Vdc ===	I max: 12 mA at 24Vdc

<p>Analog Output 10 bit (0-10VDC)</p>	<p>0 to 10Vdc I max: 10 mA Separated PCB ground Rated Voltage: 10VDC</p> <p>==</p>	<p>I max: 10 mA at 10Vdc</p>
<p>Digital Isolated Output (24VDC*)</p>	<p>5 to 24VDC I max: 70 mA Galvanic Isolation Diode Protected for Relay Rated Voltage: 24VDC</p> <p>==</p>	<p>I_{max} at 24Vdc: 410 mA (total amount of all Digital Isolated Outputs)</p>
<p>Multi-Function pins (3.3VDC/5VDC)</p>	<p>0 to 3,3 or 0 to 5 VDC *Voltage range configurable by switch Can be used as Digital or Analogue Can be used as CS on SPI Communication</p> <p>==</p>	
<p>Expandability</p>	<p>(I2C - 127 elements) - Serial Port and RS485 (Up to 32 devices with Modbus RTU)</p>	
<p>* By using this type of signal can no longer use Digital signal (24Vdc)</p>		

3.2 Mechanical Dimensions

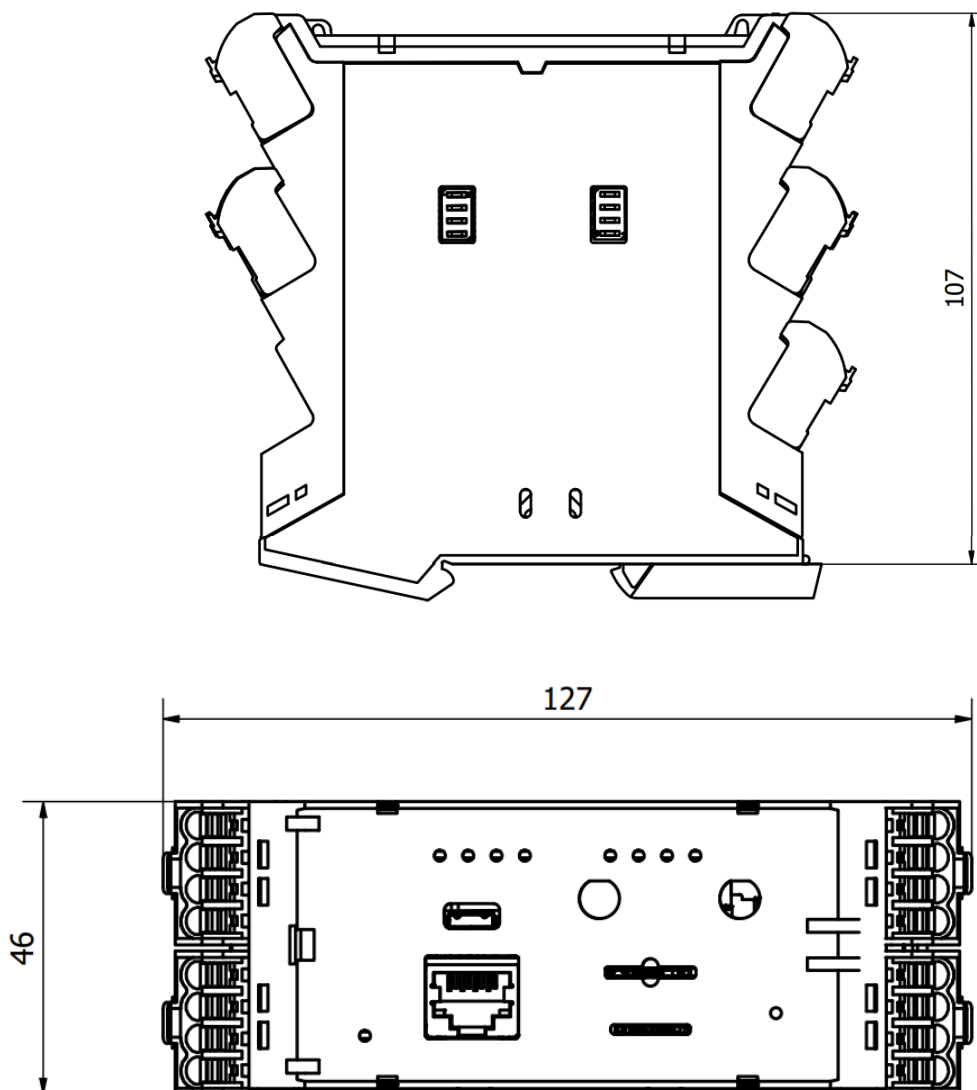

3.3 Connectors

On the WIS PLC series, conductors can be connected to each connector. “PUSH IN” technology allows for fine-wired conductors with crimped wire-end ferrules or ultrasonically welded conductors, each with a maximum cross-section of 1.5 mm², to be inserted easily through the opening in the clamping terminal without having to use tools. To insert fine-wired conductors without wire-end ferrules, the pusher must be pressed in with a screwdriver.

Connector’s type and references:

		
Ref. 1497500000 – (0-10Vdc / 24 Vdc) Signals	Ref. 1989090000 – TTL 5Vdc Signal	Ref. 1989190000 – RS-485 Communication port

Connectors General Specifications:

Connectors PG	1.5 mm with four conductor connections
Max. Ampacity	10 A
Poles	4-pole
Pushers (Color-coded as follows)	WHITE: DC or AC Signal
	BLUE: GND
	RED: 24 Vdc
	Green: Functional Earth FE
	BLACK: AC Signal only

3.4 Device Overview

Right view:



Left view:

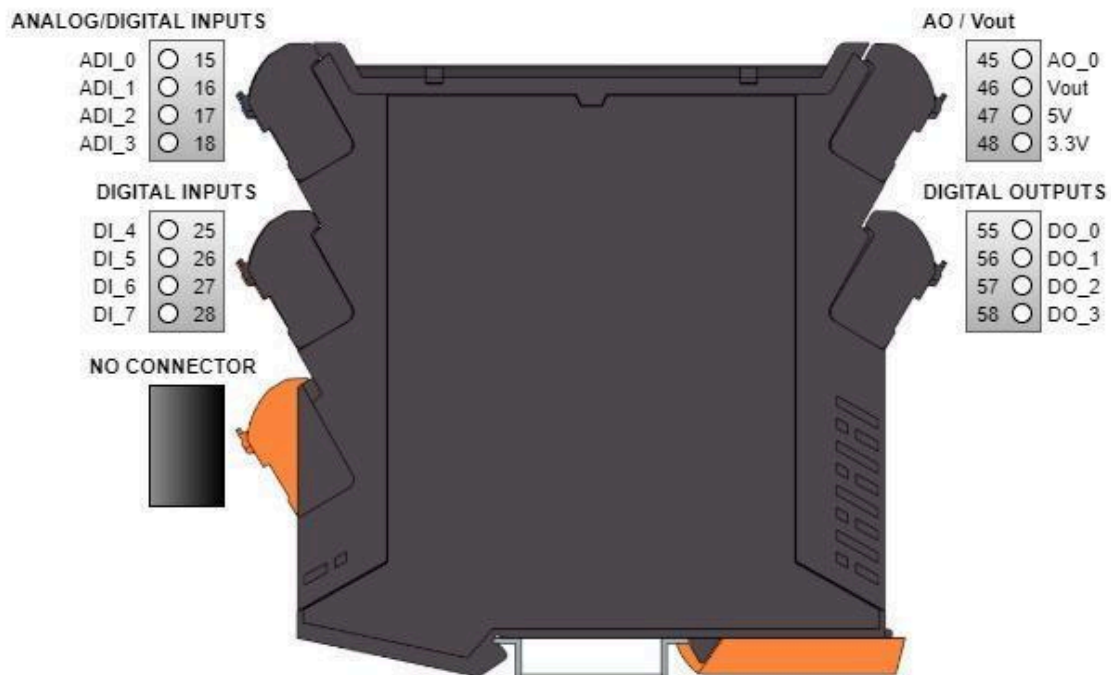

Top view:

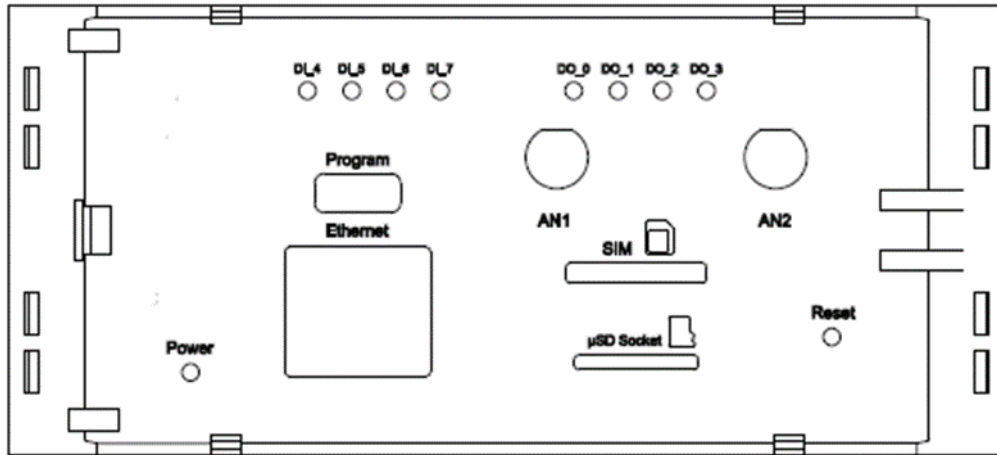

3.5 WIS MKR1010

This section specifies the characteristics of the CPU included in the WIS MKR1010 models, which are:

- WIS-MKR1010-A1
- WIS-MKR1010-LORA-A1
- WIS-MKR1010-NBIOT-A1

3.5.1 CPU Specifications

Microprocessor	SAMD21 Cortex®-M0+ 32bit low power ARM MCU (datasheet)
ROM	256 KB (internal)
SRAM	32 KB
Internal RTC Speed	32.768 kHz
QSPI supports multiple flash/SRAM chips	

3.5.2 Pin-Out of WIS MKR1010 series

SERIAL / RS-485 CONNECTORS	
WIS MKR1010 PLC Pin	Internal connection
11: A / Tx	D14 (*Configurable by switch – See chapter 3.10)
12: B / Rx	D13 (*Configurable by switch – See chapter 3.10)
13: GND	Internal GND
14: NC / RE-DE	D5 (*Configurable by switch – See chapter 3.10)
ANALOG INPUTS	
WIS MKR1010 PLC Pin	Internal connection
15: ADI_0	A2
16: ADI_1	A1
17: ADI_2	A5
18: ADI_3	A6

SUPPLY & GND OUT	
WIS MKR1010 PLC Pin	Internal connection
21: Vin+	Internal Power feed Vin+
22: Vin-	Internal Vin-
23: GND	Internal GND
24: GND	Internal GND

DIGITAL INPUTS	
WIS MKR1010 PLC Pin	Internal connection
25: DI_4	AREF
26: DI_5	D1
27: DI_6	D2
28: DI_7	D3

MULTI FUNCTION PINS	
WIS MKR1010 PLC Pin	Internal connection
41: MF0	A4 (*Configurable by switch – See chapter 3.10)
42: MF1	D0 (*Configurable by switch – See chapter 3.10)
43: 5V/3.3V	Internal Power Feed 5/3.3Vdc (*Configurable by switch – See chapter 3.10)
44: GND	Internal GND

ANALOG OUTPUT	
WIS MKR1010 PLC Pin	Internal connection
45: AO_0	A0
46: Vout	Vin (12/24Vdc) – depending on the PLC power
47: 5V	Internal Power Feed 5Vdc
48: 3.3V	Internal Power Feed 3.3Vdc

SPI	
WIS MKR1010 PLC Pin	Internal connection
51: MISO	D10
52: MOSI	D8
53: SCK	D9
54: Chip Select	D4
DIGITAL OUTPUTS	
WIS MKR1010 PLC Pin	Internal connection
55: DO_0	I2C chip MCP23008 – Add. 0x21 – GP0
56: DO_1	I2C chip MCP23008 – Add. 0x21 – GP1
57: DO_2	I2C chip MCP23008 – Add. 0x21 – GP2
58: DO_3	I2C chip MCP23008 – Add. 0x21 – GP3

I2C	
WIS MKR1010 PLC Pin	Internal connection
61: SDA	D11
62: SCL	D12
63: 3.3V	Internal Power Feed 3.3Vdc
64: GND	Internal GND

ETHERNET W5500	
WIS MKR1010 PLC Pin	Internal connection
SPI	(MISO/MOSI/SCK)
IRQ	D6
CS	I2C chip MCP23008 (0x21 – GP7)

SD CARD	
SD Card reader	Internal connection
Chip Select SD	A3
SPI	(MISO/MOSI/SCK)

RTC	
RTC DS3231	Internal connection
I2C	(SDA/SCL/CLK)

3.6 WIS ESP32

This section specifies the characteristics of the CPU included in the WIS ESP32 models, which are:

WIS-ESP32-A1

WIS-ESP32-LORA-A1

WIS-ESP32-NBIOT-A1

3.6.1 CPU Specifications

Microprocessor	Xtensa® single-/dual-core 32-bit LX6 microprocessor(s), up to 600 MIPS (200 MIPS for ESP32-S0WD/ESP32-U4WDH)
ROM	448 KB (internal)
SRAM	520 KB SRAM
Internal RTC Speed	31.25 kHz clock
QSPI supports multiple flash/SRAM chips	

3.6.2 Software Requirements

If using any of the WIS ESP32 PLC models, you will need to install the following packages on your computer (MAC OSX / Windows/ Linux).

- [USB Drivers](#)
- [Virtual COM Port Drivers](#)

3.6.3 Pin-Out of WIS ESP32 series

SERIAL / RS-485 CONNECTORS	
WIS ESP32 PLC Pin	Internal connection
11: A / Tx	IO17 (*Configurable by switch – See chapter 3.10)
12: B / Rx	IO16 (*Configurable by switch – See chapter 3.10)
13: GND	Internal GND
14: NC / RE-DE	IO33 (*Configurable by switch – See chapter 3.10)

ANALOGUE/DIGITAL INPUTS	
WIS ESP32 PLC Pin	Internal connection
15: ADI_0	ADS1015 - AI1 (0x49)
16: ADI_1	ADS1015 – AI0 (0x49)
17: ADI_2	ADS1015 – AI2 (0x49)
18: ADI_3	ADS1015 – AI3 (0x49)

SUPPLY & GND OUT	
WIS ESP32 PLC Pin	Internal connection
21: Vin+	Internal Power feed Vin+
22: Vin-	Internal Vin-
23: GND	Internal GND
24: GND	Internal GND

DIGITAL INPUTS	
WIS ESP32 PLC Pin	Internal connection
25: DI_4	IO35
26: DI_5	IO2 (*)
27: DI_6	IO15
28: DI_7	IO5

MULTI FUNCTION INPUTS	
WIS ESP32 PLC Pin	Internal connection
41: MF0	IO27 (*Configurable by switch – See chapter 3.10)
42: MF1	IO4 (*Configurable by switch – See chapter 3.10)
43: 5V/3.3V	Internal Power Feed 5/3.3Vdc (*Configurable by switch – See chapter 3.10)
44: GND	Internal GND

ANALOG OUTPUT	
WIS ESP32 PLC Pin	Internal connection
45: AO_0	IO26
46: Vout	Vin+
47: 5V	Internal Power Feed 5Vdc
48: 3.3V	Internal Power Feed 3.3Vdc

SPI	
WIS ESP32 PLC Pin	Internal connection
51: MISO	IO19
52: MOSI	IO23
53: SCK	IO18
54: CS	IO25

DIGITAL OUTPUTS	
WIS ESP32 PLC Pin	Internal connection
55: DO_0	I2C chip MCP23008 – Add. 0x21 – GP0
56: DO_1	I2C chip MCP23008 – Add. 0x21 – GP1
57: DO_2	I2C chip MCP23008 – Add. 0x21 – GP2
58: DO_3	I2C chip MCP23008 – Add. 0x21 – GP3

I2C	
WIS ESP32 PLC Pin	Internal connection
61: SDA	IO21
62: SCL	IO22
63: 3.3V	Internal Power Feed 3.3Vdc
64: GND	Internal GND

ETHERNET W5500	
W5500 Ethernet Port	Internal connection
SPI	(MISO/MOSI/SCK)
IRQ	IO32
CS	I2C chip MCP23008 (0x21 – GP7)

SD CARD	
SD Card reader	Internal connection
CS SD	IO13
SPI	(MISO/MOSI/SCK)

RTC	
RTC DS3231	Internal connection
I2C	(SDA/SCL/CLK)

3.7 Power Supply

WIS PLC Family Products can be powered from 12VDC to 24VDC requiring a minimum of 0,8A to achieve a good performance.

IMPORTANT: Polarity is NOT REVERSAL, make sure that GND and Voltage wiring are properly connected. Make sure that the power supply mains output is not higher than 24VDC.

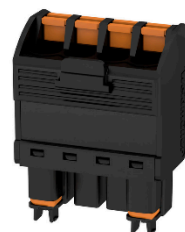
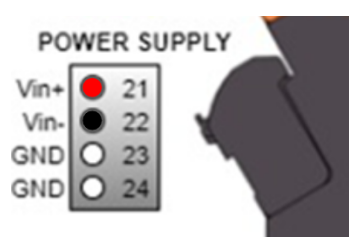

The standard, Part 1 of IEC 61010, sets the general safety requirements for the following types of electrical devices and their accessories, regardless of where use of the device is intended.

The equipment must be powered from an external power source in accordance with IEC 61010-1, whose output is MBTS and is limited in power according to section 9.4 of IEC 61010-1.

 **Warning:**

Once the equipment is installed inside an electrical cabinet, the MTBS cables of the equipment must be separated from the dangerous voltage cables.

3.8 Ferrite TRM-16-8-16E-WE – How to connect

This PLC family unit includes a TRM-16-8-16E-WE Epoxy coated ferrite core, to act as a frequency high impedance noise filter in hazardous environments.

Coated ferrite core has rounded corners to reduce load on the cable and is made of Mn-Zn soft, epoxy coated.

The use of this ferrite for industrial uses is mandatory and necessary.



Fig 3.8.1. Ferrite model TRM-16-8-16E-WE

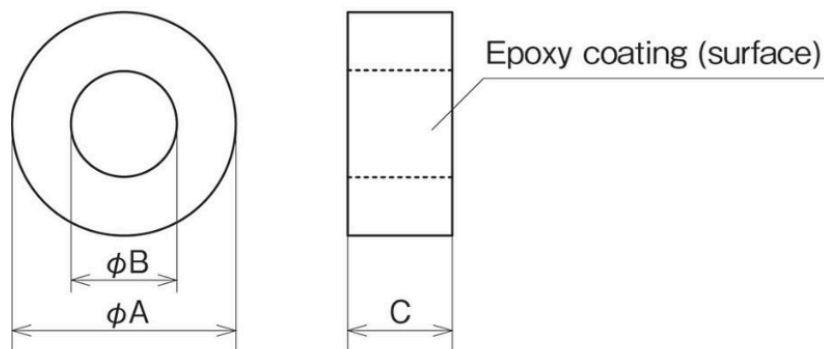

Fig 3.8.2. Ferrite model TRM-16-8-16E-WE measures legend

Ferrite Model	A	B	C	Impedance* Ω/10MHz (2 turn)
TRM-16-8-16E-WE	17.0	7.1	16.9	≥ 70

The mounting method of the ferrite included in the kit is as follows:

- In the wiring dedicated to the PLC power supply, the ferrite must be placed making 3 turns using the **negative pole** about **25 cm** from the PLC connector.
- The turns must be made to the ferrite following the instructions in the following image:



Impedance vs Frequency table depending on number of turns around the ferrite (blue: 1 turn, yellow: 2 turns, red: 3 turns):

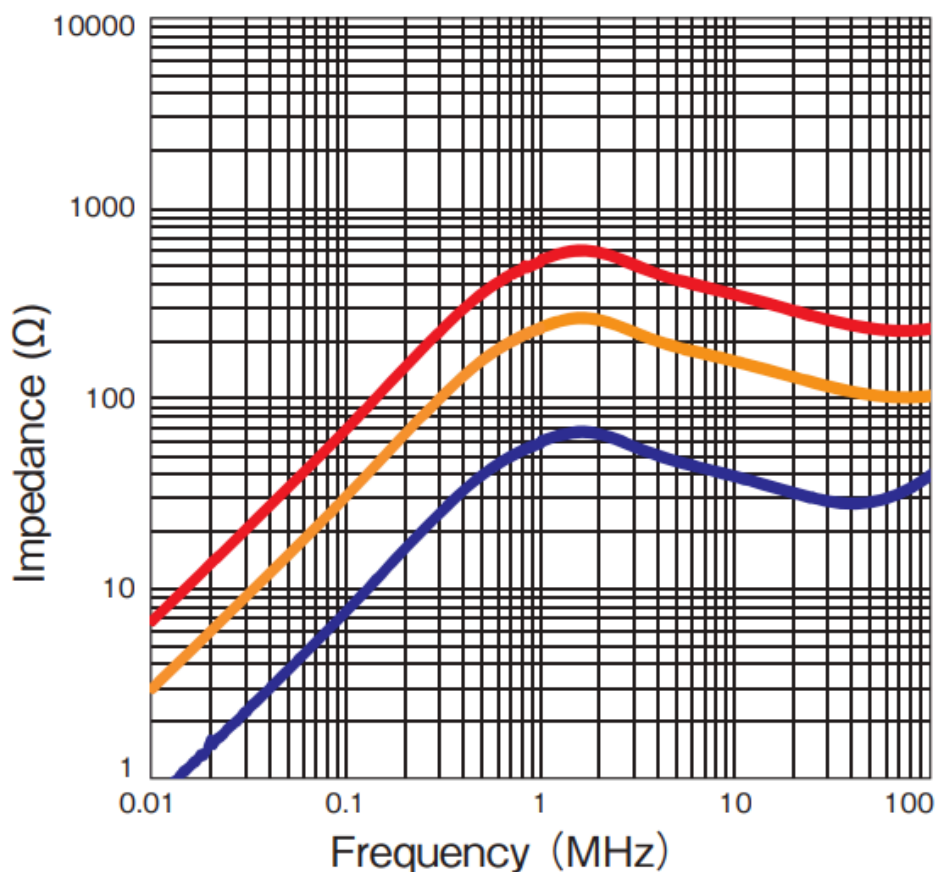

3.9 Reset Button

Located at the top cover of the WIS PLC Family products.

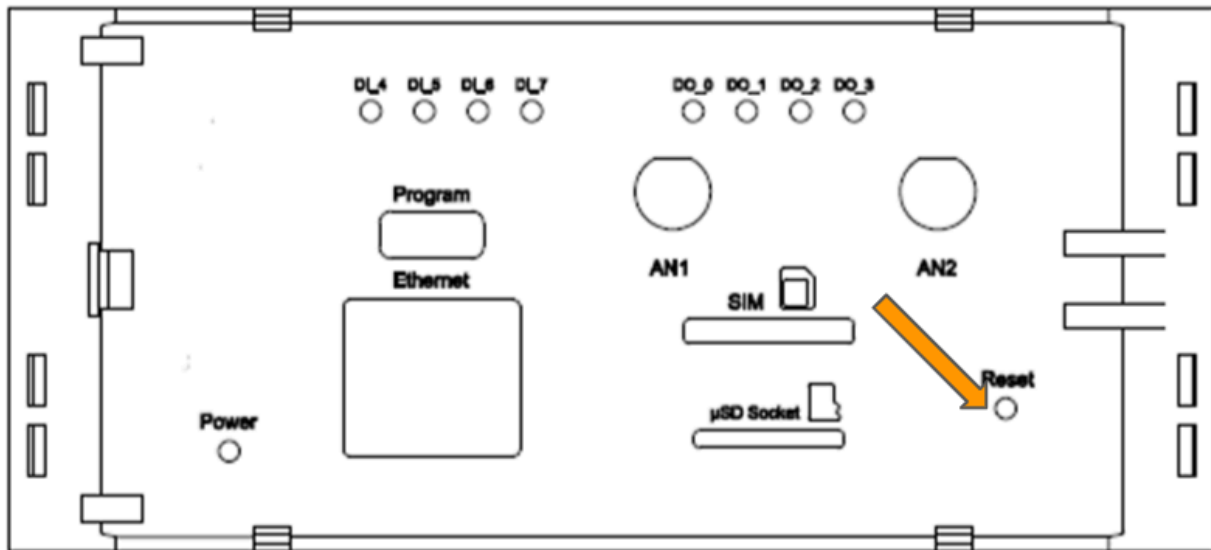

Press the reset button between 2 and 5 seconds for a correct operation.

It allows the internal logic to restart the program, to execute the set up again and to start the main loop of the program again. The data that is stored on the microSD card will be maintained without losing any information already stored, while the operations that have been left in the middle of execution will start again from the beginning of the program, losing the temporary values.

3.10 Switch Configuration

The WIS PLC Family products have two switch zones, which are located in the middle of the front part of the PLC, silk-screened as SW1 and SW2.

These switches have two main functionalities, configure pins 11 and 12 as Serial TTL or as RS-485 communication pins.

If RS485 is needed on pins 11 and 12, please check the first configuration on the diagram that you can find below.

If Serial TTL at 3.3Vdc is needed on pins 11 and 12, please check the second configuration on the diagram that you can find below.

If Multi-Function pins are needed to operate at 0-5 Vdc, please check the third configuration on the diagram below.

If Multi-Function pins are needed to operate at 0-3.3Vdc, please check the third configuration on the diagram below.

Below you can find the configuration table for SW1 and SW2:

	SW1				SW2			
	1	2	3	4	1	2	3	4
RS485	x	x	x	on	off	off	on	on
UART 3.3v TTL	x	x	x	off	on	on	off	off
0 - 5v MF	on	on	on	x	x	x	x	x
0 - 3.3v MF	off	off	off	x	x	x	x	x

3.11 IO's Configuration

3.11.1 Digital Inputs

Digital Input pins are located on the following connectors:

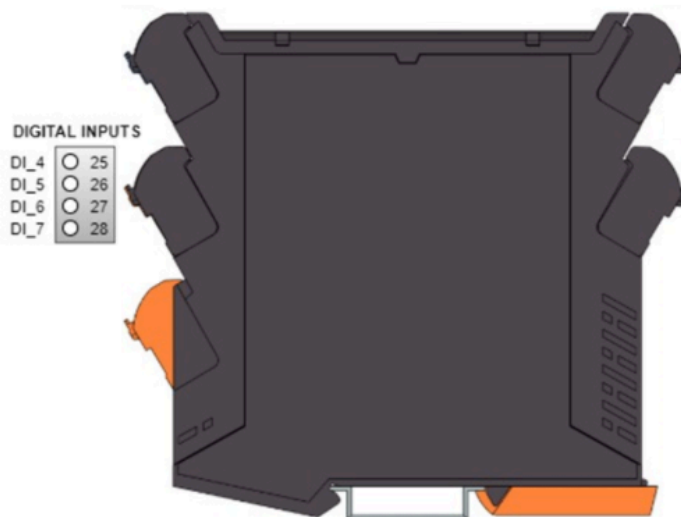

DIGITAL INPUTS
25: DI_4
26: DI_5
27: DI_6
28: DI_7

- Typical Connection:

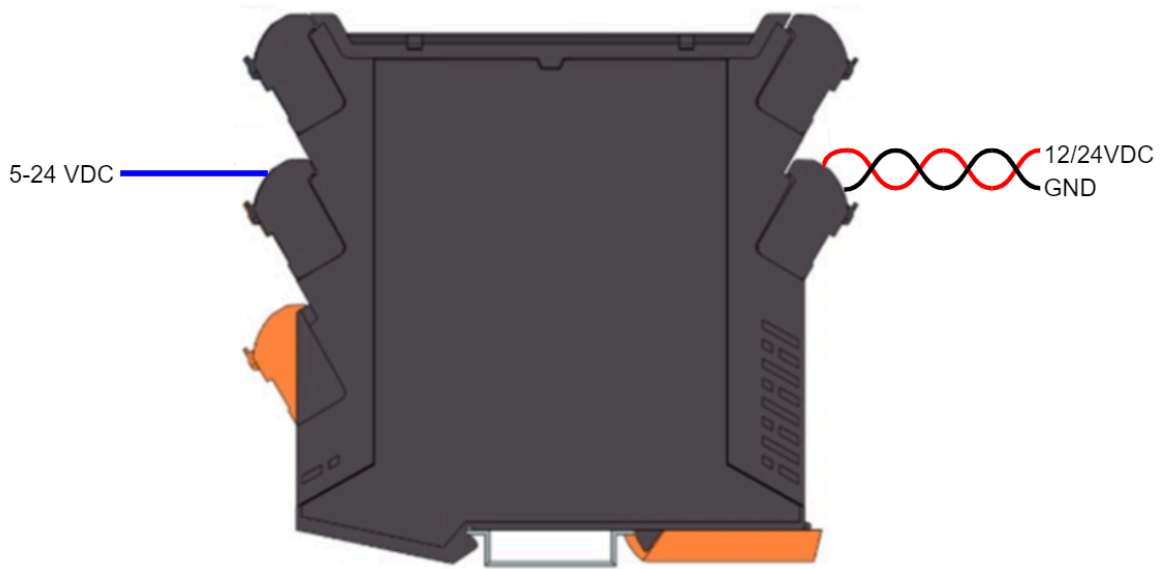

3.11.2 Digital Outputs

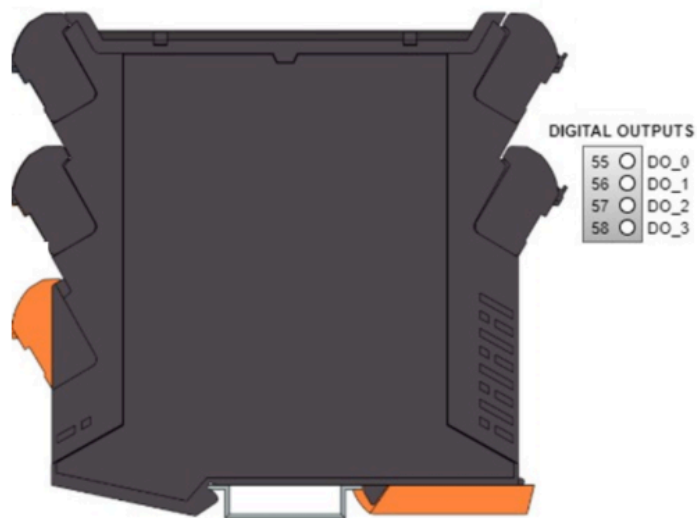

DIGITAL OUTPUTS	
55:	DO_0
56:	DO_1
57:	DO_2
58:	DO_3

- Typical Connection:

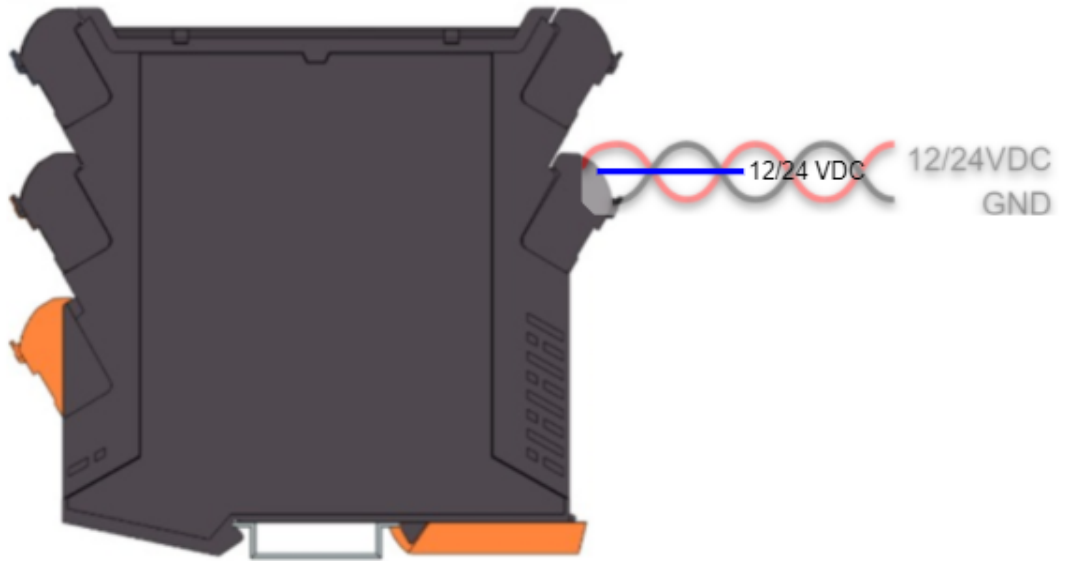

3.11.3 Analogue / Digital Inputs Configurable

ANALOG/DIGITAL INPUTS

- ADL_0 ○ 15
- ADI_1 ○ 16
- ADL_2 ○ 17
- ADI_3 ○ 18



ANALOGUE / DIGITAL INPUTS
15:ADI_0
56: ADI_1
57: ADI_2
58: ADI_3

The configuration of these inputs is selected by software and does not depend on any external switch or any additional hardware configuration.

- Typical Connections:

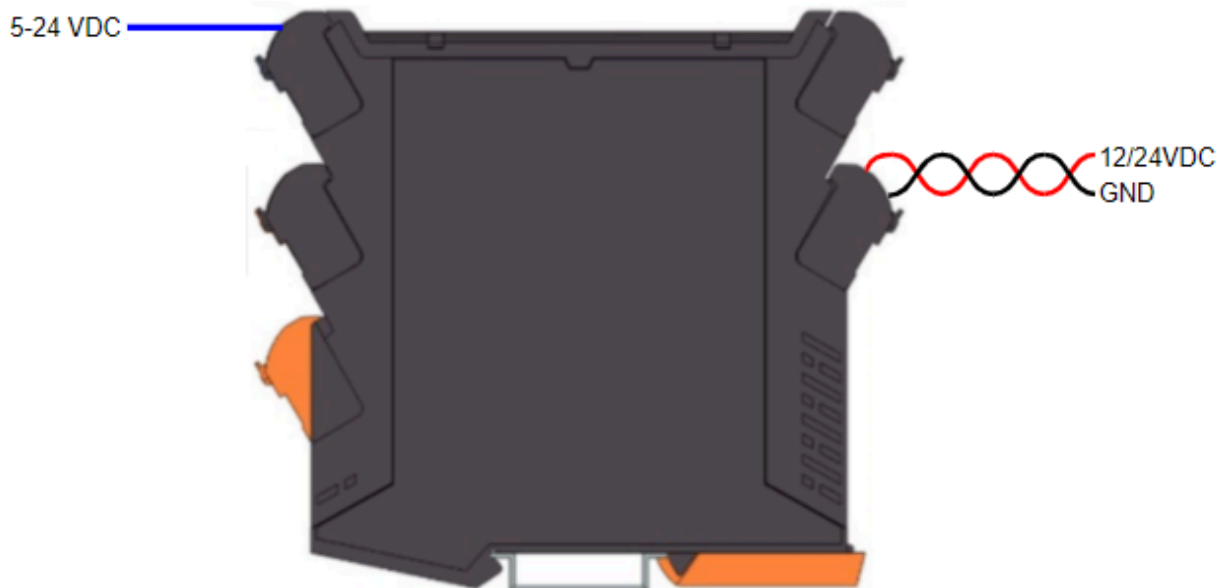

As Digital Inputs, this pins will detect HIGH state between 5 and 24Vdc, in the same way as in the opto-isolated digital inputs (see section 3.10.1)

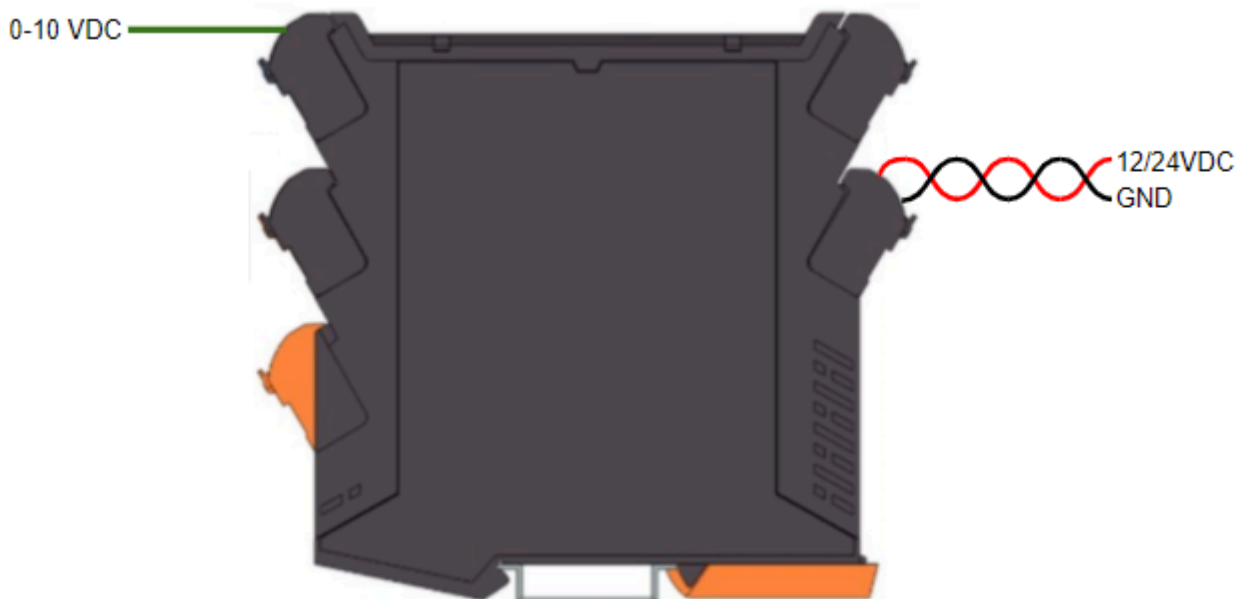

As Analog Inputs, these pins will detect the analog signal between 0 and 10Vdc with a resolution of 12 bits.

3.11.4 Analogue Output

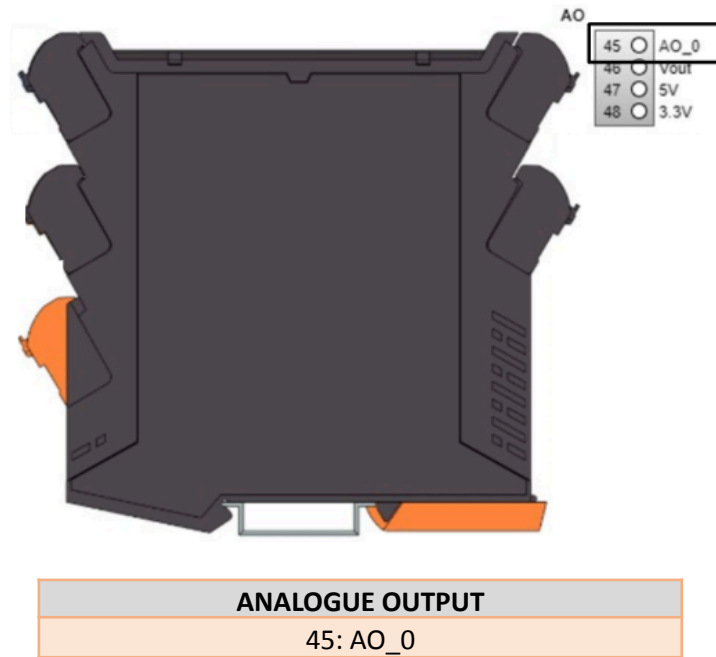

- Typical Connection:

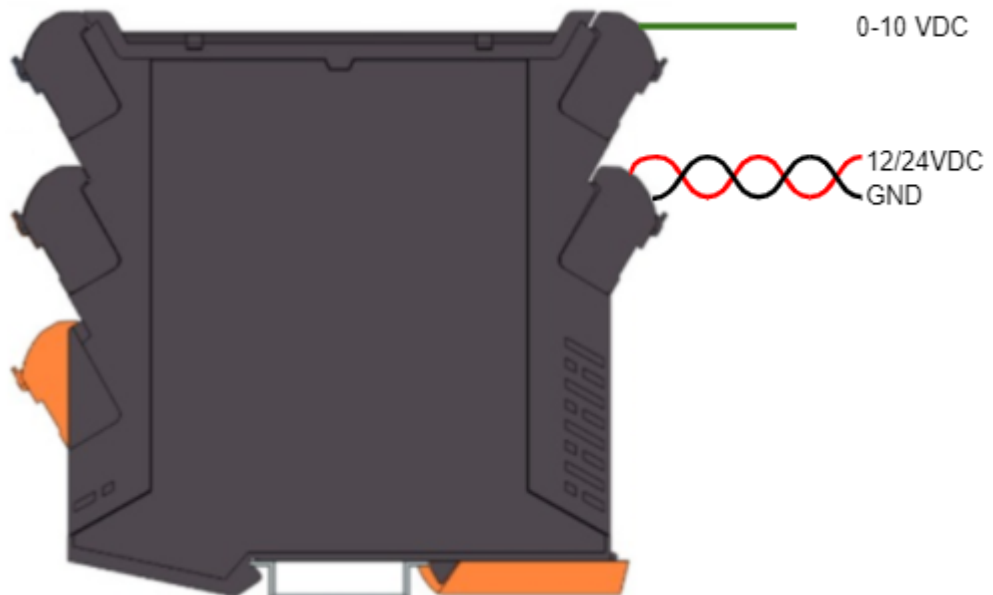

3.11.5 Multi-Function Pins

The multi-function pins allow different operations and functionality to cover different applications. MF pins can only operate at 3.3Vdc or 5Vdc (configurable by switch). It is very important to check the configuration of the switches for the use of the multi-function pins before making the connection to verify the voltage in which they are configured.

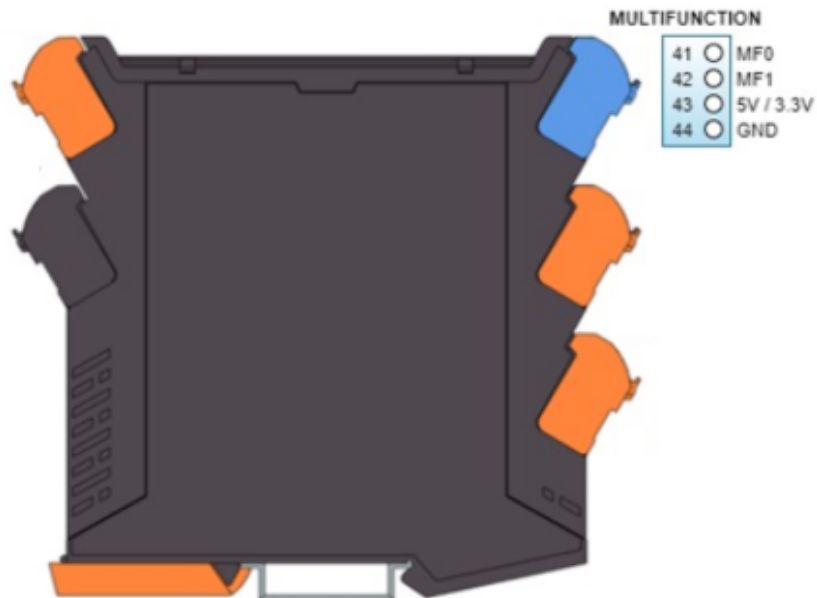

ANALOGUE / DIGITAL INPUTS	
41:	MF0
56:	MF1

The functionalities allowed in the MF0 and MF1 pins are the following:

- Can act as Digital or Analog Inputs
- Can act as Digital or Analog Outputs
- Can act as CS (Chip Select / Slave Select) on SPI communication protocol.
- Intensity and Frequency Reference Tests and Specs:

	Definition	Conditions	Typical	Unit
Vl	Low Level Voltage ¹	I=0mA, V=3.3V	55	mV
		I=5mA, V=3.3V	560	mV
		I=0mA, V=5V	70	mV
		I=5mA, V=5V	580	mV
Vh	High Level Voltage ¹	I=0mA, V=3.3V	3.3	V
		I=0mA, V=5V	5	V
Isink	Input current		5	mA
Isource	Output current ²		40	uA
Freq	Working frequency		Limited by CPU	

¹ It must be considered that there is a pull-up in the output so, if the output is not configured, the external pin will be at high level by default.

² The internal pull up resistor value is 10K Ω . The output of the MF will be able to give 5mA with a voltage of 2.5V.

Referred to the 5V/3.3V output pin:

	Definition	Conditions	Typical	Unit
Isource	Output current	V=3.3V	50	mA
		V=5V	50	mA

Referred to the switch table:

	SW1				SW2			
	1	2	3	4	1	2	3	4
RS485	x	x	x	on	off	off	on	on
UART 3.3v TTL	x	x	x	off	on	on	off	off
0 - 5v MF	on	on	on	x	x	x	x	x
0 - 3.3v MF	off	off	off	x	x	x	x	x

As described in the diagram above, switches 1, 2 and 3 are the ones needed to configure the operational voltage of the multi-function pins. If they are all in the ON position, the pins will operate at 5Vdc, while if all the switches are in the OFF position, they will operate at 3.3Vdc.

To choose the functionality of input, output or CS (Chip Select) is configured by software. Using the WIS boards in Arduino IDE, you can find examples for each MF functionality.

- Typical Connection:



3.12 Available communications

In this section of the manual, the communications, and functionalities available on the default WIS PLC models are individually listed.

3.12.1 Serial TTL (UART)

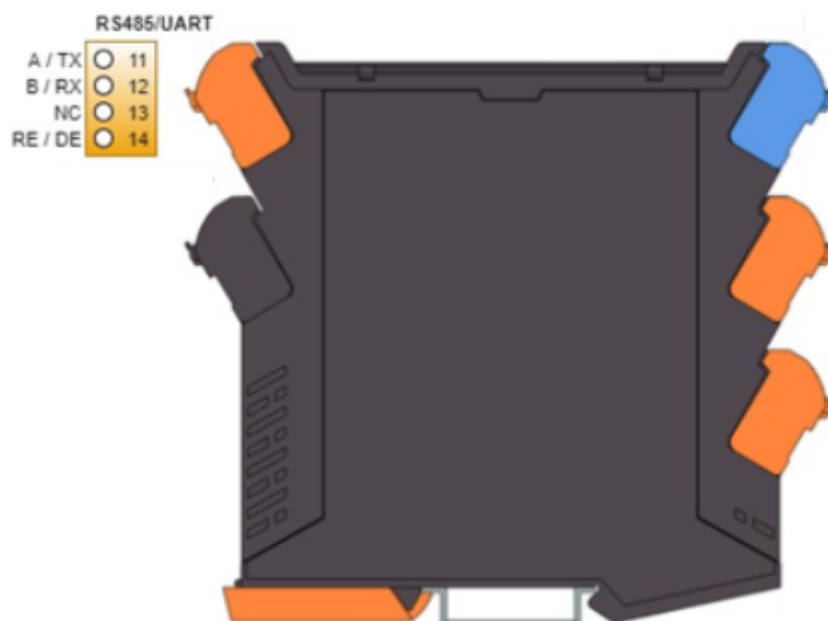

The Serial TTL pins are referred to as 11 & 12. Check the chapter 3.10 in order to know the possible switch configurations.

- Typical Connection:

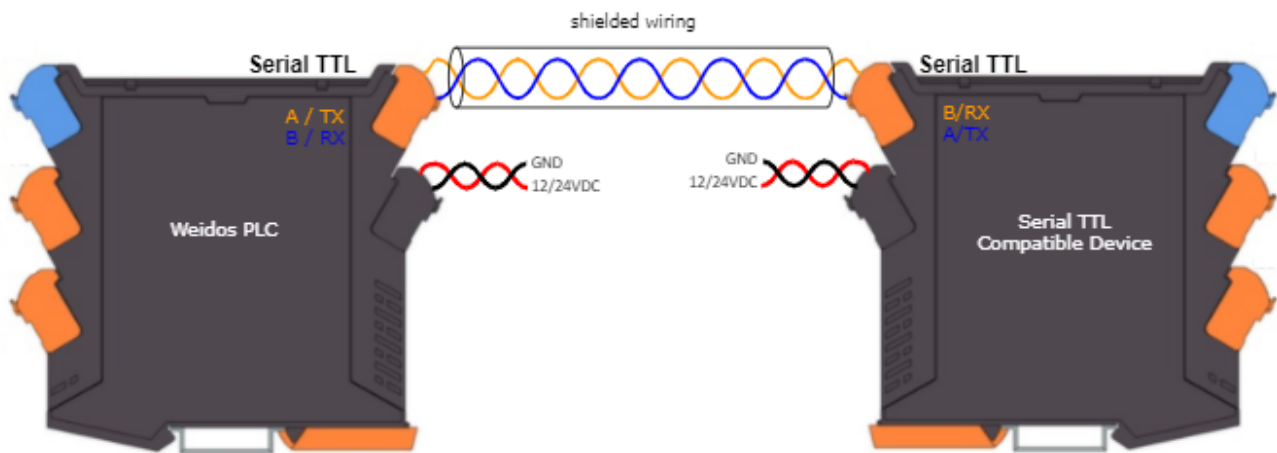

IMPORTANT: Check the switch configuration before connecting your serial devices to confirm if it is configured as RS485 pins or Serial TTL pins. These Serial TTL pins work at 3.3Vdc.

Using the WIS boards in Arduino IDE, there is a library that simplifies the Serial TTL implementation.

3.12.2 RS-485

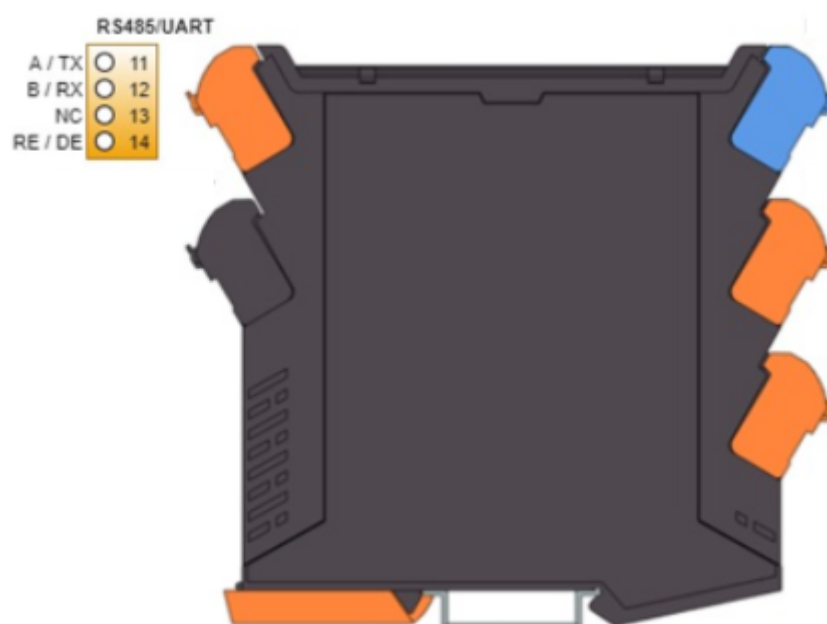

On WIS PLC family products, you can choose between three different types of Serial communication, using the same pins. Remember that in SW1, the switch number 4 needs to be at the ON position in order to allow RE / DE communication internally.

For a good performance, twisted pair and shielded wiring is required.

These pins are referred to as 11 & 12. Check the chapter 3.10 in order to know the possible switch configurations.

Using the WIS boards in Arduino IDE, there is a library that simplifies the RS-485 implementation.

- Typical Connection:

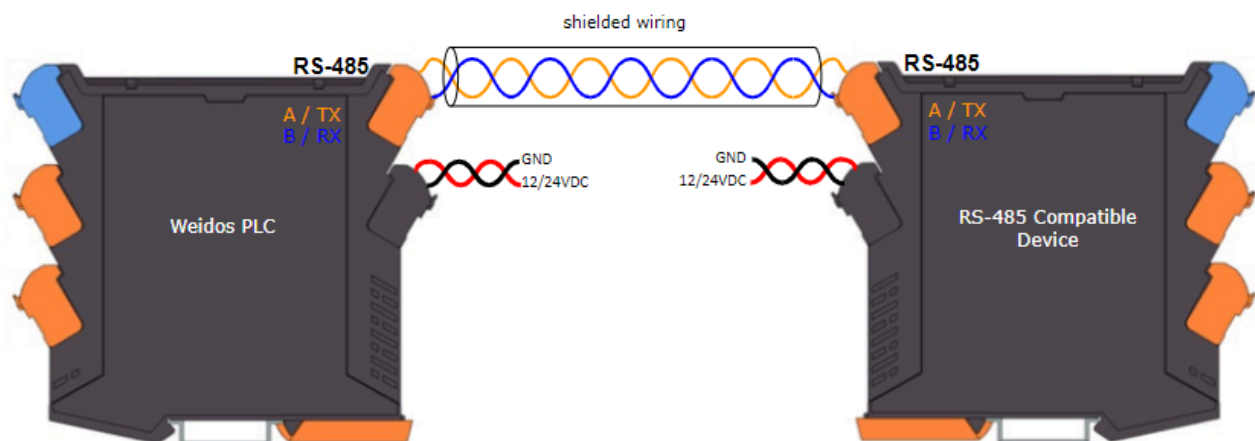

NOTE: RS-485 pins have an internal pull-up (A) and pull-down (B) of 20KΩ.

3.12.3 Ethernet

Ethernet port location on the WIS PLC Family products (Top Cover):

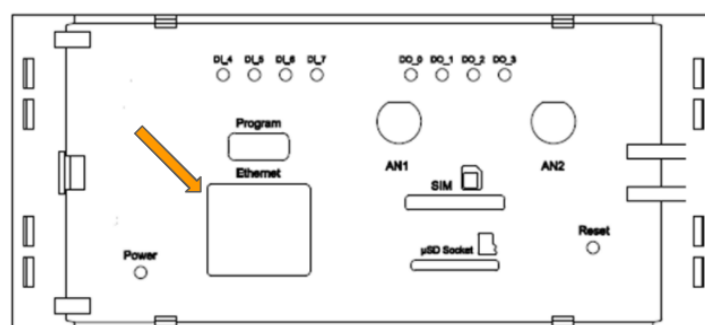

WIS Family PLCs port controller is based on w5500 IC.

All Ethernet shield Arduino and ESP32 libraries are compatible with the WIS PLC family products. In the WIS PLC Family products, W5500 IC communicates to the Internal CPU via SPI bus (CS corresponds to I2C chip MCP23008 with address 0x21 – GP7).

You can choose among multiple different protocols such as HTTP, HTTPS, MQTT, MQTTS, Modbus TCP and most of the Industrial Standards.

Using the WIS boards in Arduino IDE, there is a library that simplifies the Ethernet protocols implementation.

- Typical connection:

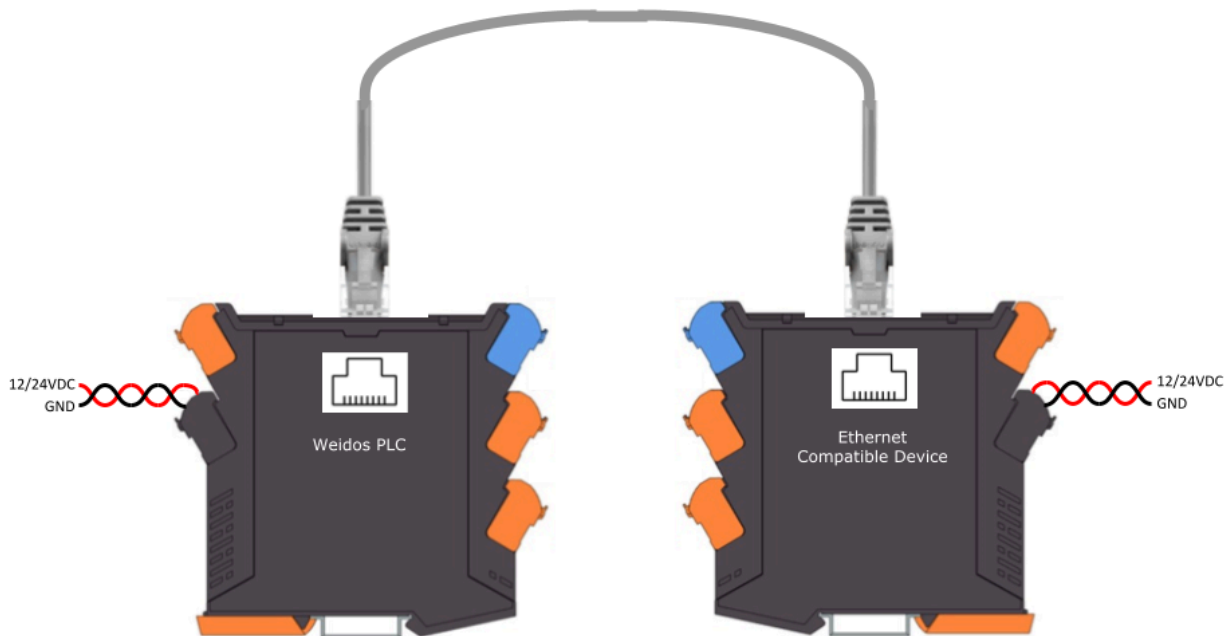

3.12.4 WiFi

The devices of the ESP32 WIS PLC controller family have integrated Wi-Fi specific programming tools to achieve simple and easy reliable programming.

Connecting to a Wi-Fi network is as easy as getting an LED to blink. You can get your board to connect to any kind of existing Wi-Fi network or use it to create your own Arduino Access Point. The specific set of examples we provide for the MKR Wi-Fi 1010 and ESP32 Wi-Fi PLC family products can be consulted at the WiFinINA library reference page adapted on the WIS boards in Arduino IDE platform. Located at File > Examples of the Arduino IDE after downloading WIS PLC Boards.

3.12.5 Bluetooth Low Energy

The communications chipset on the Nano 33 BLE Sense can be both a Bluetooth® Low Energy and Bluetooth® client and host device. If you want to see how easy it is to create a Bluetooth® central or a peripheral device, explore the examples at our Arduino BLE library that Industrial Shields provides, located at File > Examples of the Arduino IDE after downloading WIS PLC Boards.

⚠ Verify that the CPU is not actively running a process before inserting the memory card.

Inserting a memory card will cause the CPU to go to STOP mode, which could affect the operation of an online process or machine. Unexpected operation of a process or machine could result in death or injury to personnel and/or property damage. Before inserting a memory card, always ensure that the CPU is offline and in a safe state.

3.12.6 SPI

For SPI bus MISO, MOSI and CLOCK pins are common to all the connected devices to the WIS, conversely, each of the connected devices will have a single and dedicated CS pin. You can use 41:MF0 and 42:MF1 as CS pins.

The PLCs of the WIS family have a peripheral SPI port as well as internal SPI connections for communications use. Below is a wiring diagram for the internal SPI bus of WIS controllers. Note that the peripheral SPI port operates at 3.3Vdc.

3.12.6.1 Internal SPI Block Diagram for WIS PLC Series

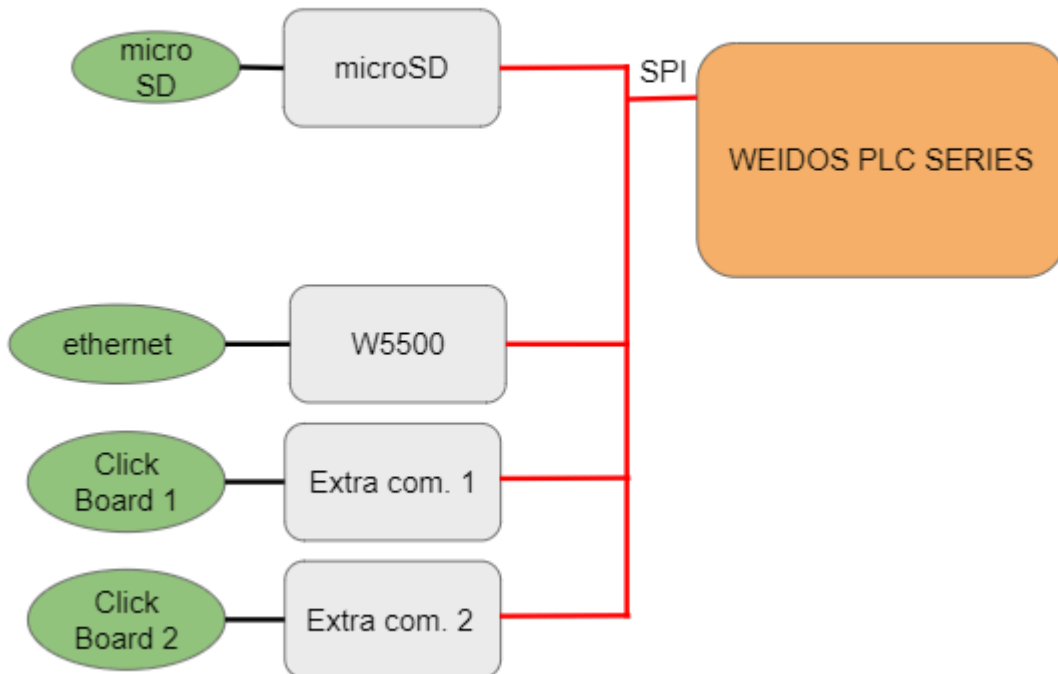

Using the WIS boards in Arduino IDE, there is a library that simplifies the SPI protocols implementation. The SPI is always referred to with the nomenclature SPI0 (the internal and the external one).

- External SPI pins location:

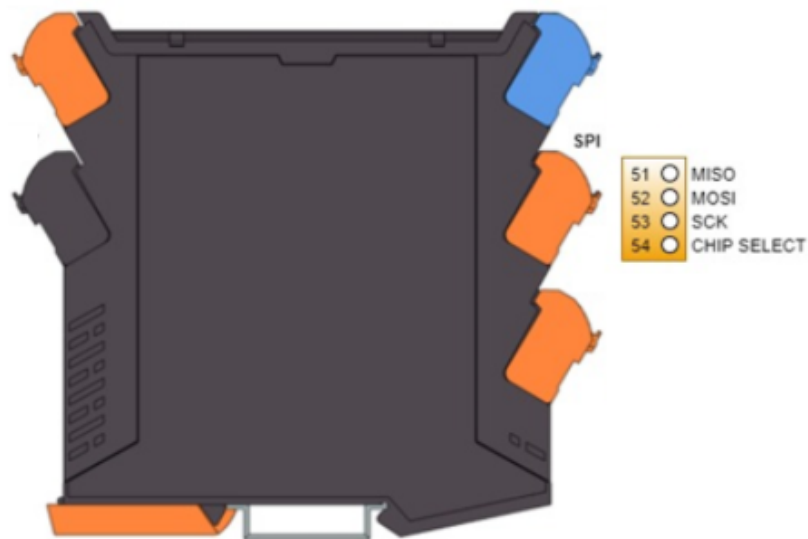

3.12.7 I2C

It is widely used for attaching lower-speed peripheral ICs to processors and microcontrollers in short-distance, intra-board communication.

I2C communication **DOES NOT REQUIRE** a pull-up resistor for the WIS PLC. The 2k Ω pull-up resistors are internally connected.

The PLCs of the WIS family have a peripheral I2C port as well as internal I2C connections for communications use. Below is a wiring diagram for the internal I2C bus of WIS controllers. Note that the peripheral I2C port operates at 3.3Vdc.

3.12.7.1 Internal I2C Block Diagram for WIS MKR1010 Series

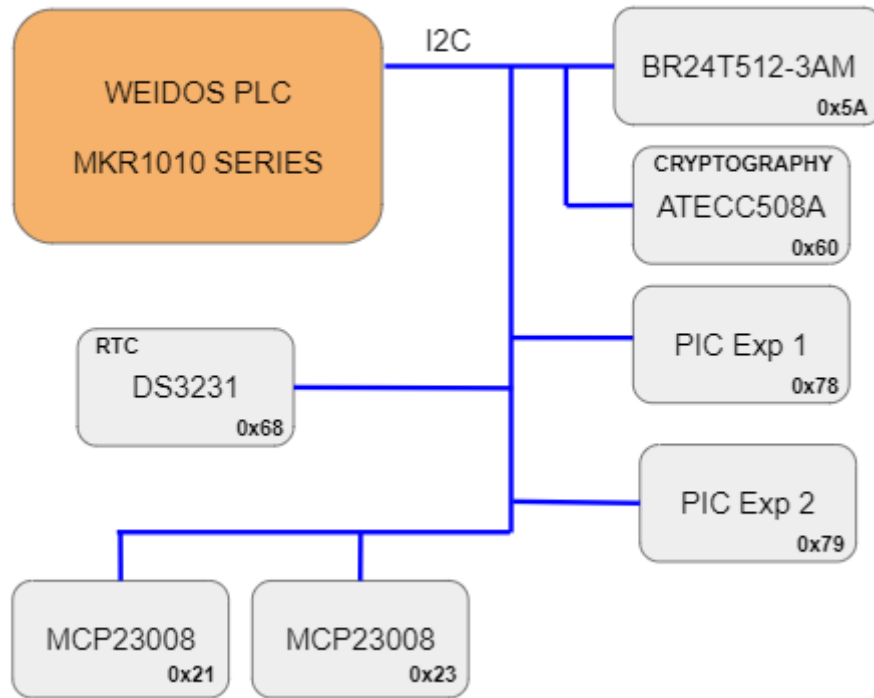

3.12.7.2 Internal I2C Block Diagram for WIS ESP32 Series

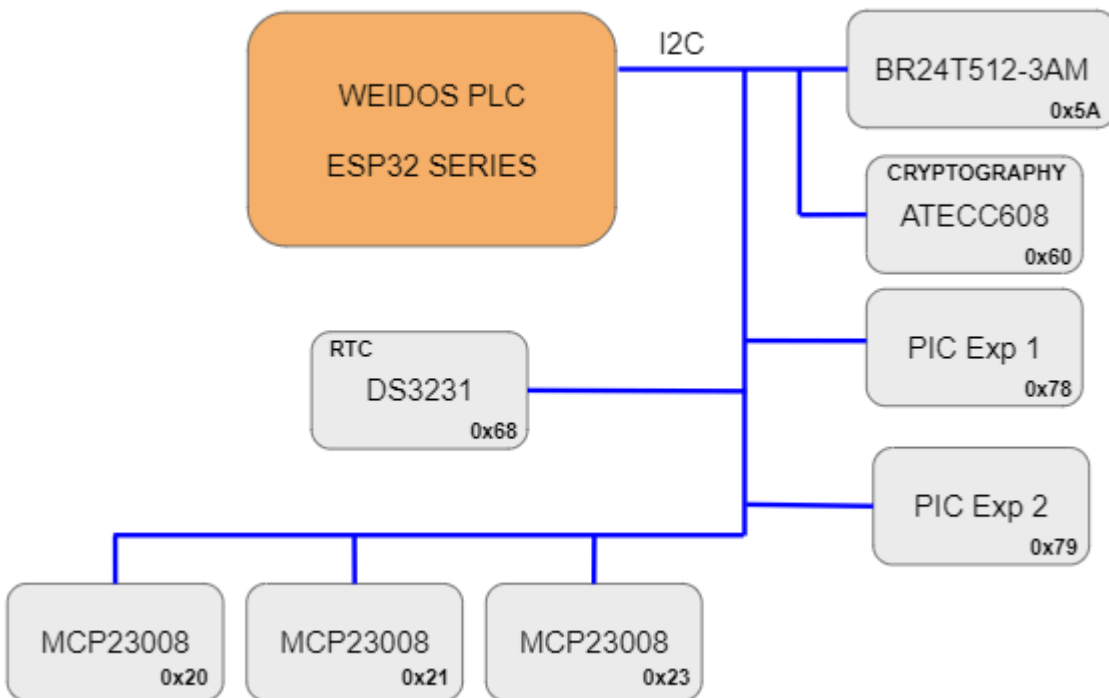

- External I2C pins location:

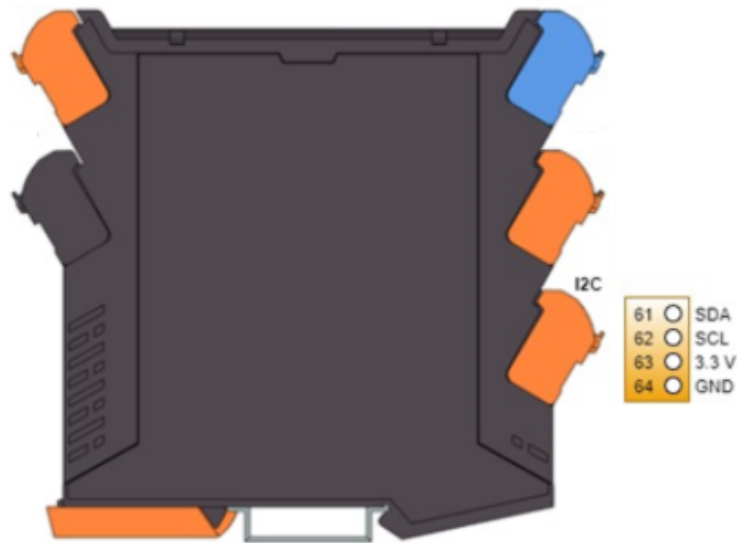

Using the WIS boards in Arduino IDE, there is a library that simplifies the I2C protocols implementation. The library is defined as Wire.h

3.13 Other functionalities

3.13.1 RTC

WIS RTC Module is based on the DS1307 Chip. This chip works with the I2C protocol communication and it's internally connected inside the PLC enclosure communicating with the CPU.

The WIS PLC family products include a 3.3Vdc cell coin located at the lower part of the PLC enclosure with an RTC serigraphy.

Using the WIS boards in Arduino IDE, there is a library that simplifies the RTC implementation.

3.13.2 EEPROM

The WIS family product has a 512KB EEPROM memory incorporated for hardcopy data writing/reading. It is very useful for storing critical constant values for the application. If it's required to record indelible data in the PLC and the recording on the microSD cards is not secure enough, the use of the EEPROM memory is allowed for this type of application.

Using the WIS boards in Arduino IDE, there is a library that simplifies the EEPROM implementation.

3.13.3 ATECC Encryption Chipset

The Microchip ATECC508A and ATECC608 integrates ECDH (Elliptic Curve Diffie Hellman) security protocol an ultra-secure method to provide key agreement for encryption/decryption, along with ECDSA (Elliptic Curve Digital Signature Algorithm) sign-verify authentication for the Internet of Things (IoT) market including home automation, industrial networking, medical, as well as accessories and consumables authentication and more. In addition, the ATECC608A offers an integrated AES hardware accelerator strengthening hardware based security for Ethernet applications and enabling secure boot capabilities.

The integration of this security chip allows the WIS PLC Series to build a secure Ethernet environment with encrypted Transport Layer Security (TLS), allowing protocols such as HTTPS, MQTTS.

Using the WIS boards in Arduino IDE, there is a library that simplifies the TLS protocol implementation.

3.13.4 uSD slot

The micro-SD uses the SPI communication to interact with the internal CPU. The SPI protocol is always enabled, as there are no switches that configure it.

The uSD socket is found in the TOP part of the PLC enclosure, so in the frontal part of the PLC, it is required to open the plastic found in the frontal part and the socket is located under the supply of the ESP32 / MKR1010.

Remember that the micro-SD card is NOT INCLUDED inside the PLC.

Using the WIS boards in Arduino IDE, there is a library that simplifies the micro-SD implementation.

3.14 Additional Communications

The following section includes all those additional communications that the WIS family of PLCs can incorporate. It should be noted that these communications do not come by default, and you must select the corresponding PLC model.

3.14.1 LoRa and LoRaWAN

Compatible with the following WIS PLC models:

- WIS-MKR1010-LORA-A1
- WIS-ESP32-NBIOT-LORA-A1

This board features the RN2483, RF technology-based SDR transceiver, which operates at a frequency of 433/868MHz from Microchip Technology. The WIS LoRa PLCs feature an embedded LoRaWAN Class A compliant stack, providing a long-range spread spectrum communication with high interference immunity.

The RN2483 module is a fully certified 433/868MHz European R&TTE directive assessed radio modem combined with the advanced and straightforward command interface. The LoRa module offers an easy and reliable solution for developing highly integrated long-range IoT networks, security systems, alarm networks, building control, M2M interfaces, and similar applications that require simple and reliable networking solutions.

Type	LoRa
Applications	Can be used for developing highly integrated long-range IoT networks, security systems, alarm networks, building control, M2M interfaces, and similar applications that require simple and reliable networking solutions.
On-board modules	RN2483 - low-power long-range RF technology-based transceiver module
Radio Region	Europe
Key Features	Embeds LoRaWAN™ Class A protocol stack. Sub-GHz, 433/868 MHz European R&TTE Directive

Description	Min	Typ	Max	Unit
Operating Frequency Range 1	433.050	-	434.790	MHz
Operating Frequency Range 2	863.000	-	870.000	MHz
UART interface baud rate	-	57600	-	bps

3.14.2 NB IoT

Compatible with the following WIS PLC models:

- WIS-MKR1010-NBIOT-A1
- WIS-ESP32-NBIOT-A1

Allows LTE Cat NB1 connectivity based on the SARA-R412M, a specialized multi-band IoT module with very low power requirements, making it perfectly suited for various IoT-based applications. Ensures data integrity between applications via secure communication protocols, notably including two-way authentication between the client and server. Its most important advantage is the ability to use already widely established cellular network infrastructures. These features make the NB IoT click a perfect choice for a wide range of IoT applications such as smart metering, bike sharing, smart parking, smart city, security and asset tracking, home appliances, agricultural and environmental monitoring, and more.

Type	GNSS,LTE IoT
Applications	Can be used for secure low-power IoT applications requiring deeper range (underground) and extended battery life.
On-board modules	Based on the SARA-R412M, an ultra-compact LTE Cat M1/NB1, and EGPRS module with multi-regional coverage with data communications up to 1200 kbit/s.
Key Features	LTE Cat M1/NB1, and EGPRS module with multi-regional coverage, low power consumption, high precision, ideal for mission-critical IoT solutions, ensures data integrity, over-the-air firmware updates, and more.

Description	Min.	Typ.	Max.	Unit.
Operating Frequency Range	850	-	1900	MHz

Using the WIS boards in Arduino IDE, there is a library that simplifies the LoRa and LoRaWAN protocols implementation.

3.14.3 Antennas

All WIS PLC family products have x2 different Antenna connectors. Both connectors are SMA Female connectors. Antenna SMA Female connectors location on the WIS PLC Family products (Top Cover):

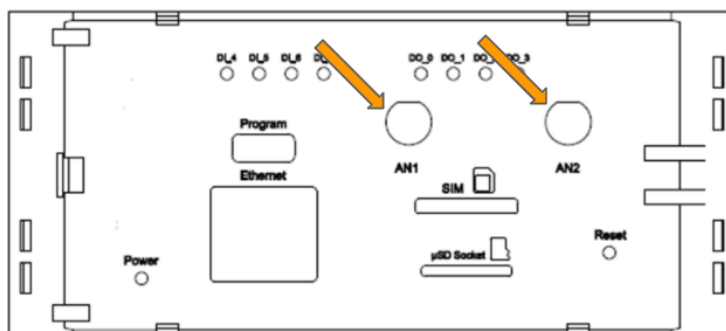

3.14.3.1 *WiFi Antennas*

In this chapter, WiFi antennas for WIS family PLCs are defined, depending on the WiFi usage.

- WIS-ANT-WIFI2400-DIPOLE-A1

For indoor operations, the following antenna is recommended:

General Information	
Reference Model Name	WIS-ANT-WIFI2400-DIPOLE-A1
Model Name	2.4GHz Wi-Fi/Bluetooth 2.3dBi Terminal Mount Hinged Omnidirectional Dipole SMA(M) Connector Antenna
Quantity needed	1 piece

Technical Data	
Electrical	
Base Frequency	2.4 Ghz
Peak Gain	2.3 dBi
Average Gain	-0.88 dBi
Communication System	Wifi (2412-2462), Bluetooth (2401-2480), Zigbee (2410-2480), 2.4 GHz ISM (2400-2483.5)
Efficiency	80%
Return Loss	-10 dB Maximum
Radiation	Omni-directional
Polarization	Linear Vertical
Power Handling	1 W
Impedance	50 Ohm
Mechanical	
Antenna Cover	TPE
Antenna Base	PC & PBT
Color	Black
Connector	SMA (Male)
Length	84 mm
Environment Conditions	
Operating Temperature	- 40 to +85°C
Storage Temperature	- 40 to +85°C
Directives	
RoHs, REACH	

- WIS-ANT-WIFI2400-EXT-A1

For outdoor Wi-Fi operations, the following antenna is recommended:

General Information	
Reference Model Name	WIS-ANT-WIFI2400-EXT-A1
Model Name	2.4GHz Wifi/Bluetooth Permanent Mount External Omnidirectional 2 meter cable SMA(M) Connector Antenna
Quantity needed	1 piece

Technical Data	
Electrical	
Base Frecuency	2.4 Ghz
Peak Gain	4,42 dBi (2400 MHz), 4,16 dBi (2450 MHz), 4,75 dBi (2500 MHz)
Average Gain	-2,48 dBi (2400 MHz), -2,69 dBi (2450 MHz), -1,98 dBi (2500 MHz)
Communication System	Wifi (2412-2462), Bluetooth (2401-2480), Zigbee (2410-2480), 2.4 GHz ISM (2400-2483.5)
Efficiency	56,5% (2400 MHz), 53,9% (2450 MHz), 63,4% (2500 MHz)
Return Loss	-15,86 dB (2400 MHz), -10,87 dB (2450 MHz), -10,23 dB (2500 MHz)
Radiation	Omni-directional
Polarization	Linear
VSWR	1,38 (2400 MHz), 1,80 (2450 MHz), 1,89 (2500 MHz)
Impedance	50 Ohm
Mechanical	
Material (Housing)	UV resistant PC
Material (Base)	Nickel plated Steel/Zinc
Color	Black
Cable	2 meters Low Loss Taoglas CFD-200
Connector	SMA (Male)
Mounting hole	20 mm (thread diameter is M18x2,5)
Recomended Torque for mounting	24,5 Nm
Maximum Torque for mounting	29,4 Nm
Weight (Antenna)	130 gr
Weight (Package)	130 gr aprox.
Dimensions (Height) mm	28,5 mm
Dimensions (Base Maximum) mm	47,8 mm
Environmental Conditions	
IP Grade	IP67 & IP69K
Temperature Range	-40°C to 85°C
Humidity	Non-condensing 65°C 95% RH
Thermal Shock	100 cycles (-40°C to +80°C)
Cable Pull	8 kgf
Directives	
RoHs, REACH	

3.14.3.2 *LoRa Antennas*

In this chapter, LoRa antennas for WIS family PLCs are defined, depending on the LoRa usage.

- WIS-ANT-LORA868-DIPOLE-A1

For indoor LoRa operations, the following antenna is recommended:

General Information	
Reference Model Name	WIS-ANT-LORA868-DIPOLE-A1
Model Name	868-915 MHz ISM Band Terminal Mount Fixed Right-Angle Omnidirectional Dipole SMA(M) Connector Antenna
Quantity needed	1 piece

Technical Data	
Electrical	
Base Frequency	868 MHz & 915 MHz
Peak Gain	1.75 dBi (863-870), 2.43 dBi (902-928)
Average Gain	-2.74 dBi (863-870), -2.26 dBi (902-928)
Communication System	ISM (863-870 MHz & 902-928 MHz)
Efficiency	53.22% (863-870), 59.37% (902-928)
Radiation	Omni-directional
Polarization	Linear
VSWR	50 W
Impedance	50 Ohm
Mechanical	
Casing	TPU
Color	Black
Connector	SMA (Male) Right Angle
Dimensions (Height x Width x Diameter) mm	53 x 17 x 7
Environmental Conditions	
Temperature Range	-40°C to +70°C
Directives	
RoHs, REACH	

- WIS-ANT-LORA868-EXT-A1

For outdoor LoRa operations, the following antenna is recommended:

General Information	
Reference Model Name	WIS-ANT-LORA868-EXT-A1
Model Name	868-915 MHz ISM Band Permanent Mount External Omnidirectional 2 meter cable SMA(M) Connector Antenna
Quantity needed	1 piece

Technical Data	
Electrical	
Base Frequency	868 MHz & 915 MHz
Peak Gain (with ground plane 30 x 30 cm)	1.58 dBi (868), 1.9 dBi (915)
Average Gain (with ground plane 30 x 30 cm)	-2.17 dBi (868), --1.89dBi (915)
Communication System	ISM (850-880 MHz & 902-928 MHz)
Efficiency	60.67% (868), 64.71% (915)
Return Loss	- 20 dB Maximum
Radiation	Omni-directional
Polarization	Linear
Input Power	100 W
Impedance	50 Ohm
Mechanical	
Material (Housing)	UV Resistant ABS
Material (Base)	Nickel Plated Zinc Alloy
Color	Black
Cable	2 meters Low Loss Taoglas TGC-200
Connector	SMA (Male)
Mounting hole	5/8" (M16)
Recomended Torque for mounting	4.018 Nm
Maximum Torque for mounting	9.8 Nm
Ground Plane	30 x 30 cm
Weight (Antenna)	245 gr
Weight (Package)	370 gr
Dimensions (Height) mm	79,45 mm
Dimensions (Base Maximum) mm	42 mm
Environmental Conditions	
IP Grade	IP67 & IP69K
Temperature Range	-40°C to 70°C
Humidity	Non-condensing 65°C 95% RH
Directives	
RoHs, REACH	

3.14.3.3 Cellular Antennas

- WIS-ANT-CELLULAR-MONOPOLE-A1

In this chapter, WiFi antennas for WIS family PLCs are defined, depending on the usage.

General Information	
Reference Model Name	WIS-ANT-CELLULAR-MONOPOLE-A1
Model Name	600MHz-6GHz Cellular Band Terminal Mount 90° Hinged Omnidirectional Monopole SMA(M) Connector Antenna
Quantity needed	1 piece

Technical Data	
Electrical	
Base Frequency	600 MHz to 6 GHz
Peak Gain (free space straight/bent)	-0,68/0,14 dBi (5G NR Band 71 617~698 MHz), -2,14/-1,88 dBi (LTE 700 698~824 MHz), 0,15/0,58 dBi (GSM850/900 824~960 MHz), -0,74/0,87 dBi (5G NR B 74, 75, 76 1427~1518 MHz), -0,59/1,98 dBi (GPS L1 1563~1587 MHz), 1,37/3,09 dBi (DCS 1710~1880 MHz), 0,93/2,45 dBi (UMTS1 1920~2170 MHz), 0,73/1,69 dBi (LTE 2600 2300~2690 MHz), 1,51/1,5 dBi (5G NR B 77, 78, 79 3300~5000 MHz), 1,73/0,70 dBi (LTE 5200 5150~5925 MHz)
Average Gain (free space straight/bent)	-4,45/-3,59 dBi (5G NR Band 71 617~698 MHz), -5,86/-5,15 dBi (LTE 700 698~824 MHz), -4,16/-2,86 dBi (GSM850/900 824~960 MHz), -4,19/-3,54 dBi (5G NR B 74, 75, 76 1427~1518 MHz), -3,34/-2,75 dBi (GPS L1 1563~1587 MHz), -1,56/-1,08 dBi (DCS 1710~1880 MHz), -2,29/-1,87 dBi (UMTS1 1920~2170 MHz), -3,48/-2,88 dBi (LTE 2600 2300~2690 MHz), -2,97/-3,11 dBi (5G NR B 77, 78, 79 3300~5000 MHz), -3,38/-4,56 dBi (LTE 5200 5150~5925 MHz)
Communication System	Cellular (600MHz-6 GHz)
Efficiency (free space straight/bent)	35,93/43,77 % (5G NR Band 71 617~698 MHz), 25,92/30,56 % (LTE 700 698~824 MHz), 38,33/51,77 % (GSM850/900 824~960 MHz), 38,08/44,23 % (5G NR B 74, 75, 76 1427~1518 MHz), 46,37/53,07 % (GPS L1 1563~1587 MHz), 69,80/78,02 % (DCS 1710~1880 MHz), 59,03/65,02 % (UMTS1 1920~2170 MHz), 44,92/51,53 % (LTE 2600 2300~2690 MHz), 50,45/48,91 % (5G NR B 77, 78, 79 3300~5000 MHz), 45,96/34,98 % (LTE 5200 5150~5925 MHz)
Radiation	Omni-directional
Polarization	Linear
Input Power	2 W
Impedance	50 Ohm

Mechanical	
Casing	ABS + PC
Color	Black
Weight	24,3 gr
Connector	SMA (Male) Right Angle
Dimensions (Height x Width) mm	172 x 23.88
Environmental Conditions	
Temperature Range	-40°C to +70°C
Humidity	Non-condensing 65°C 95% RH
Directives	
RoHs, REACH	

- WIS-ANT-LORA868-EXT-A1

For outdoor LoRa operations, the following antenna is recommended:

General Information	
Reference Model Name	WIS-ANT-CELLULAR-EXT-A1
Model Name	600MHz-6GHz Cellular Permanent Mount External Omnidirectional 2 meter cable SMA(M) Connector Antenna
Quantity needed	1 piece

Technical Data	
Electrical	
Base Frequency	600 MHz to 6 GHz
Peak Gain (with ground plane 30 x 30 cm)	1,3 dBi (5G/4G Band 71 617-698 MHz), 0,6 dBi (4G/3G Band 12,13,14,17,28,29 698-806 MHz), 1,4 dBi (4G/3G Band 5,18,19,20,26,27 824-960 MHz), -1,2 dBi (5G/4G Band 21,32,74,75,76 1427~1518 MHz), 1,1 dBi (4G/3G Band 1,2,3,4,9,23,25,35,39,66 1710~2200 MHz), -1,9 dBi (4G/3G Band 7,30,38,40,41 2300~2690 MHz), -3,5 dBi (5G NR, Band 22, 42, 48, 77, 78, 79 3300~4200 MHz)
Average Gain (with ground plane 30 x 30 cm)	-6,7 dBi (5G/4G Band 71 617-698 MHz), -4,4 dBi (4G/3G Band 12,13,14,17,28,29 698-806 MHz), -3 dBi (4G/3G Band 5,18,19,20,26,27 824-960 MHz), -6,4 dBi (5G/4G Band 21,32,74,75,76 1427~1518 MHz), -3,3 dBi (4G/3G Band 1,2,3,4,9,23,25,35,39,66 1710~2200 MHz), -6,4 dBi (4G/3G Band 7,30,38,40,41 2300~2690 MHz), -8,7 dBi (5G NR, Band 22, 42, 48, 77, 78, 79 3300~4200 MHz)
Communication System	600 MHz to 6 GHz
Efficiency	21,4 % (5G/4G Band 71 617-698 MHz), 36,7 % (4G/3G Band 12,13,14,17,28,29 698-806 MHz), 49,8 % (4G/3G Band 5,18,19,20,26,27 824-960 MHz), 23,1 % (5G/4G Band 21,32,74,75,76

	1427~1518 MHz), 45,6 % (4G/3G Band 1,2,3,4,9,23,25,35,39,66 1710~2200 MHz), 23,2 % (4G/3G Band 7,30,38,40,41 2300~2690 MHz), 14% (5G NR, Band 22, 42, 48, 77, 78, 79 3300~4200 MHz)
Return Loss	Omni-directional
Radiation	Linear
Polarization	2 W
Input Power	50 Ohm
Impedance	600 MHz to 6 GHz
Mechanical	
Material (Housing)	ABS+ Anti-UV
Material (Base)	Brass with nickel plated
Color	Black
Cable	2 meters Taoglas RG-174
Connector	SMA (Male) Right Angle
Mounting hole	M12
Ground Plane	30 x 30 cm
Weight (Antenna)	75 gr
Dimensions (Height) mm	48,5 mm
Dimensions (Diameter) mm	50,15 mm
Environmental Conditions	
IP Grade	IP67
Impact Grade	IK10
Temperature Range	- 40 to +85°C
Humidity	Non-condensing 65°C 95% RH
Thermal Shock	200 cycles -40°C to +90°C
Cable pull	8kgf
Directives	
RoHs, REACH	

4 Software Programming

4.1 Connect WIS to PC

Micro USB Port location on the WIS PLC Family products (Top Cover):

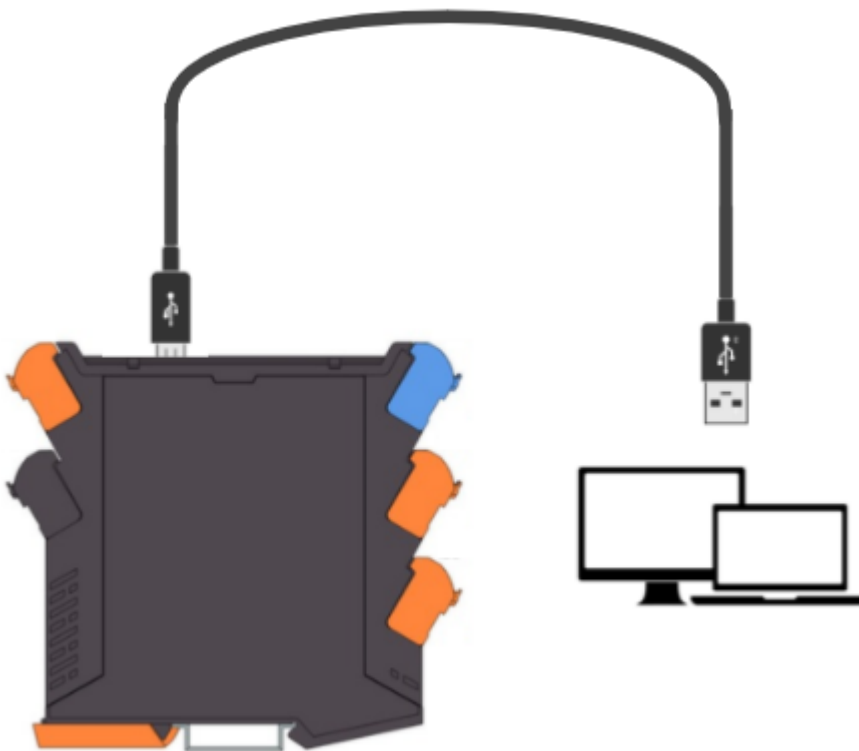
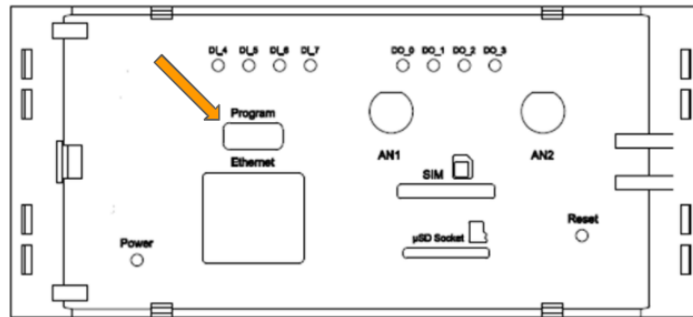

- Connect micro USB 2.0 port from PLC to PC or Laptop.

NOTE:
PLC 10 I/Os Family requires micro USB 2.0 cable.



4.2 Arduino IDE

The products of the control series are programmable logic controllers. The WIS controllers are configured, parameterized, and programmed using the Arduino IDE platform. You can download the Arduino IDE platform for any Operative System directly from this [site](#).

The steps to follow to install our equipment's to Arduino IDE are:

- 1- Open the Arduino IDE, version 1.8.13 or superior.
- 2- Press the "Preferences" option to the "File" menu and open the preferences window.
- 3- In the text box "Additional boards manager URLs", add the direction:

http://apps.industrialshields.com/main/arduino/boards/package_industrialshields_index.json

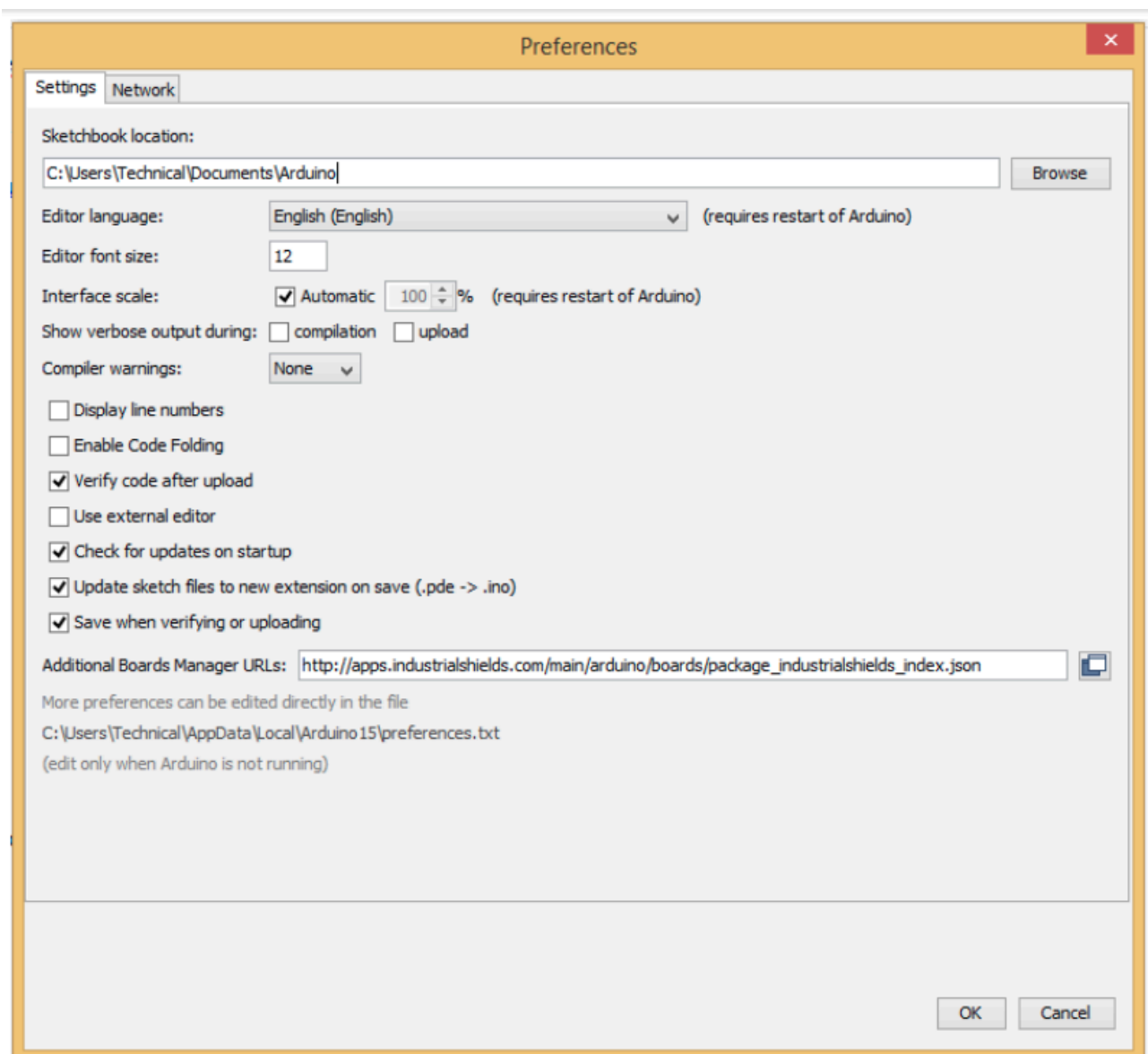

4- Close the preferences window with the “Ok” button.

5- Click on the “Tools” menu, and open the “Boards” submenu, and click the “Boards Manager” option, to open the Boards Manager window.

6- Search “industrialshields” to the search filter and select both “industrialshields-wis-esp32” and “industrialshields-wis-samd” and click “Install”.

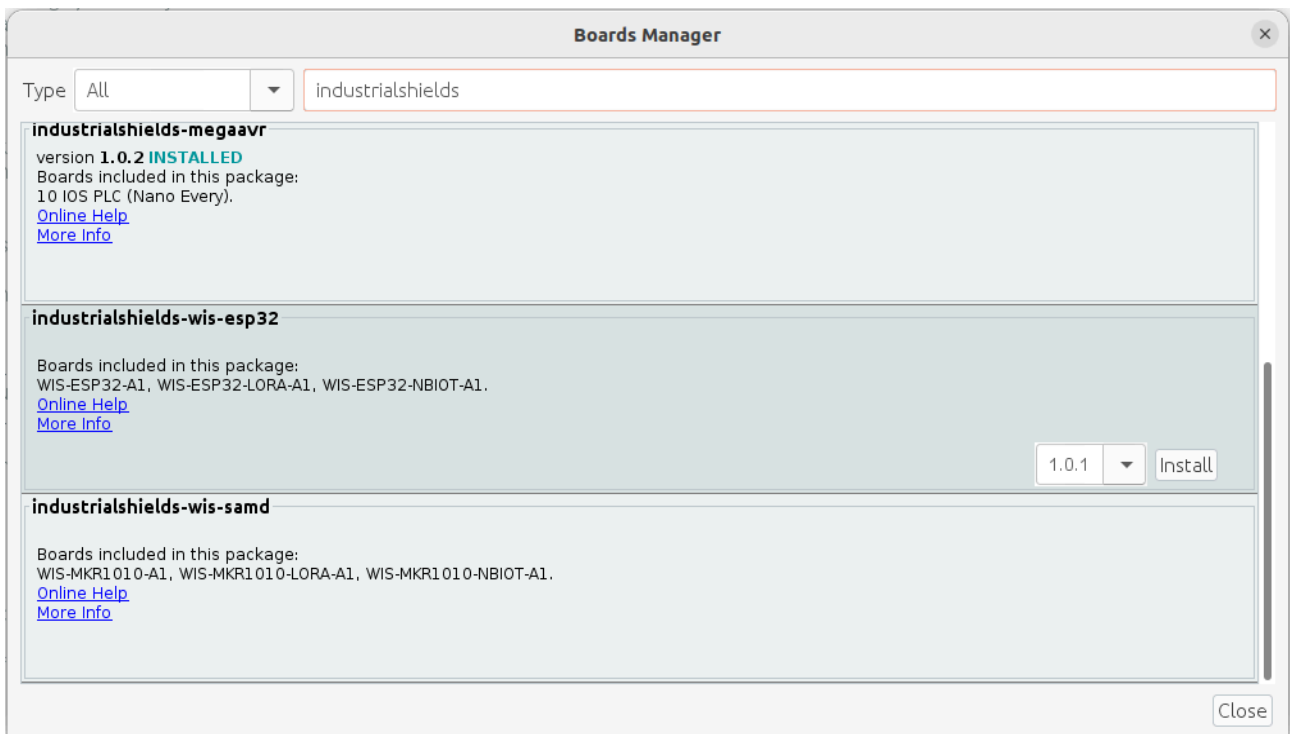

7- Close the “Boards Manager”.

Once it is performed that steps, you are available to select your concrete PLC Model on Arduino IDE platform and start programming your WIS PLC following the instructions represented on the image that you can find below.

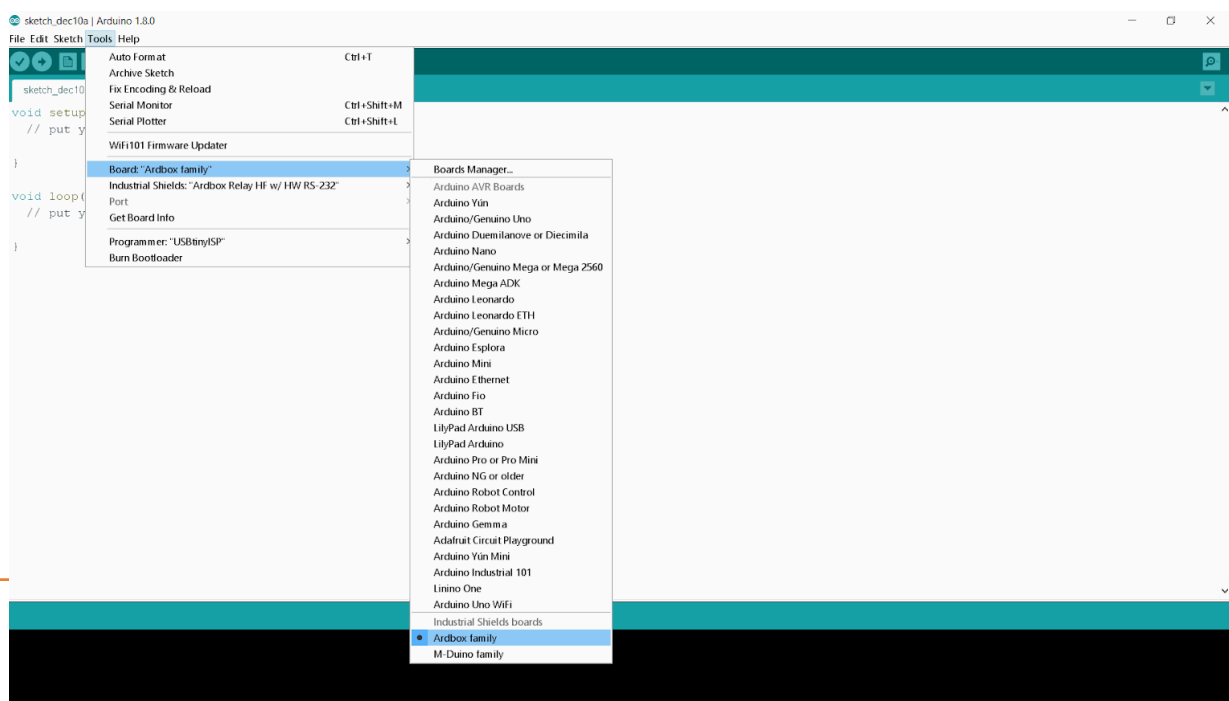

Once the board and the corresponding PLC model have been selected, you will be able to access programming examples for each of the communications and protocols that can be used in this family of PLCs.

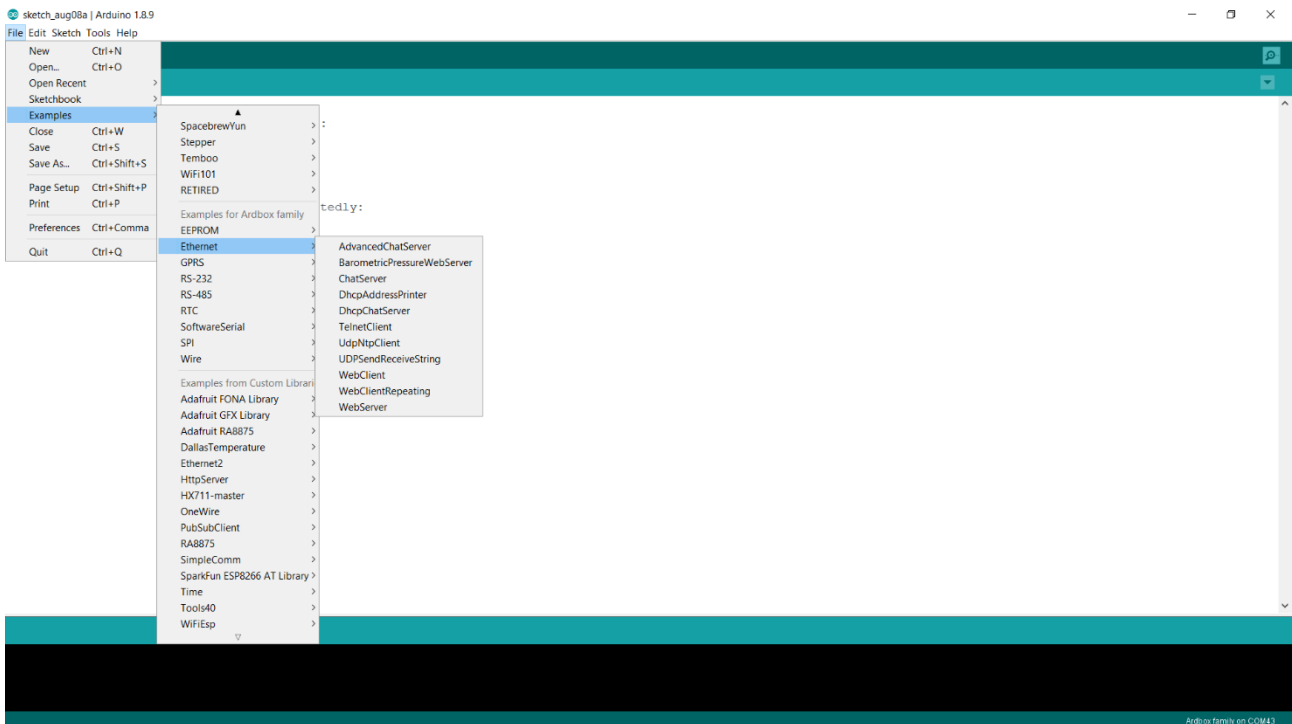

5 Installation & Maintenance

Notes for installation:

- The installation position should be free from the following: dust or oil smoke, conductive dust, corrosive or flammable gas, high temperature, condensation, and rain.
- Besides, vibration and impact also affect the PLC normal operation and shorten its lifespan; electric shock, fire or misact also damages the product. During drilling or wiring, prevent the metal particles or wire segments from falling into the PLC casing, which may cause fire, fault or misact.
- After the PLC installation, clean the ventilation duct to prevent blocking, which may cause bad ventilation, or even fire, faults, or misact.
- Do not online connect, plug or unplug cables, which is apt to cause electric shock or damage the circuit. Installation and wire connection must be firm and reliable. Poor connection could cause a misact.
- Use a shielded twisted pair for the I/O of high frequency signal and analog signal to improve system IMS.

The installation environment should be free from dust, oil smoke, conductive particles, corrosive or flammable gases, high temperature, condensation and rain.

Besides, vibration and impact also affect the PLC normal operation and shorten its lifespan. It is recommended to install the PLC, together with the matching switches and contactors, in a dedicated electric cabinet and keep the cabinet ventilated. If the location has high ambient temperature or heat generating equipment nearby, install forced convection devices on top or sides of the cabinet to avoid over-temperature. During drilling or wiring, prevent the metal particles or wire segments from falling into the PLC casing, which may cause fire, fault, or misact. After the PLC installation, clean the ventilation duct to prevent blocking, which may cause bad ventilation, or even fire, faults, or misact.

The only way to disconnect the equipment from the electrical network is by removing the connectors that feed the equipment. Once installed in the electrical cabinet it is very important to ensure the power connectors for proper operation.

Separate the WIS PLC from heat, high voltage, and electrical noise:

Always separate the devices that generate high voltage and high electrical noise from the WIS PLC. When configuring the layout of the WIS PLC inside your panel, consider the heat-generating devices and locate the electronic-type devices in the cooler areas of your cabinet. Reducing the exposure to a high-temperature environment will extend the operating life of any electronic device. Also consider the routing of the wiring for the devices in the electric cabinet. Avoid placing low-voltage signal wires and communications cables in the same tray with AC power wiring and high energy, rapidly switched DC wiring.

Provide adequate clearance for cooling and wiring WIS. Is designed for natural convection cooling. For proper cooling, you must provide a clearance of at least 20 cm above and below the devices. Also, allow at least 20 cm of depth between the front of the modules and the inside of the enclosure.

Notes for maintenance:

A well-planned and executed maintenance program is essential to the satisfactory operation of solid-state electrical equipment. The kind and frequency of the maintenance operation will vary with the kind and complexity of the equipment as well as with the nature of the operating conditions. Maintenance recommendations of the manufacturer or appropriate product standards should be followed.

The following factors should be considered when formulating a maintenance program:

- Maintenance must be performed by qualified personnel familiar with the construction, operation, and hazards involved with the control.
- Maintenance should be performed with the control out of operation and disconnected from all sources of power.
- Care should be taken when servicing electrostatic sensitive components. The manufacturer's recommendations for these components should be followed.
- Ventilation passages should be kept open. If the equipment depends upon auxiliary cooling, e.g., air, water, or oil, periodic inspection (with filter replacement when necessary) should be made of these systems.
- The means employed for grounding or insulating the equipment from ground should be checked to assure its integrity.
- Accumulations of dust and dirt on all parts, including on semiconductor heat sinks, should be removed according to the manufacturer's instructions, if provided; otherwise, the manufacturer should be consulted. Care must be taken to avoid damaging any delicate components and to avoid displacing dust, dirt, or debris in a way that permits it to enter or settle into parts of the control equipment.
- Enclosures should be inspected for evidence of deterioration. Accumulated dust and dirt should be removed from the top of the enclosures before opening doors or removing covers.
- Certain hazardous materials removed as part of maintenance or repair procedure (e.g., polychlorinated biphenyls (PCBs) found in some liquid filled capacitors) must be disposed of as described in Federal regulations.

Safety rules for maintenance personnel

Consider the following steps to follow. A false maneuver could be the cause of an accident or material damage.

Do not disassemble or modify the modules. This could lead to breakdowns or malfunctions and could lead to injuries or fire.

- All types of radio communication devices, including mobile phones and personal handy-phone systems (PHS), must be kept more than 25 cm away from the PLC in all directions. Failure to observe this precaution exposes malfunctions caused by excess temperature.
- Disconnect the external power supply of the system (on all phases) before connecting or disconnecting a module. Failure to observe this precaution may cause faults or malfunctions of the module.

- Tighten the screws of the terminal ports and the screws of the connectors within the prescribed tightening torque. Insufficient tightening can lead to loose parts or wires and cause malfunctions. Excessive tightening can damage the screws and / or the module, with the risk of falling, short circuits and malfunctions.
- Before handling a module, dispose of the electrostatic charge accumulated by the human body by touching a suitable conductive object. Failure to observe this precaution may cause faults or malfunctions of the module.

Repair note:

If the equipment is suitable to be repaired, it must be verified that the equipment remains in a safe state after repair.