



INDUSTRIAL SHIELDS

## DIN Rail Power Supply Unit

### 40W, 12V Output

- Universal Input 85 - 264 Vac
- Cooling by Free Air convection
- Protections against: Overload and Over Voltage



# Power Supply Unit

**Revised October 2022**

## Preface

This User Guide is been implemented by Boot & Work, S.L. working under the name Industrial Shields.

### **Purpose of the manual**

The information contained in this manual can be used as a reference to operating, to functions, and to the technical data of the signal modules, power supply modules and interface modules.

### **Intended Audience**

This User Guide is intended for the following audience:

- Persons in charge of introducing automation devices.
- Persons who design automation systems.
- Persons who install or connect automation devices.
- Persons who manage working automation installation.

## Intended use or of Industrial Shields products

Consider the following:

Industrial Shields products should only be used for the cases of application foreseen in the catalogue and the associated technical documentation. If third-party products and components are used, they must have been recommended or approved by Industrial Shields.

The correct and safe operation of the products requires that your transport, storage, installation, assembly, operation and maintenance have been carried out in a correct It must respect the permissible ambient conditions. You should also follow the indications and warnings that appear in the associated documentation.

The product / system dealt with in this documentation should only be handled or manipulated by qualified personnel for the task entrusted and observing what is indicated in the documentation corresponding to it, particularly the safety instructions and warnings included in it. Due to their training and experience, qualified personnel are in a position to recognize risks resulting from the handling or manipulation of such products / systems and to avoid possible hazards.

## Disclaimers

### Weights and Dimensions

Dimensions and weights are nominal and they are not used for manufacturing purposes, even when tolerances are shown.

### Performance Data

The performance data given in this manual is provided as a guide for the user in determining suitability and does not constitute a warranty. It may represent the result of INDUSTRIAL SHIELDS's test conditions, and the users must correlate it to actual application requirements. Actual performance is subject to the INDUSTRIAL SHIELDS Warranty and Limitations of Liability.

### Change in Specifications

Product specifications and accessories may be changed at any time based on improvements and other reasons.

It is our practice to change model numbers when features are changed, or published ratings or when significant construction changes are made. However, some specifications of the products may be changed without any notice. When in doubt, special numbers may be assigned to fix or establish key specifications for your

application on your request. Please consult with your INDUSTRIAL SHIELDS representative at any time to confirm actual specifications of purchased products.

## Errors and Omissions

The information in this document has been carefully checked and is believed to be accurate; however, no responsibility is assumed for clerical, typographical, or proofreading errors, or omissions.

These components may only be operated in closed housings or in higher-level control cabinets with protective covers that are closed, and when all of the protective devices are used. These components may only be handled by qualified and trained technical personnel who are knowledgeable and observe all of the safety information and instructions on the components and in the associated technical user documentation. When carrying out a risk assessment of a machine in accordance with the EU Machinery Directive, the machine manufacturer must consider the following residual risks associated with the control and drive components of a PDS.

# Table of Contents

<b>1 General Description</b>	<b>5</b>
1.1. Electrical	5
1.2. Input Parameters	5
1.3. Output Parameters	6
1.4. Protection	6
1.5. Mechanical dimension	7
1.6. Serigraphy	7
<b>2 Operating Specifications:</b>	<b>8</b>
2.1 Environment	8
2.2. Safety/EMC	8
<b>3 Block diagram</b>	<b>9</b>
<b>4 Derating Curve</b>	<b>9</b>
<b>5 Output Derating VS Input Voltage</b>	<b>10</b>



## 1 General Description

### 1.1. Electrical

Nominal Input Voltage	Output Voltage	Output Current	Ripple (Typ.) and Noise *Note 2	Efficiency (Typ.)
240 Vac (Leakage Current = < 1mA)	12 Vdc	3.33 A	120mVp-p	86%

**Note 1:** All parameters NOT specially mentioned are measured at 230VAC input, rated load and 25°C of ambient temperature.

**Note 2:** Ripple & noise are measured at 20MHz of bandwidth by using 1 12" twisted pair-wire terminated with a 0.1uF & 47uF parallel capacitor.

### 1.2. Input Parameters

PARAMETER	CONDITIONS	MIN	TYP	MAX	UNITS
Input Voltage		85		264	Vac
		120		370	Vdc
Input Frequency		47		63	Hz
Input Current	Full load, Vin = 115Vac		1,1		A
	Full load, Vin = 230Vac		0,7		A
Inrush Current	Cold start, Vin = 115Vac			30	A
	Cold start, Vin = 230Vac			60	A

### 1.3. Output Parameters

PARAMETER	CONDITIONS	MIN	TYP	MAX	UNITS
Output Voltage tolerance <b>*Note 3</b>			±1		%
Output Voltage adjustment range			12-15		Vdc
Current range		0		3.33	A
Line regulation			±1		%
Setup, rise time <b>*Note 4</b>	Vin =230 Vac Full load, Vin = 115 Vac		500, 30 500, 30		ms
Hold up time	Vin =230 Vac Full load, Vin = 115 Vac		50 20		ms

**Note 3:** Tolerance: includes set up tolerance, line regulation and load regulation.

**Note 4:** Length of set up time is measured at first cold start. Turning ON/OFF the power supply may lead to increase of the set up time.

### 1.4. Protection

<b>Over Voltage</b>	Over Voltage protection value 15.6V - 18V
	Protection type: Shut down o/p voltage, re-power on to recover.
<b>Overload</b>	105 ~ 150% rated output power.
	Protection type: Constant current limiting, recovers automatically after fault condition is removed.

## 1.5. Mechanical dimension

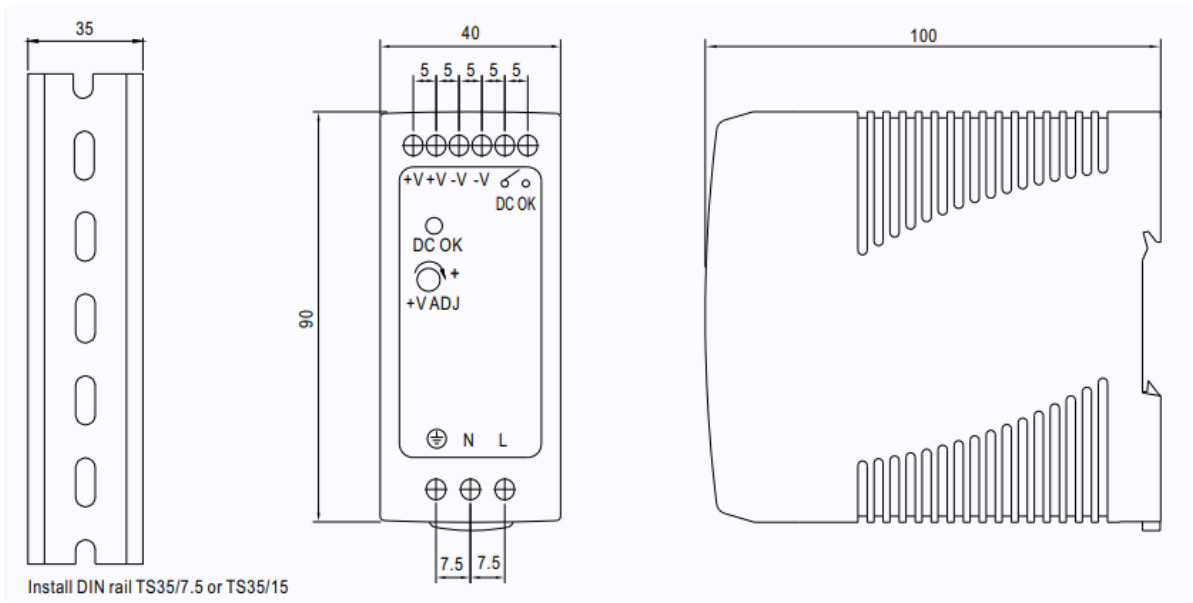

Unit: mm

Tolerance  $\pm 1.0$

## 1.6. Serigraphy

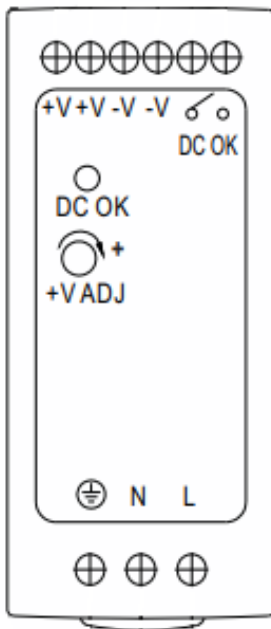

Marking	No.	Assignment
+	1	DC(+) Output Terminal
+	2	
-	3	DC(-) Output Terminal
-	4	
L	5	AC(L) Input Terminal
N	6	AC(N) Input Terminal
⊕	7	AC Grounding Terminal
V-ADJ.	/	DC Output voltage adjustment trimmer
DC OK	/	DC Output OK indication LED(Green)



## 2 Operating Specifications:

### 2.1 Environment

PARAMETER	CONDITIONS	MIN	TYP	MAX	UNITS
Ambient Operating temperature	Startup at rated voltage	-20		60	°C
Operating Relative humidity	Non Condensing	20		90	% RH
Storage Temperature	Humidity 10 - 95% RH	-40		85	°C
Cooling	Free air convection				
Mounting Method	Vertical				
Dimensions (WxHxD)	40.0 x 90.0 x 100.0 mm ( 1.57 x 3.54 x 3.93 inch)				
Weight	300 g				
Packing	42pcs / 13.6Kg / 0.82cuft / carton				

### 2.2. Safety/EMC

<b>Withstand Voltage</b>	I/P-O/P: 1.5KVac, I/P-FG: 1.5KVac, O/P-FG: 0.5KVac
<b>Isolation Resistance</b>	100MΩ Max. / 500Vdc / 25°C / 70%RH
<b>Safety</b>	Design refer to UL60950-1, Class I

<b>EMC *Note 5</b>	EMC Emission: Compliance to EN55011, EN55022 (CISPR32) EMC Immunity: Compliance to EN61000-4-2, 3, 4, 5, 6, 8, 11
--------------------	--

**Note 5:** The power supply is considered a component which will be installed into a final equipment. The final equipment must be re-confirmed that it still meets EMC directives. For guidance on how to perform these EMC tests, please refer to “EMI testing of component power supplies”.

### 3 Block diagram

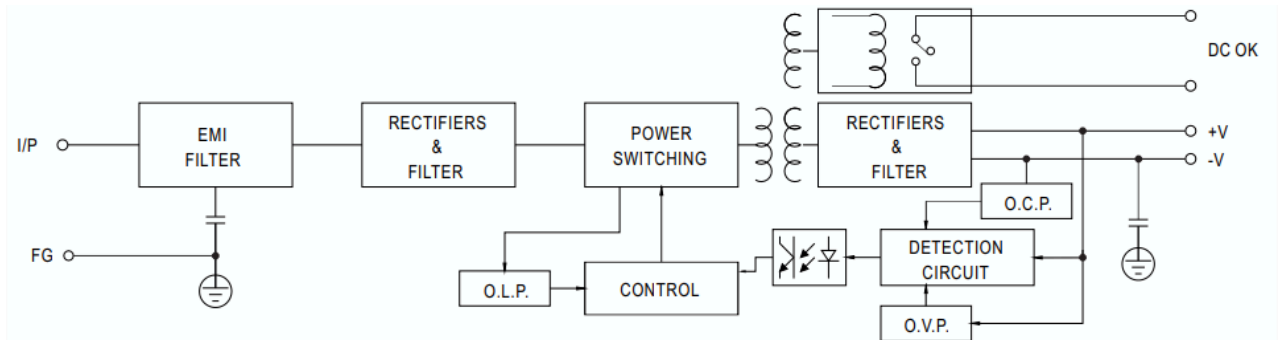

### 4 Derating Curve

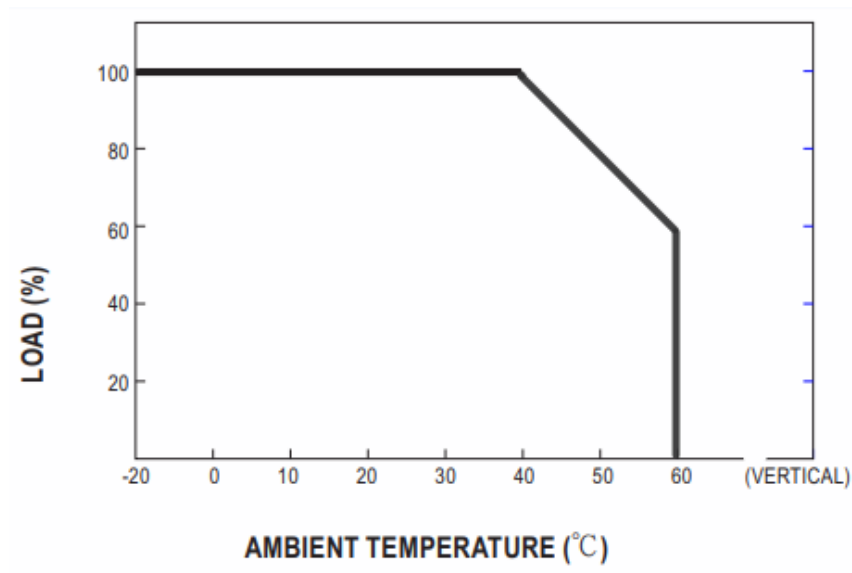

## 5 Output Derating VS Input Voltage

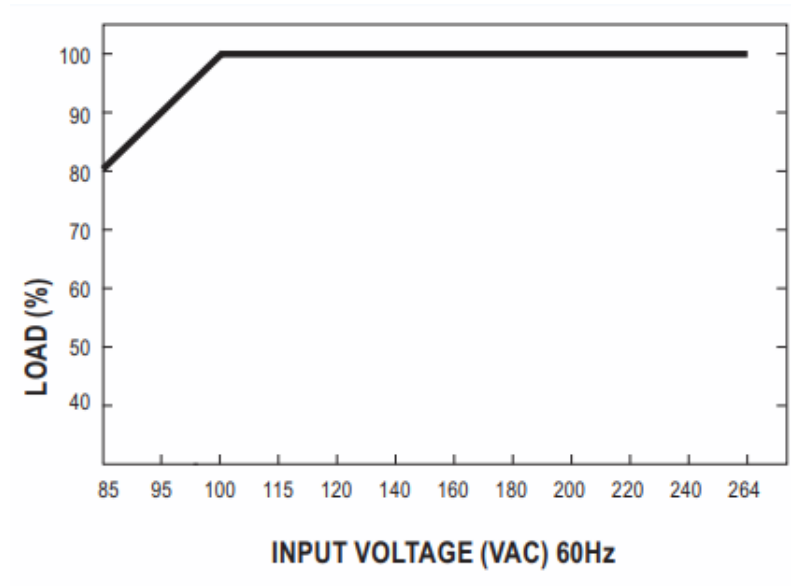

About Industrial Shields:

Direction: Camí del Grau, 25

Zip/Postal Code: 08272

City: Sant Fruitós de Bages (Barcelona)

Country: Spain

Telephone: (+34) 938 760 191 / (+34) 635 693 611

Mail: [industrialshields@industrialshields.com](mailto:industrialshields@industrialshields.com)